

Introducing Inverted SMT Thru Board Connector

Inverted SMT Thru Board Connector

KEY FEATURES

- Eliminates wire dress management issues with discreet wire leads around the surface of the LED pc board
- Accepts 2 thru 6 Position TE Mini CT Connector
- Low profile design
- Rounded corners to minimize shadowing
- Connector is positioned through cutout or notch in pc board
- Surface mount hold downs provide stability during mating and unmating
- High temperature material for reflow processing
- Flat top surface allows for vacuum pick up
- Tape and reel packaging for high speed SMT processing
- RoHS compliant
- 2 Position Connector available February 2009
- 3,4,5 & 6 Position Connectors will be available April 2009

DESCRIPTIONS

The Inverted SMT Thru Board Connector provides a means to bring power to LED aluminum clad and FR4 boards from the underside of the pc board.

APPLICATIONS

LED lighting controls

Indoor and outdoor lighting fixtures

General LED illumination fixtures

Various non-lighting applications that require wire dress connections below the pc board

ELECTRICAL

Operating Voltage: 70VAC / 70VDC

Operating Current:

#24 AWG - 3A

#26 AWG - 2.5A

#28 AWG - 1.5A

MATERIALS

Housing : 94 V0 rated high temperature resistant thermoplastic

Contacts : Tin over nickel plated copper alloy

STANDARDS AND SPECS

108-2376 : Inverted SMT Thru Board Design Objectives

114-13245 : Inverted SMT Thru Board Application Specification

108-60025 : Mini CT Connector Product Specification

114-5245 : Mini CT Connector Application Specification

UL : UL 1977 File No. E28476

MECHANICAL

Operating Temperature : -40°C to +105°C

Inverted SMT Thru Board Connector

PRODUCT OFFERING

Connector P/N	POSN	"A" DIM	"B" DIM	"C" DIM	"D" DIM	Mini CT Cable Assy P/N
2106091-1	2	5.5 [.216]	9.11 [.359]	6.00 [.236]	4.10 [.161]	2058943-1
2106091-2	3	7.00 [.275]	10.61 [.418]	7.50 [.295]	4.85 [.191]	2058943-2
2106091-3	4	8.50 [.335]	12.11 [.477]	9.00 [.354]	5.60 [.220]	2058943-3
2106091-4	5	10.00 [.394]	13.61 [.536]	10.50 [.413]	6.35 [.250]	2058943-4
2106091-5	6	11.50 [.453]	15.11 [.595]	12.00 [.472]	7.10 [.280]	2058943-5

Even Position PCB Layout

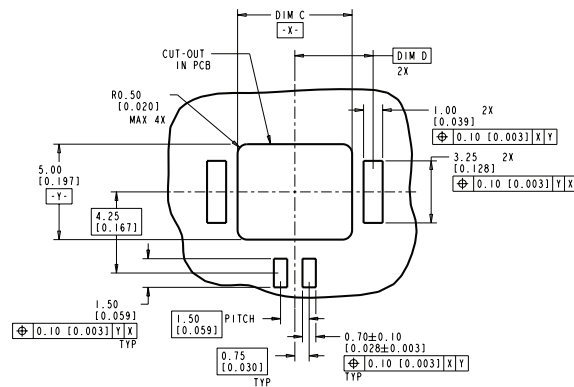

Odd Position PCB Layout

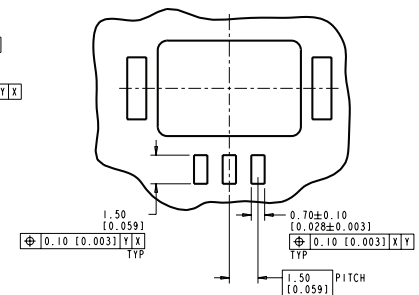

For more information on mating Mini CT products, please go to www.tycoelectronics.com.
keyword : Mini CT Crimp

SCALE 4:1

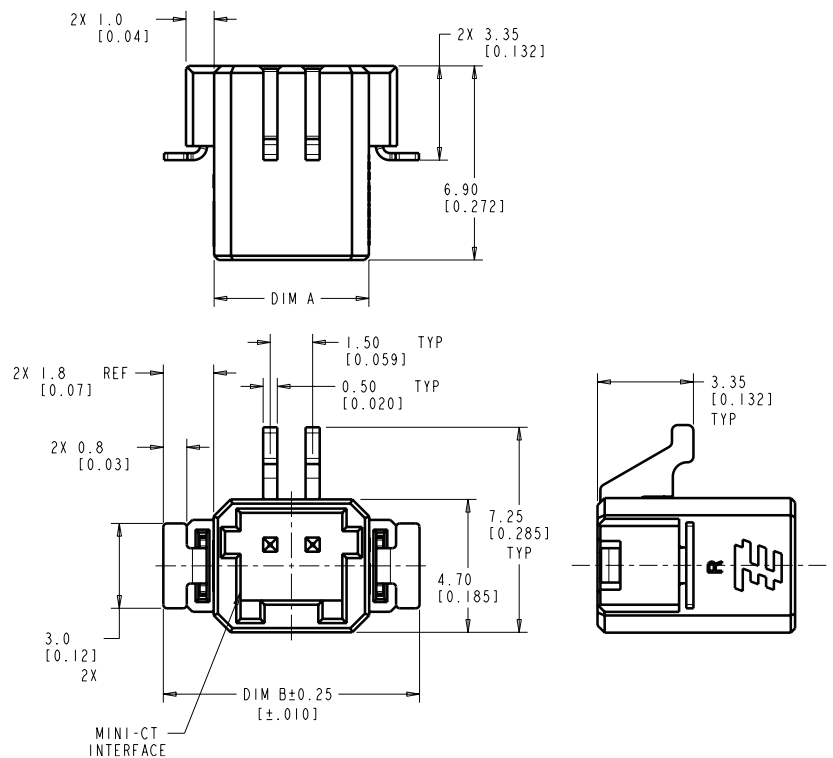
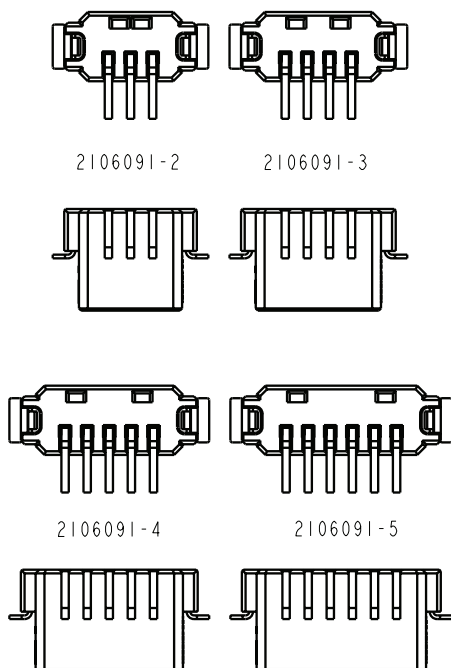

FOR MORE INFORMATION

www.tycoelectronics.com/lighting

Technical Support

Internet:	www.tycoelectronics.com/help
USA:	+1 (800) 522-6752
Canada:	+1 (905) 470-4425
Mexico & Central America:	+ 52(0) 55-1106-0814
South America:	+55 (0) 11-2103-6000
Germany:	+49 (0) 6251-133-1999
UK:	+ 44 (0) 8706-080208
France:	+33 (0) 1-3420-8686
Netherlands:	+31 (0) 73-6246-999
China:	+86 (0) 400-820-6015

Tyco Electronics Corporation
Harrisburg, PA

tycoelectronics.com

©2009 Tyco Electronics Corporation All Rights Reserved.

7-1773453-0 2.5M F/P 11/2009

TE (logo) and Tyco Electronics are trademarks of the Tyco Electronics group of companies and its licensors. Other products, logos, and Company names mentioned herein may be trademarks of their respective owners.

While Tyco Electronics has made every reasonable effort to ensure the accuracy of the information in this catalog, Tyco Electronics does not guarantee that it is error-free, nor does Tyco Electronics make any other representation, warranty or guarantee that the information is accurate, correct, reliable or current. Tyco Electronics reserves the right to make any adjustments to the information contained herein at any time without notice. Tyco Electronics expressly disclaims all implied warranties regarding the information contained herein, including, but not limited to, any implied warranties of merchantability or fitness for a particular purpose. The dimensions in this catalog are for reference purposes only and are subject to change without notice. Specifications are subject to change without notice. Consult Tyco Electronics for the latest dimensions and design specifications.



Tyco Electronics
Our commitment. Your advantage.