



# DIN RAIL ADAPTOR

## DESCRIPTION

TE Connectivity's DIN rail adaptor enables the easy installation of a structured cabling system inside industrial cabinets. The mounting adaptor is fully compatible with the AMP-TWIST and SL Series Jack family. The built-in grounding spring and ease of installation provide an ideal solution for industrial environments.

## APPLICATIONS

DIN rail mountings inside industrial cabinets

## KEY FEATURES

- Ease of installation
- Mount on DIN rail TH35
- Can be stacked sideways
- Width according to DIN 43880
- Built-in grounding spring
- IP20 protection
- Label area provided
- End cover set for additional protection
- Compatible with AMP-TWIST and SL Series jack family

## MATERIALS

- DIN Rail Adapter Kit - grey PA 30% glass filled

## STANDARDS & SPECIFICATIONS

- Instruction Sheet - 114-93017

# DIN Rail Adaptor

## PRODUCT DIMENSIONS

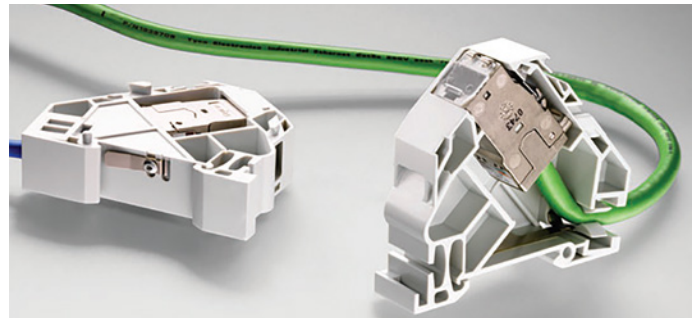
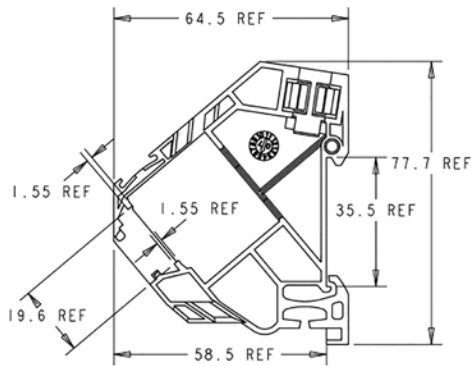

## PRODUCT OFFERINGS

- PN 1711897-1 - DIN Rail Adaptor
- PN 1711658-2 - DIN Rail Adaptor Covers (left and right)

## COMPATIBILITY

Product Description	TE Connectivity PN
SL Series 110 Connect, Cat. 5e, RJ45 Jack	1375191-X
SL Series 110 Connect, Cat. 5e, RJ45 Jack, with dust cover	1375190-X
SL Series 110 Connect, Cat. 6, RJ45 Jack	1375055-X
SL Series 110 Connect, Cat. 6, RJ45 Jack, with dust cover	1375187-X
AMP-TWIST 6S SL Jack, with dust cover	1711160-X
AMP-TWIST 6S SL Jack	1711342-X
AMP-TWIST 6AS SL Jack, with dust cover	1711592-X
AMP-TWIST 6AS SL Jack	1711716-X
Coupler, in-line, Cat. 5e, Black, shielded	2111122-x

## TE CONNECTIVITY BROADBAND NETWORK SOLUTIONS REGIONAL SALES HEADQUARTERS:

### North America

Greensboro, NC, USA  
Ph: +1-800-553-0938  
Fx: +1-717-986-7406

### Latin America

Buenos Aires, Argentina  
Ph: +54-11-4733-2200  
Fx: +54-11-4733-2282

### Europe

Kessel-Lo, Belgium  
Ph: +32-16-35-1321  
Fx: +32-16-35-2188

### Mid East & Africa

Cergy-Pontoise, France  
Ph: +33-1-3420-2122  
Fx: +33-1-3420-2268

### Asia

Hong Kong, China  
Ph: +852-2735-1628  
Fx: +852-2735-1625

### Pacific

Sydney, Australia  
Ph: +61-2-9554-2600  
Fx: +61-2-9554-2519

## te.com

TE Connectivity, TE connectivity (logo) and AMP-TWIST are trademarks. All other logos, products and/or company names referred to herein might be trademarks of their respective owners.

The information given herein, including drawings, illustrations and schematics which are intended for illustration purposes only, is believed to be reliable. However, TE Connectivity makes no warranties as to its accuracy or completeness and disclaims any liability in connection with its use. TE Connectivity's obligations shall only be as set forth in TE Connectivity's Standard Terms and Conditions of Sale for this product and in no case will TE Connectivity be liable for any incidental, indirect or consequential damages arising out of the sale, resale, use or misuse of the product. Users of TE Connectivity products should make their own evaluation to determine the suitability of each such product for the specific application.

© 2015 TE Connectivity Ltd. family of companies All Rights Reserved.

320932AE 06/15 Revision of 5-1773450-7 - 5m - MS/FP

## PRODUCT SHEET

### Contact us:

Please see above for the regional sales headquarters.

Or, alternatively, visit our website at:

[www.te.com](http://www.te.com)