

## 2-1761609-5 Product Details

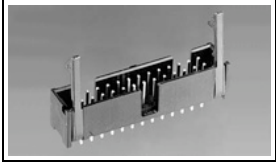

**2-1761609-5**

TE Internal Number: 2-1761609-5



### AMP-LATCH Pin and Pinless Headers

 Always EU RoHS/ELV Compliant (Statement of Compliance)

#### Product Highlights:

- Header
- Header Type = Pin Header
- AMP-LATCH Product Line
- Low Profile
- 14 Positions

### Documentation & Additional Information

#### Product Drawings:

- [HEADER ASSEMBLY, SHORT EJECT LATCH, RIGHT ANGLE, LOW...](#) (PDF, English)

#### Catalog Pages/Data Sheets:

- None Available

#### Product Specifications:

- [AMP-LATCH and IDC Header Connectors, .100 x .100 Inc...](#) (PDF, English)

#### Application Specifications:

- None Available

#### Instruction Sheets:

- None Available

#### CAD Files: (CAD Format & Compression Information)

- [2D Drawing](#) (DXF, Version F)
- [3D Model](#) (IGES, Version F)
- [3D Model](#) (STEP, Version F)

#### Additional Information:

- [Product Line Information](#)

#### Related Products:

- [Tooling](#)
- [Mating Products \(4\)](#)

### Product Features (Please use the Product Drawing for all design activity)

#### Product Type Features:

- Connector Type = Header
- Product Line = AMP-LATCH
- Profile = Low
- [PCB Mounting Orientation](#) = Right Angle
- [PCB Mount Retention](#) = Without
- [Mating Connector Lock](#) = With
- [Ejection Latches](#) = With
- Post Size (mm [in]) = 0.64 [.025]
- Shrouded = Yes

#### Termination Features:

- [Termination Post Length \(mm \[in\]\)](#) = 2.60 [0.102]
- Solder Tail Contact Plating = Tin over Nickel

#### Dimensions:

- [Shrouded] End Dimension (mm [in]) = 3.81 [0.150]

#### Body Features:

- Header Type = Pin Header

#### Contact Features:

- [Contact Plating, Mating Area, Material](#) = Gold Flash over Palladium Nickel
- Contact Shape = Square
- Contact Base Material = Phosphor Bronze

#### Housing Features:

- [Centerline, Matrix \(mm \[in\]\)](#) = 2.54 x 2.54 [.100 x .100]
- [Mating Alignment Type](#) = Center, Military
- [Housing Style](#) = 4-Sided
- Mating Alignment = With
- Housing Material = Thermoplastic - GF
- UL Flammability Rating = UL 94V-0
- Housing Color = Blue

#### Configuration Features:

- [Number of Positions](#) = 14

#### Industry Standards:

- [RoHS/ELV Compliance](#) = RoHS compliant, ELV compliant
- [Lead Free Solder Processes](#) = Wave solder capable to 240°C, Wave solder capable to 260°C, Wave solder capable to 265°C
- [RoHS/ELV Compliance History](#) = Always was RoHS compliant

#### Conditions for Usage:

- [Temperature Rating](#) = Standard

#### Other:

- Brand = AMP

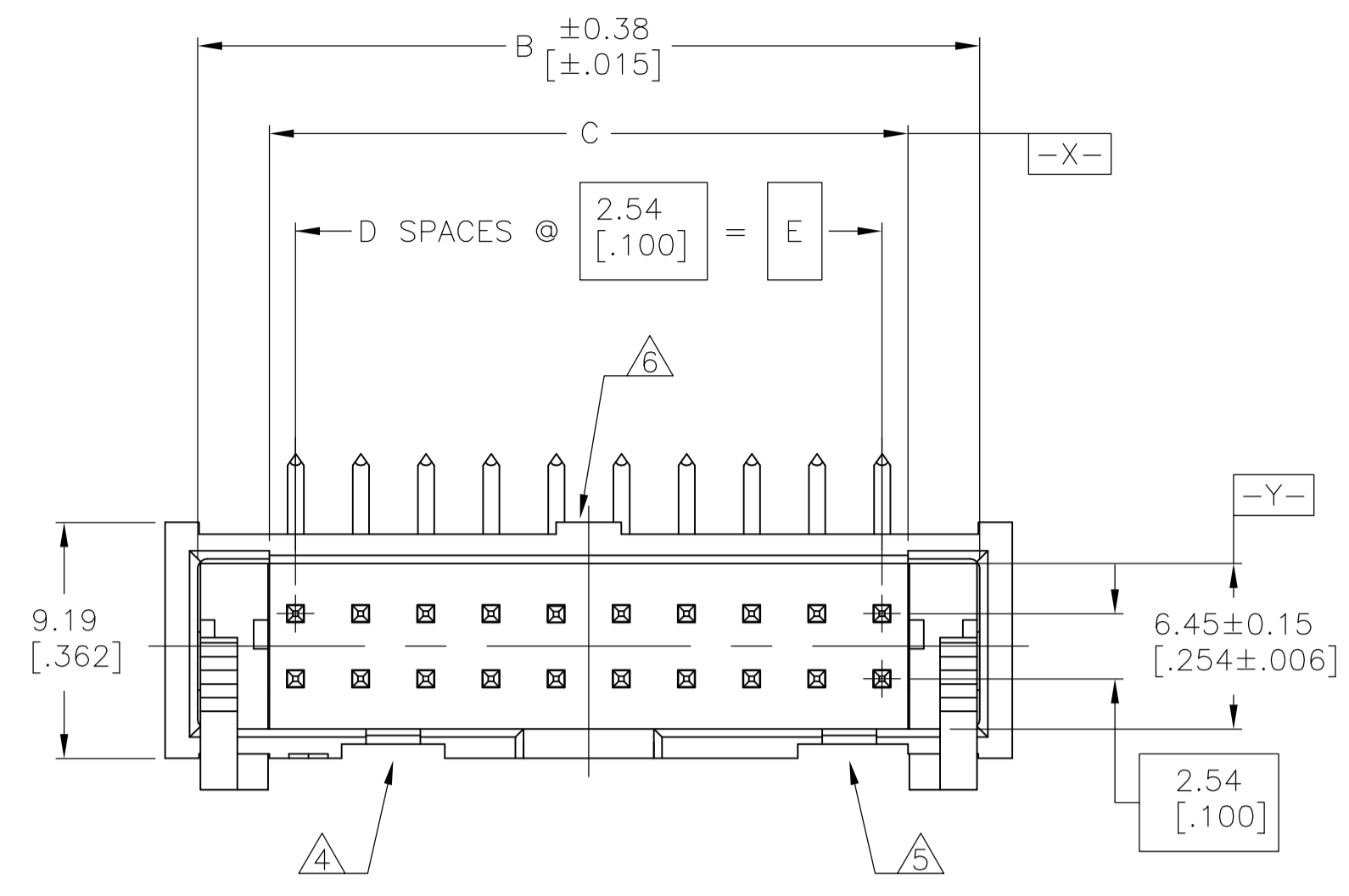

- △ HOUSING: PBT, UL94V-0, COLOR: (SEE TABLE).  
POSTS: PHOSPHOR BRONZE.  
LATCHES: ZINC ALLOY.
- △ POSTS: GOLD FLASH OVER PALLADIUM-NICKEL PLATE, 0.76µm[.000030] MIN TOTAL ON MATING AREA, 2.54µm[.000100] MIN TIN PLATE ON SOLDER-TAIL, ALL OVER 1.27µm[.000050] MIN NICKEL UNDERPLATE ON ENTIRE POST.  
OR  
0.76µm[.000030] MIN GOLD PLATE ON MATING AREA, 2.54µm[.000100] MIN TIN PLATE ON THE SOLDER-TAIL, 1.27µm[.000050] MIN NICKEL UNDERPLATE ON THE ENTIRE POST.  
LATCHES: BLACK NICKEL OVER COPPER.
- △ DATUMS S & T TO BE ESTABLISHED BY CUSTOMER.
- △ NO KEYING SLOT ON THIS END FOR 6, 10, 12, & 14 POSITION ASSEMBLIES.
- △ NO KEYING SLOT ON THIS END FOR 6 & 10 POSITION ASSEMBLIES.
- △ NO STANDOFF FOR 6, 10, 12, 14 & 16 POSITION ASSEMBLIES.
- △ ALTERNATE LOCATION/ORIENTATION FOR POSITION #1 INDICATOR.

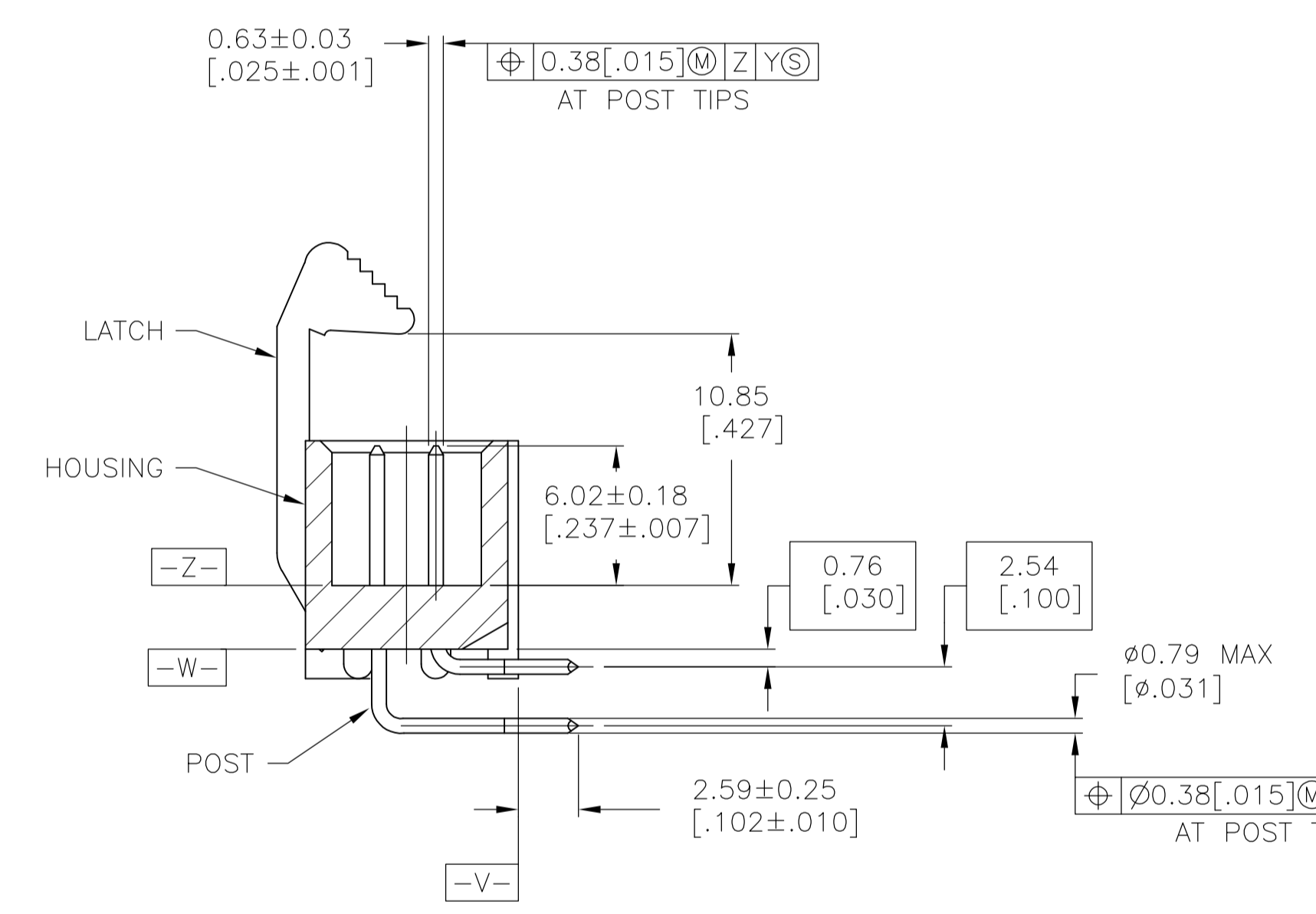
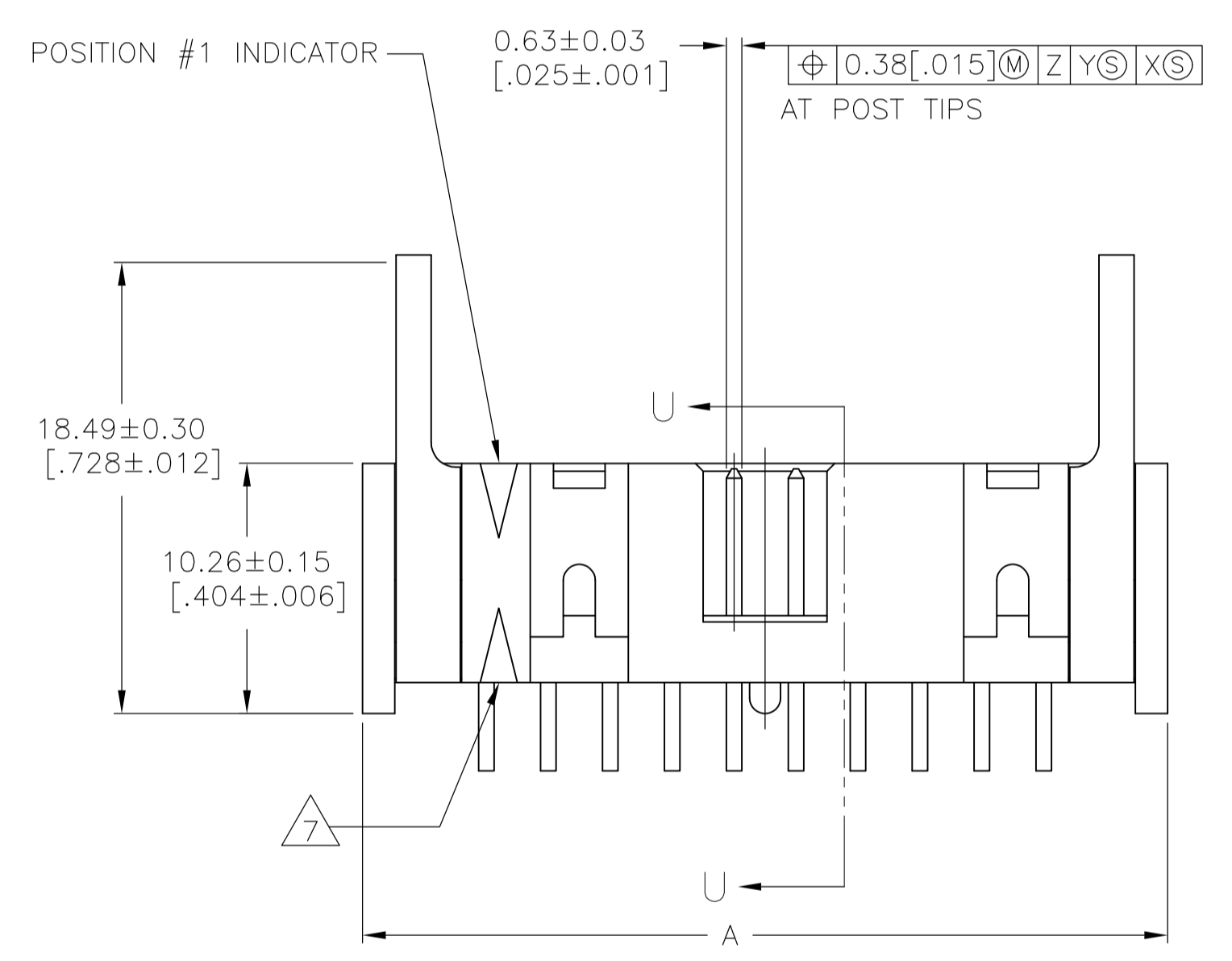

SECTION U-U

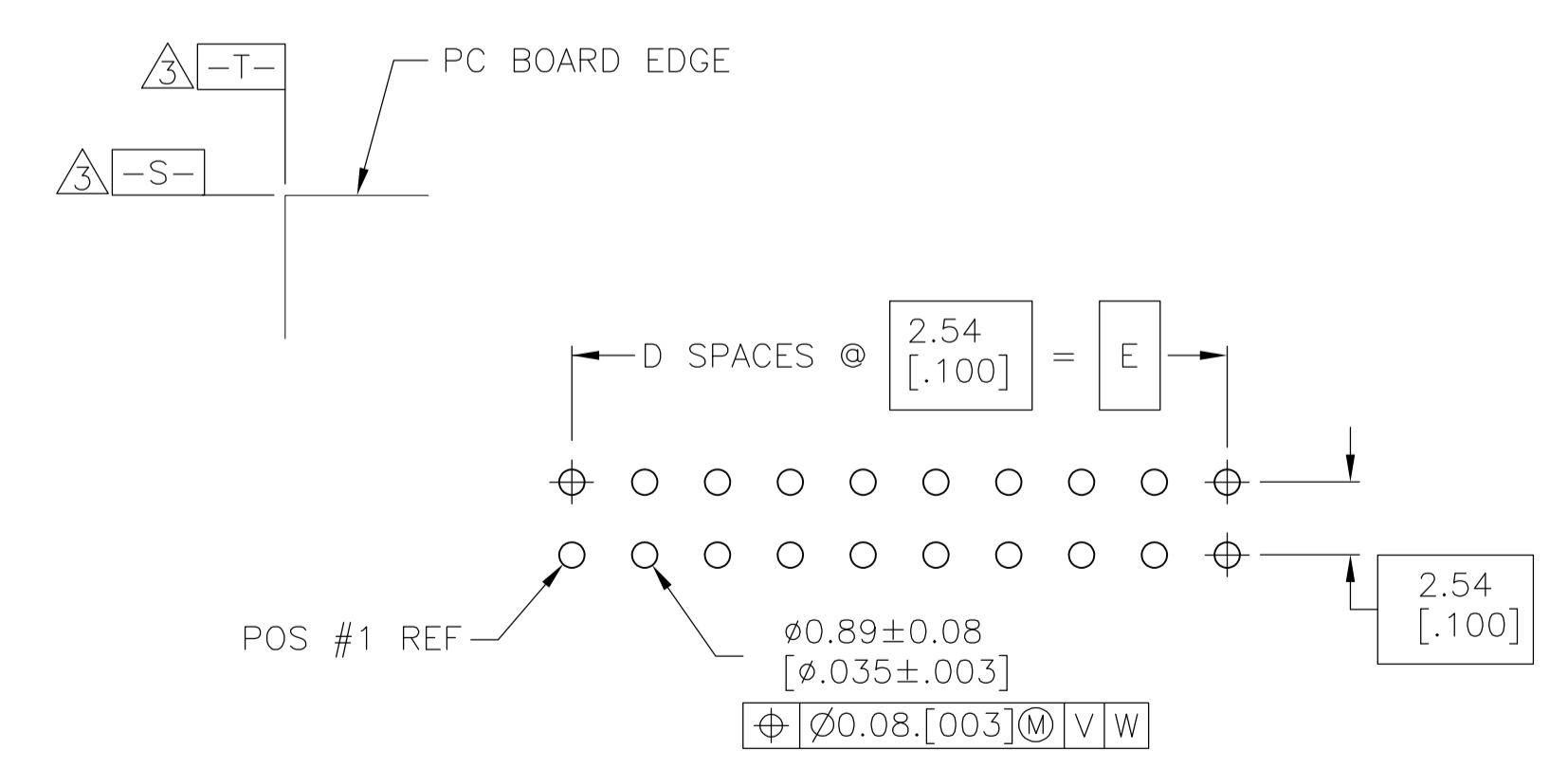

RECOMMENDED PC BOARD LAYOUT (VIEWED FROM CONNECTOR SIDE)

OBSOLETE		78.74 [3.100]	31	80.77 [3.180]	86.26 [3.396]	88.90 [3.500]	64	3-1761609-7
OBSOLETE		73.66 [2.900]	29	75.69 [2.980]	81.18 [3.196]	83.82 [3.300]	60	3-1761609-6
OBSOLETE		60.96 [2.400]	24	62.99 [2.480]	68.48 [2.696]	71.12 [2.800]	50	3-1761609-5
		48.26 [1.900]	19	50.29 [1.980]	55.78 [2.196]	58.42 [2.300]	40	3-1761609-3
		40.64 [1.600]	16	42.67 [1.680]	48.16 [1.896]	50.80 [2.000]	34	3-1761609-1
		35.56 [1.400]	14	37.59 [1.480]	43.08 [1.696]	45.72 [1.800]	30	3-1761609-0
	BLUE	30.48 [1.200]	12	32.51 [1.280]	38.00 [1.496]	40.64 [1.600]	26	2-1761609-9
		27.94 [1.100]	11	29.97 [1.180]	35.46 [1.396]	38.10 [1.500]	24	2-1761609-8
		22.86 [0.900]	9	24.89 [0.980]	30.38 [1.196]	33.02 [1.300]	20	2-1761609-7
		17.78 [0.700]	7	19.81 [0.780]	25.30 [0.996]	27.94 [1.100]	16	2-1761609-6
		15.24 [0.600]	6	17.27 [0.680]	22.76 [0.896]	25.40 [1.000]	14	2-1761609-5
		12.70 [0.500]	5	14.73 [0.580]	20.22 [0.796]	22.86 [0.900]	12	2-1761609-4
		10.16 [0.400]	4	12.19 [0.480]	17.68 [0.696]	20.32 [0.800]	10	2-1761609-3
OBSOLETE		5.08 [0.200]	2	7.11 [0.280]	12.60 [0.496]	15.24 [0.600]	6	2-1761609-1
		73.66 [2.900]	29	75.69 [2.980]	81.18 [3.196]	83.82 [3.300]	60	1-1761609-6
		60.96 [2.400]	24	62.99 [2.480]	68.48 [2.696]	71.12 [2.800]	50	1-1761609-5
		48.26 [1.900]	19	50.29 [1.980]	55.78 [2.196]	58.42 [2.300]	40	1-1761609-3
		40.64 [1.600]	16	42.67 [1.680]	48.16 [1.896]	50.80 [2.000]	34	1-1761609-1
	BLACK	30.48 [1.200]	12	32.51 [1.280]	38.00 [1.496]	40.64 [1.600]	26	1761609-9
		22.86 [0.900]	9	24.89 [0.980]	30.38 [1.196]	33.02 [1.300]	20	1761609-7
		17.78 [0.700]	7	19.81 [0.780]	25.30 [0.996]	27.94 [1.100]	16	1761609-6
		15.24 [0.600]	6	17.27 [0.680]	22.76 [0.896]	25.40 [1.000]	14	1761609-5
		10.16 [0.400]	4	12.19 [0.480]	17.68 [0.696]	20.32 [0.800]	10	1761609-3
	HOUSING COLOR	E	D	C	B	A	NO OF POS	PART NUMBER

THIS DRAWING IS A CONTROLLED DOCUMENT.

DIMENSIONS: mm [INCHES]	TOLERANCES UNLESS OTHERWISE SPECIFIED:	DIN B. CRISAMORE/DJI 30JUN05	APVD S. BOLASH 30JUN05	NAME M. WALMSLEY 30JUN05
0 PLC ± -	1 PLC ± -	2 PLC ± -	3 PLC ± 0.13[.005]	4 PLC ± -
ANGLES ± -				
MATERIAL	FINISH	WEIGHT	SIZE A1	CAGE CODE 00779
			DRAWING NO. 1761609	RESTRICTED TO
			SCALE 4:1	SHEET 1 OF 1
			CUSTOMER DRAWING	REV F1

STE TE Connectivity  
 HEADER ASSEMBLY, SHORT EJECT LATCH, RIGHT ANGLE, LOW PROFILE, IDC