

2198618-9 Product Details



2198618-9

TE Internal Number: 2198618-9

 Active

Cable Clamps

 Always EU RoHS/ELV Compliant (Statement of Compliance)

Product Highlights:

- Backshell/Cable Clamp
- Accessory Type = Cable Clamp
- Cable Clamp Type = Two-Piece RFI/EMI Shield
- 45° Cable Exit Angle
- Cable Insulation Diameter = 4.00 - 13.00 mm

Documentation & Additional Information

Product Drawings:

- [SHIELDED PLASTIC BACKSHELL 45 DEGREE ENTRY](#) (PDF, English)
- [LEAFLET ASSEMBLY INSTRUCTIONS ADK BACKSHELL](#) (PDF, English)

Catalog Pages/Data Sheets:

- None Available

Product Specifications:

- None Available

Application Specifications:

- None Available

Instruction Sheets:

- None Available

CAD Files:

- None Available

Additional Information:

- [Product Line Information](#)

Related Products:

- [Tooling](#)

Product Features (Please use the Product Drawing for all design activity)

Product Type Features:

- [Product Type](#) = Backshell/Cable Clamp
- Accessory Type = Cable Clamp
- [Cable Clamp Type](#) = Two-Piece RFI/EMI Shield
- [Shell Size](#) = 1
- [Screws and Retainer Clips](#) = With
- [Grommets](#) = With
- [Slide Latch](#) = Without
- Thread Size = 4-40

Electrical Characteristics:

- [Shielded](#) = Yes

Dimensions:

- [Cable Insulation Diameter \(mm \[in\]\)](#) = 4.00 - 13.00 [0.158 - 0.512]

Body Features:

- [Cable Exit Angle](#) = 45°
- Cable Clamp Material = ABS
- Shield Plating = Nickel

Configuration Features:

- Number of Positions = 9

Industry Standards:

- [RoHS/ELV Compliance](#) = RoHS compliant, ELV compliant
- [Lead Free Solder Processes](#) = Not relevant for lead free process
- RoHS/ELV Compliance History = Always was RoHS compliant

Packaging Features:

- [Packaging Method](#) = Bulk

Other:

- Brand = AMP

THIS DRAWING IS UNPUBLISHED. RELEASED FOR PUBLICATION 12, 2011.
 © COPYRIGHT 2011 By - ALL RIGHTS RESERVED.

LOC	DIST	REVISIONS			
P	LTR	DESCRIPTION	DATE	DWN	APVD
GP	00	REVISED PER ECO-13-000397	08NOV2012	CJV	CWR

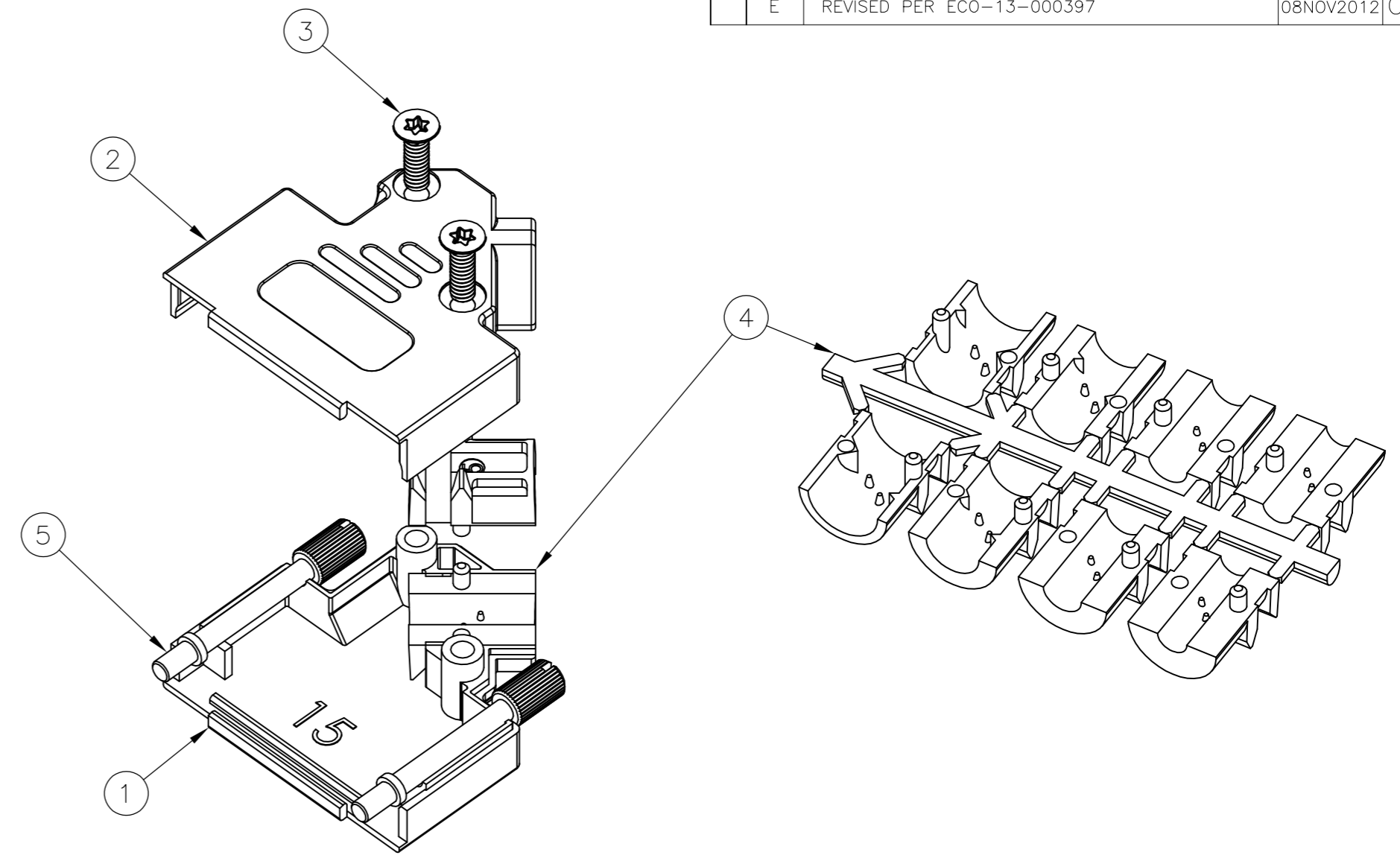
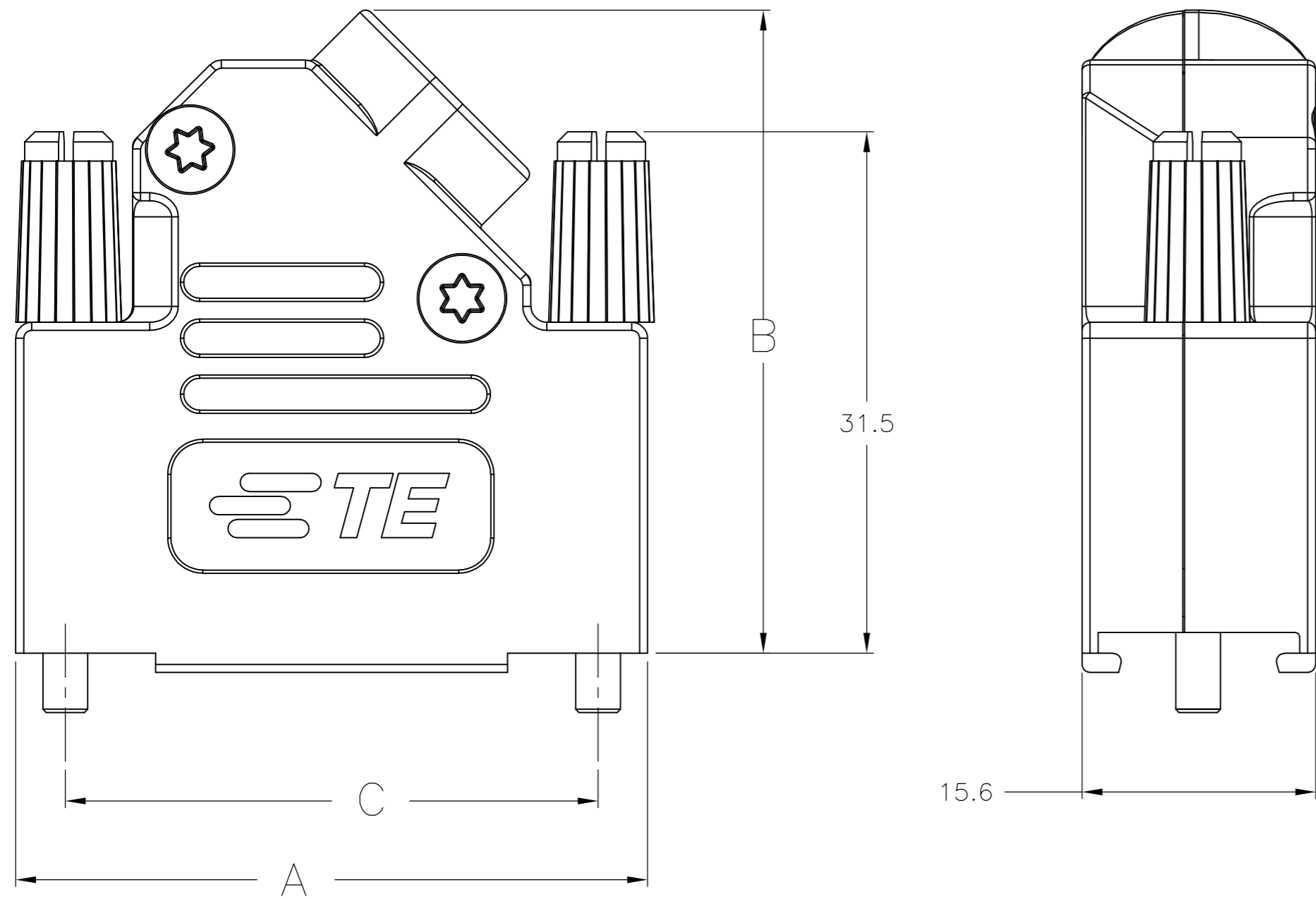

- 1. FOR ASSEMBLY DETAILS, REFER TO LEAFLET 2227518-1.
- 2. BULK PACKAGED BACKSHELL ASSEMBLIES: ITEMS 1 THRU 5, 100 TIMES QTY SHOWN IN TABLE IN 1 BAG FOR EACH ITEM. ALL BAGS IN 1 BOX WITH (1) 2227518-1 LEAFLET.
- 3. INDIVIDUALLY PACKAGED SHELL ASSEMBLIES: 1 BAG CONTAINS ALL COMPONENTS FOR 1 COMPLETE ASSEMBLY. 100 BAGS PER BOX, (1) 2227518-1 LEAFLET PER BOX.
- 4. TERMINATES 4.0-13.0 CABLE DIAMETERS.
- 5. 15 POSITION SHOWN.

- 6. TRIVALENT CHROMIUM CHROMATE COATING OVER ZINC PLATING.
- 7. JACKSCREW QUANTITY:
 9 WAY ASSEMBLY: 1 JACKSCREW
 15 WAY ASSEMBLY: 2 JACKSCREWS
 25 WAY ASSEMBLY: 2 JACKSCREWS
 37 WAY ASSEMBLY: 2 JACKSCREWS.
- 8. OPTIONAL CABLE CRIMP KIT AVAILABLE FOR 6.0-9.5 DIAMETER CABLE. SEE 1478764.

5	JACKSCREW ASSEMBLY, 4-40	POLYAMIDE, UL94 V2 KNOB	BLACK	7
		CARBON STEEL SHAFT	6	
4	STRAIN RELIEF SET	POLYCARBONATE UL94 V0	BLACK	1
3	SELF TAPPING FIXING SCREW	CARBON STEEL	6	2
2	TOP BACKSHELL	ABS UL94 V0	NICKEL	1
1	BOTTOM BACKSHELL	ABS UL94 V0	NICKEL	1
ITEM	DESCRIPTION	MATERIAL	FINISH	QTY

3	63.5	40.2	69.5	TORX	4-40 UNC	4	37 WAY	5-2198618-4
3	47.0	40.2	53.0	TORX	4-40 UNC	3	25 WAY	5-2198618-3
3	33.3	40.2	39.3	TORX	4-40 UNC	2	15 WAY	5-2198618-2
3	25.0	36.2	31.0	TORX	4-40 UNC	1	9 WAY	5-2198618-1
2	63.5	40.2	69.5	TORX	4-40 UNC	4	37 WAY	3-2198618-7
2	47.0	40.2	53.0	TORX	4-40 UNC	3	25 WAY	2-2198618-5
2	33.3	40.2	39.3	TORX	4-40 UNC	2	15 WAY	1-2198618-5
2	25.0	36.2	31.0	TORX	4-40 UNC	1	9 WAY	2198618-9
PACKAGING	C	B	A	SELF TAPPING FIXING SCREW TYPE	JACKSCREW THREAD	SHELL SIZE	POSITION	PART NUMBER

THIS DRAWING IS A CONTROLLED DOCUMENT. DIMENSIONING AND TOLERANCING PER ASME Y14.5M-2009

DWN: C. VALENTINE 09DEC2011
 CHK: C. ROHDE 08DEC2011
 APVD: C. ROHDE 08DEC2011

TE Connectivity
 SHIELDED PLASTIC BACKSHELL
 45 DEGREE ENTRY

SIZE: A2 CAGE CODE: 00779 DRAWING NO: C=2198618
 SCALE: 1:1 SHEET: 1 OF 1

TOLERANCES UNLESS OTHERWISE SPECIFIED:
 0 PLC ± 0.5
 1 PLC ± 0.5
 2 PLC ± 0.5
 3 PLC ± 0.5
 4 PLC ± 0.5
 ANGLES ± 0.5°

MATERIAL: SEE TABLE FINISH: SEE TABLE

CUSTOMER DRAWING