

THIS DRAWING IS UNPUBLISHED. RELEASED FOR PUBLICATION 20
 © COPYRIGHT 20 BY - ALL RIGHTS RESERVED.

LOC		DIST		REVISIONS			
P	LTR	DESCRIPTION	DATE	DWN	APVD		
5		ADD 108/114, PRELIM NOTE	09APR2013	CG	CG		
6		UPDATE VIEWS, 1.75 TO 2.10 SHT1B4	23MAY2013	CG	CG		
7		ADD SOLDERMASK, UPDATE DIM B	30MAY2013	CG	CG		
8		MATING PCB PAD LENGTH 2.45 TO 3.15	25JUL2013	CG	CG		

1.71 DISTANCE FROM COG TO CENTER OF PICK UP ZONE

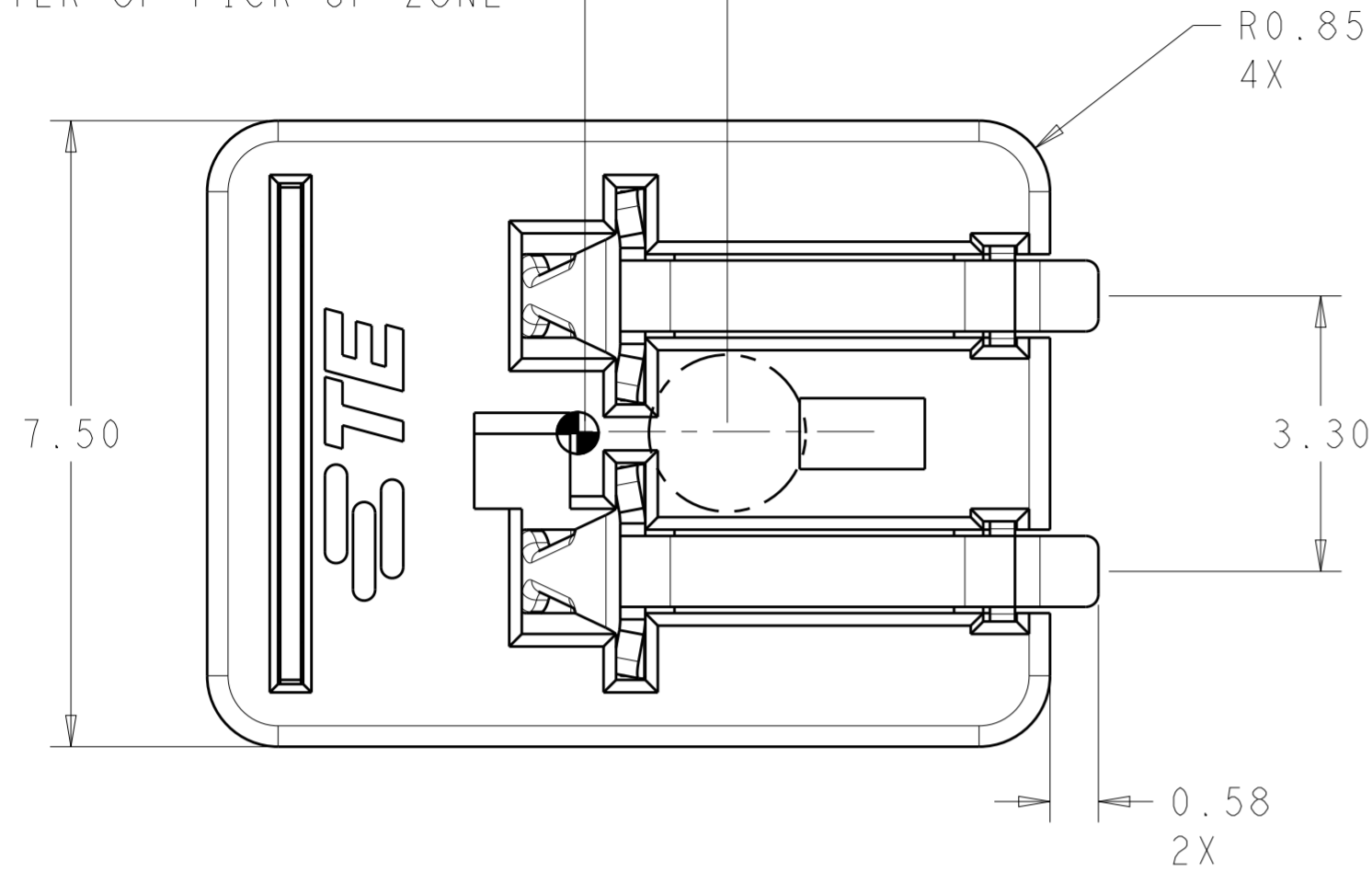

- 1 MATERIALS AND FINISH:
 -HOUSING AND COVER: THERMOPLASTIC, COLOR: NATURAL
 -CONTACTS: COPPER ALLOY, FINISH: Sn OVER Ni
 -HOLD DOWN: COPPER ALLOY, FINISH: Sn OVER Ni
- 2. MUST COMPLY WITH DIRECTIVE 2002/95/EC (ROHS)
- 3. THIS PRODUCT HAS NOT COMPLETED VALIDATION TESTING.
- 4. PACKAGED IN TAPE AND REEL
- 5 PCB EDGE TO BE DETERMINED BY CUSTOMER APPLICATION
- 6 TO BE USED WITH 1.0±10% PCB THICKNESS
- 7 TO BE USED WITH 1.6±10% PCB THICKNESS
- 8 DIMENSION SHOWN IS RECOMMENDED SOLDER MASK OPENING

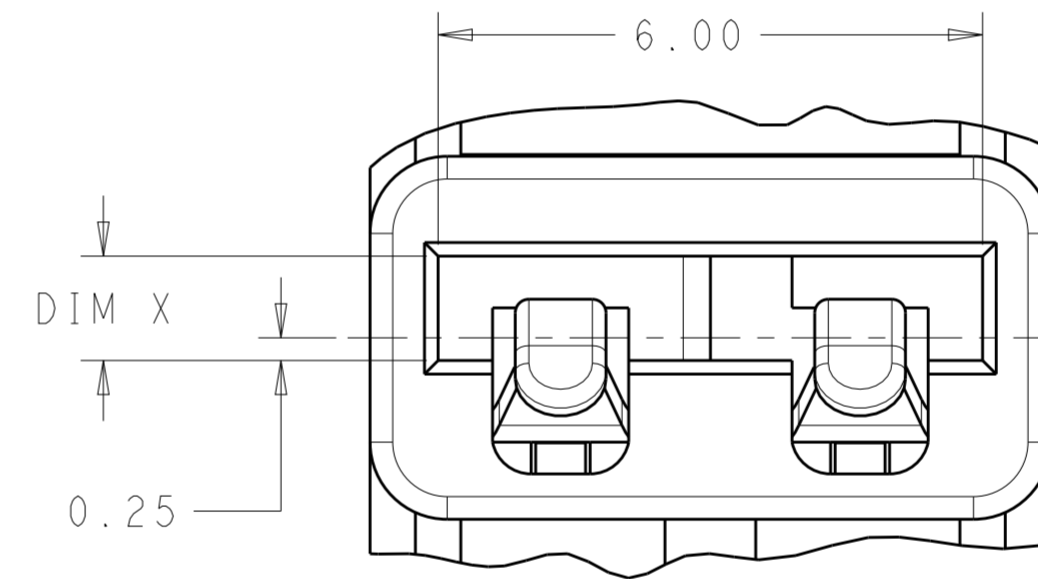

VIEW E
SCALE 12:1

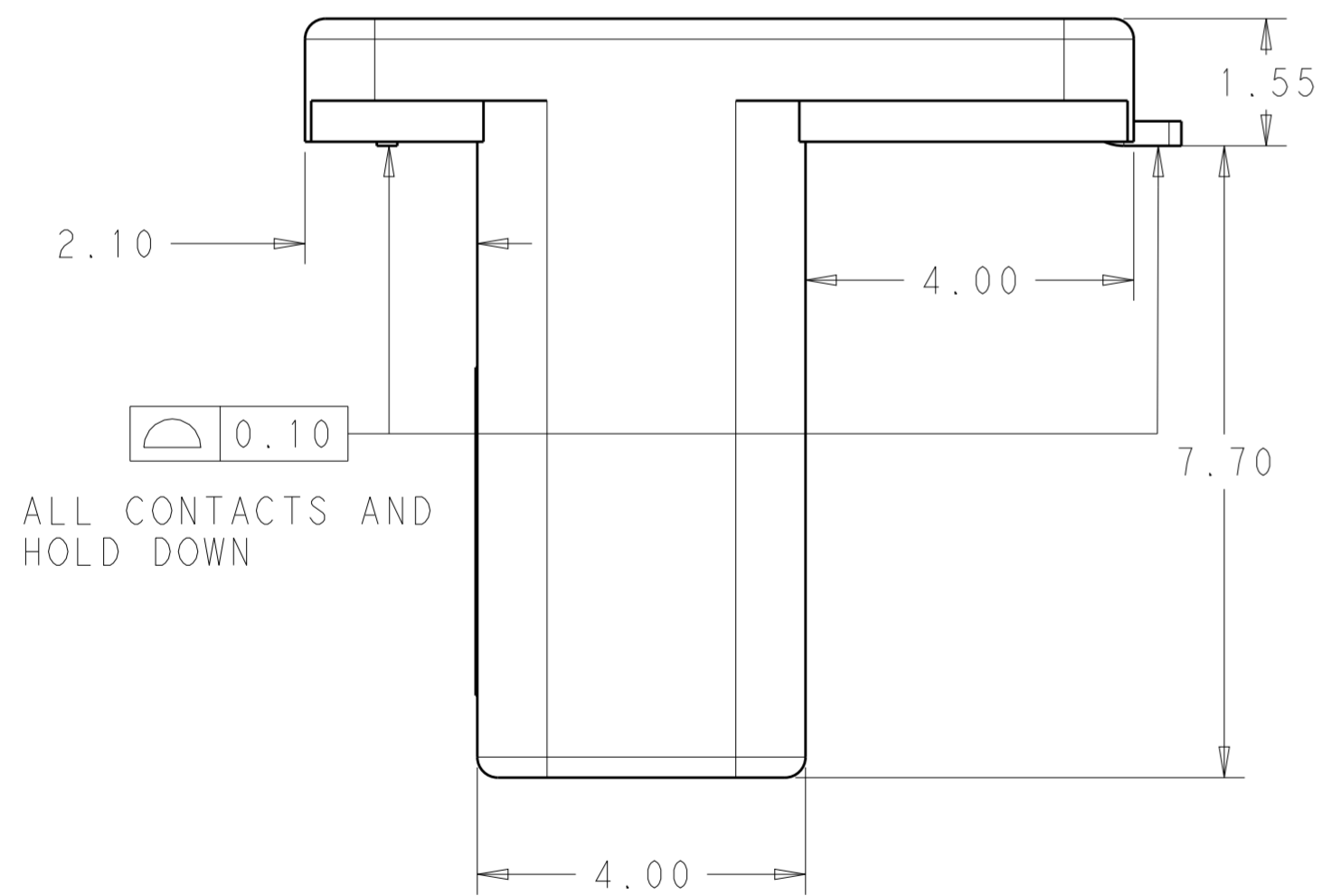

ALL CONTACTS AND HOLD DOWN

SEE VIEW E

2213188-1, -2

1.6	WITH COVER	1.44 - 1.75	1.81	2213188-4
1.0	WITH COVER	0.90 - 1.10	1.15	2213188-3
1.6	W/O COVER	1.44 - 1.75	1.81	2213188-2
1.0	W/O COVER	0.90 - 1.10	1.15	2213188-1
MARKING	COVER	DIM B	DIM X	PART NO.

THIS PRINT IS
PRELIMINARY
 UNQUALIFIED PRODUCT
 CONTACT PRODUCT ENGINEERING
 BEFORE USING THIS PRINT

DIMENSIONS:		TOLERANCES UNLESS OTHERWISE SPECIFIED:		DWN		CHK		APVD		NAME	
mm		0 PLC ±		C. DAILY 25OCT2012		C. GINGRICH 25OCT2012		-		-	
1 PLC ±0.2		2 PLC ±0.15		PRODUCT SPEC		108-32041		APPLICATION SPEC		114-32054	
3 PLC ±		4 PLC ±		WEIGHT		-		SIZE		A200779	
ANGLES ±2A°		FINISH		Customer Drawing		SCALE 7:1		SHEET 1 OF 4		REV 8	

STE TE Connectivity
PRELIMINARY
 ASSEMBLY
 CARD EDGE INVERTED THROUGH BOARD

THIS DRAWING IS UNPUBLISHED. RELEASED FOR PUBLICATION 20
 © COPYRIGHT 20 BY - ALL RIGHTS RESERVED.

LOC	DIST	REVISIONS					
		P	LTR	DESCRIPTION	DATE	DWN	APVD
-	-	-	-	SEE SHEET 1	-	-	-

R1.25

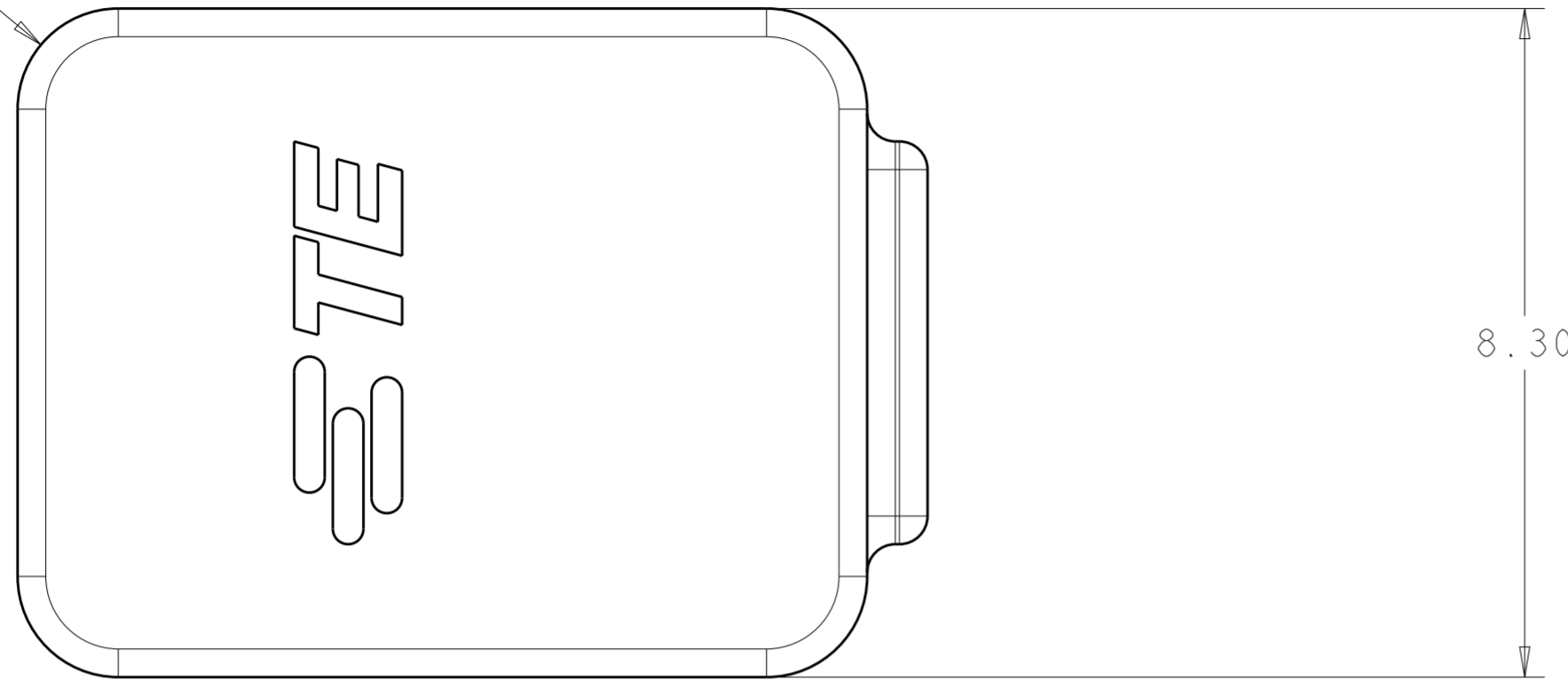

SCALE 12:1

2213188-3, -4

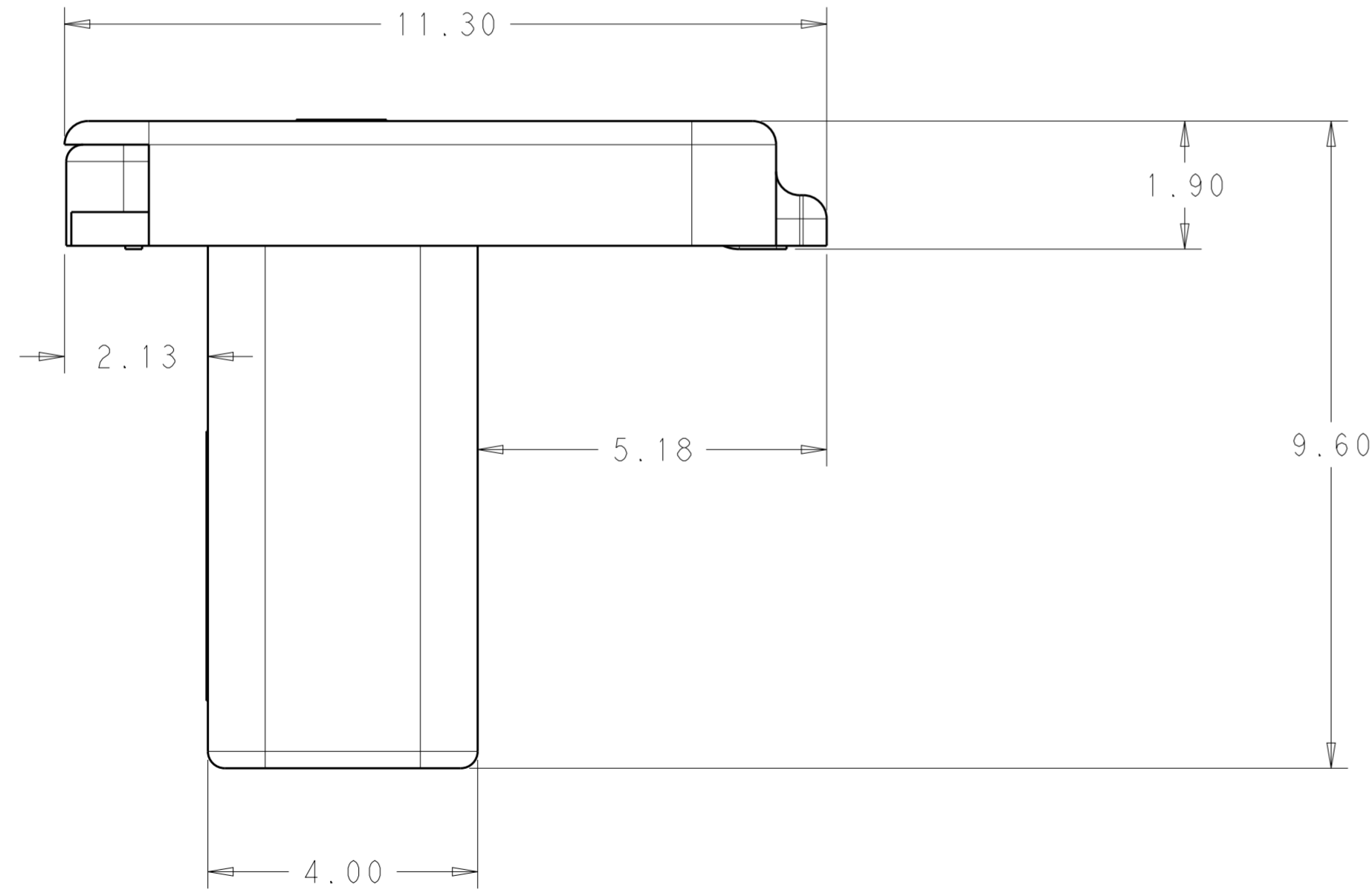

THIS PRINT IS
PRELIMINARY
 UNQUALIFIED PRODUCT
 CONTACT PRODUCT ENGINEERING
 BEFORE USING THIS PRINT

THIS DRAWING IS A CONTROLLED DOCUMENT.		DWN C. DAILY 25OCT2012	STC TE Connectivity	
DIMENSIONS: mm		CHK C. GINGRICH 25OCT2012		
TOLERANCES UNLESS OTHERWISE SPECIFIED:		APVD -	NAME ASSEMBLY, CARD EDGE INVERTED THROUGH BOARD	
0 PLC ± 1 PLC ±0.2 2 PLC ±0.15 3 PLC ± 4 PLC ±		PRODUCT SPEC 108-32041	SIZE A200779	
ANGLES ±2° FINISH		APPLICATION SPEC 114-32054	DRAWING NO C-2213188	
MATERIAL -		WEIGHT -	RESTRICTED TO -	
		Customer Drawing	SCALE 7:1	SHEET 2 OF 4 REV 8

THIS DRAWING IS UNPUBLISHED. RELEASED FOR PUBLICATION 20
 © COPYRIGHT 20 BY - ALL RIGHTS RESERVED.

LOC		DIST		REVISIONS			
P	LTR	DESCRIPTION	DATE	DWN	APVD		
-	-	SEE SHEET 1	-	-	-		

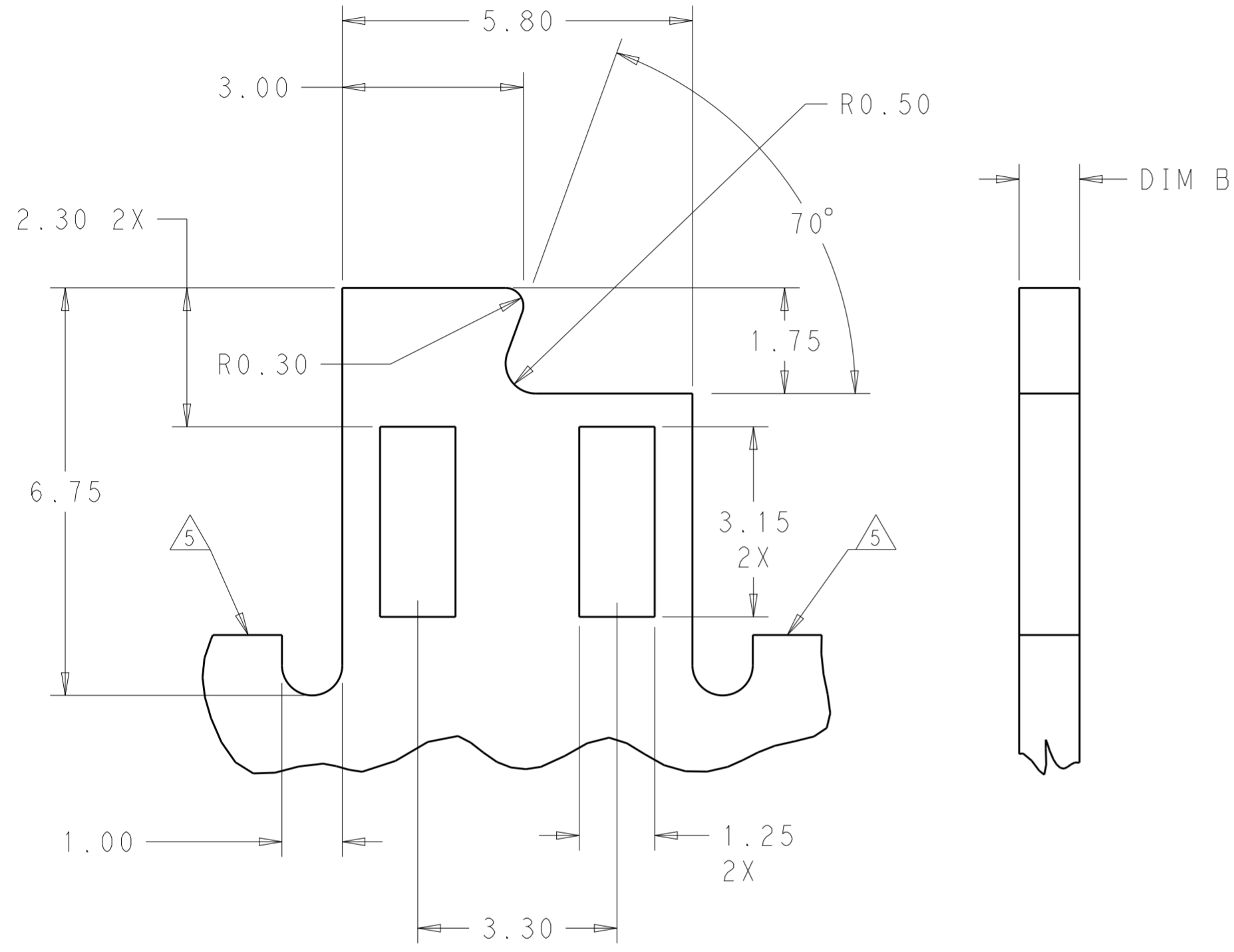

MATING PCB DETAILS
SCALE 12:1

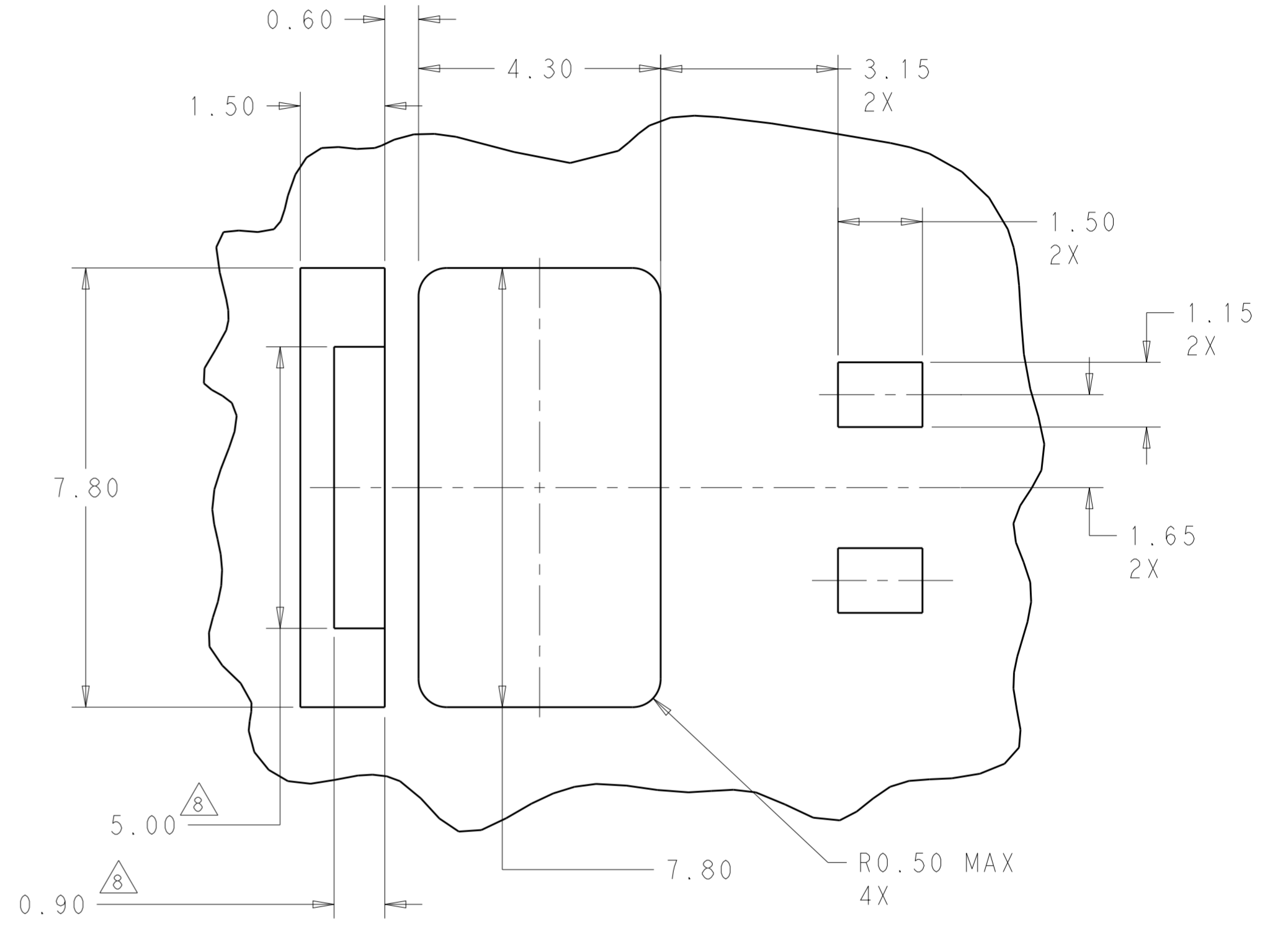

MOUNTING PCB LAYOUT
SCALE 12:1

THIS PRINT IS
PRELIMINARY
 UNQUALIFIED PRODUCT
 CONTACT PRODUCT ENGINEERING
 BEFORE USING THIS PRINT

THIS DRAWING IS A CONTROLLED DOCUMENT.		DWN C. DAILY 25OCT2012	TE Connectivity	
DIMENSIONS: mm		CHK C. GINGRICH 25OCT2012		
TOLERANCES UNLESS OTHERWISE SPECIFIED:		APVD -	NAME ASSEMBLY, CARD EDGE INVERTED THROUGH BOARD	
0 PLC ± 1 PLC ±0.2 2 PLC ±0.15 3 PLC ± 4 PLC ± ANGLES ±2A° FINISH		PRODUCT SPEC 108-32041	SIZE A200779	
MATERIAL -		APPLICATION SPEC 114-32054	DRAWING NO C-2213188	
		WEIGHT -	RESTRICTED TO -	
		Customer Drawing	SCALE 7:1 SHEET 3 OF 4 REV 8	

THIS DRAWING IS UNPUBLISHED. RELEASED FOR PUBLICATION 20
 © COPYRIGHT 20 BY - ALL RIGHTS RESERVED.

LOC		DIST		REVISIONS			
P	LTR	DESCRIPTION	DATE	DWN	APVD		
-	-	SEE SHEET 1	-	-	-		

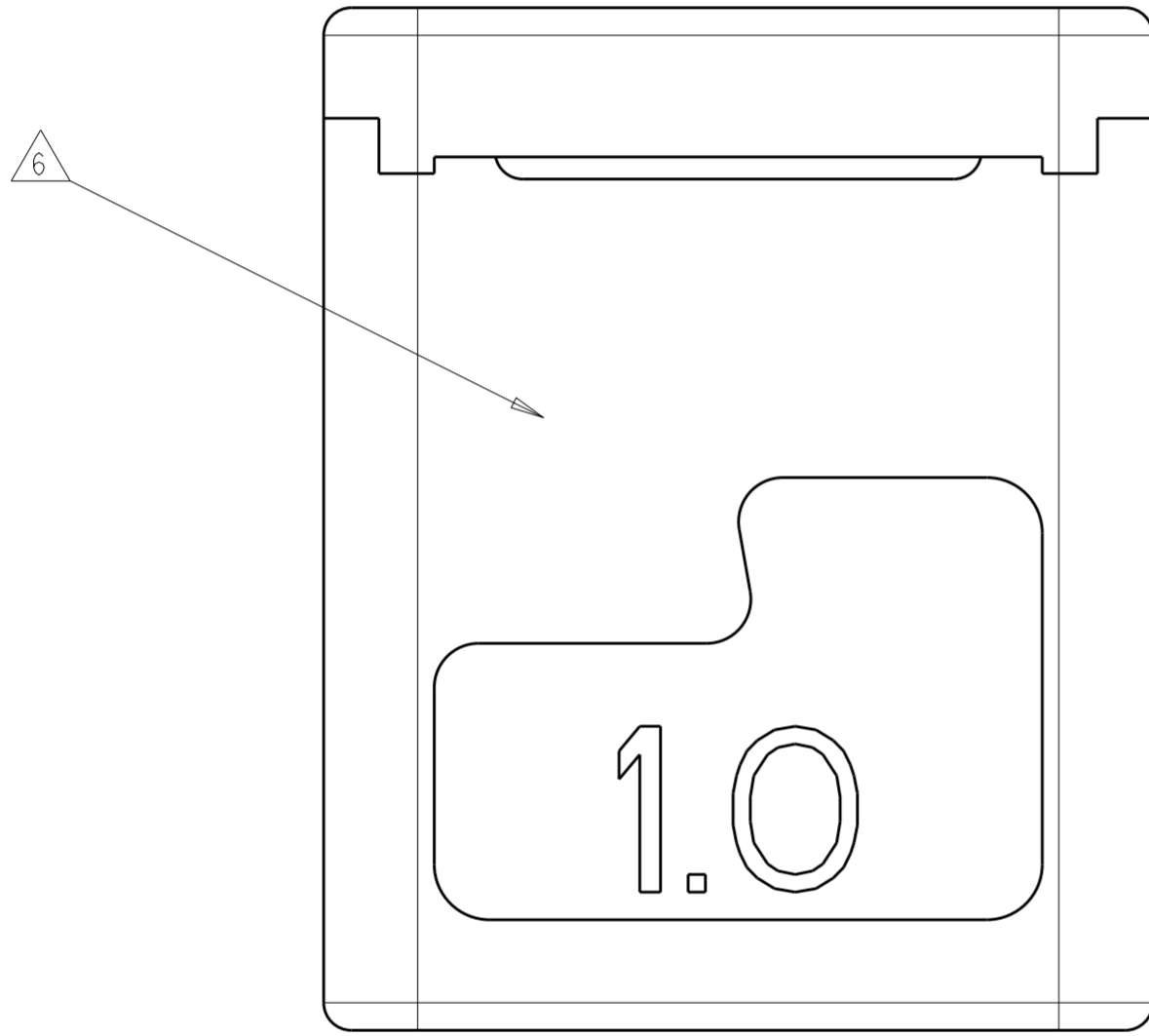

2213188-1, -3
SCALE 15:1

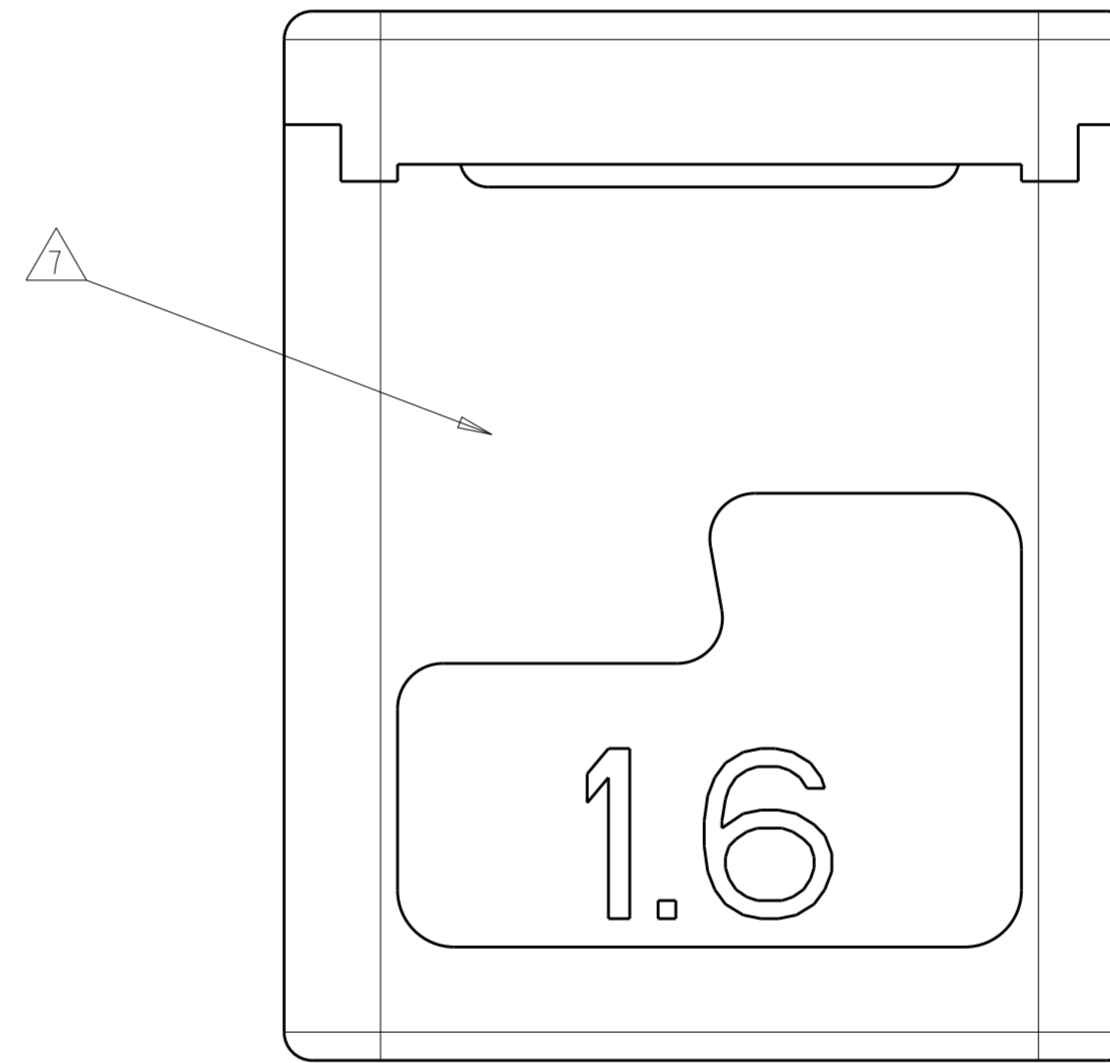

2213188-2, -4
SCALE 15:1

THIS PRINT IS
PRELIMINARY
 UNQUALIFIED PRODUCT
 CONTACT PRODUCT ENGINEERING
 BEFORE USING THIS PRINT

THIS DRAWING IS A CONTROLLED DOCUMENT.		DWN C. DAILY 25OCT2012	STE TE Connectivity	
DIMENSIONS: mm		CHK C. GINGRICH 25OCT2012		
TOLERANCES UNLESS OTHERWISE SPECIFIED: 0 PLC ± 1 PLC ±0.2 2 PLC ±0.15 3 PLC ± 4 PLC ± ANGLES ±2° FINISH		APVD -	NAME ASSEMBLY, CARD EDGE INVERTED THROUGH BOARD	
MATERIAL -		PRODUCT SPEC 108-32041	SIZE A200779	CAGE CODE C-2213188
		APPLICATION SPEC 114-32054	DRAWING NO C-2213188	RESTRICTED TO -
		WEIGHT -	SCALE 7:1 SHEET 4 OF 4 REV 8	
		Customer Drawing		