



The product described in this document has not been fully tested to ensure conformance to the requirements outlined below. Therefore, TE Connectivity (TE) makes no representation or warranty, express or implied, that the product will comply with these requirements. Further, TE may change these requirements based on the results of additional testing and evaluation. Contact TE Engineering for further details.

## CoolSplice Connector

### 1. SCOPE

#### 1.1. Content

This specification covers performances, tests and quality requirements of the: "CoolSplice Connector" with part number x-2213600-y & 2213800-y, applied according application specification 114-133061.

#### 1.2. Qualification

When tests are performed on the CoolSplice Connector, procedures specified in Figure 1 shall be used. All inspections shall be performed using the applicable inspection plan and product drawing.

#### 1.3. Qualification Test Results

Successful qualification testing on the CoolSplice Connector is complete for 2213600-x and 2213800-x. The Qualification Test Report number can be found below, in TE documents.

### 2. APPLICABLE DOCUMENTS AND FORMS

The following documents and forms constitute a part of this specification to the extent specified herein. Unless otherwise indicated, the latest edition of the document applies.

#### 2.1. TE Documents

- ◆ [2213600](#): Customer drawing CoolSplice Large Gauge
- ◆ [2213800](#): Customer drawing CoolSplice New Standard
- ◆ [108-133061-1](#): Product Specification CoolSplice, Japanese translation
- ◆ [114-133061](#): Application Specification
- ◆ [107-133061](#): Packaging Specification
- ◆ [501-19232](#): Qualification Test Report: 2213600-y CoolSplice Large Gauge
- ◆ [501-19234](#): Qualification Test Report: 2213800-y CoolSplice New Standard
- ◆ [501-19244](#): CoolSplice (Location Change Powergel) Qualification Tests
- ◆ [502-153194](#): CoolSplice LW Extension - Static Heat Sequence

#### 2.2. Industry Documents

- ◆ IEC 60998-2-3, applicable for 2213600-y, 2213800-y, 2213917-y, 2213918-y & 2213920-y
- ◆ UL 486C Listed, applicable to 2213600-y & 2213920-y
- ◆ UL 1977 Recognized, applicable to 2213800-y CoolSplice New Standard
- ◆ UL 2459 Listed, applicable to 2213800-y, 2213917-y & 2213918-y

#### 2.3. Reference Document

- ◆ [109-197](#) Test Specification (TE Test Specification vs EIA and IEC Test Methods)

### 3. REQUIREMENTS

#### 3.1. Design and Construction

Product shall be of the design, construction, materials and physical dimensions specified on the applicable product drawing.

#### 3.2. Ratings

- ◆ 2213600-1 & -4:  
Suitable for 12 AWG/14 AWG ( $\approx 4 \text{ mm}^2/2.5 \text{ mm}^2$ ) to 14 AWG/16 AWG ( $\approx 2.5 \text{ mm}^2/1.5 \text{ mm}^2$ ).  
Wire according UL1015, solid and stranded (maximum of 19 strands).
- ◆ 2213600-2 & -5:  
Suitable for 12 AWG/14 AWG ( $\approx 4 \text{ mm}^2/2.5 \text{ mm}^2$ ) to 16 AWG/18 AWG ( $\approx 1.5 \text{ mm}^2/0.75 \text{ mm}^2$ )  
Wire according UL1015, solid and stranded (maximum of 19 strands).
- ◆ 2213600-3 & -6:  
Suitable for 14 AWG/16 AWG ( $\approx 2.5 \text{ mm}^2/1.5 \text{ mm}^2$ ) to 16 AWG/18 AWG ( $\approx 1.5 \text{ mm}^2/0.75 \text{ mm}^2$ )  
Wire according UL1015, solid and stranded (maximum of 19 strands).
- ◆ 2213600-7 & -9:  
Suitable for 12 AWG/14 AWG ( $\approx 4 \text{ mm}^2/2.5 \text{ mm}^2$ ) to 12 AWG/14 AWG ( $\approx 4 \text{ mm}^2/2.5 \text{ mm}^2$ )  
Wire according UL1015, solid and stranded (maximum of 19 strands).
- ◆ 2213600-8 & 1-2213600-0:  
Suitable for 16 AWG/18 AWG ( $\approx 1.5 \text{ mm}^2/0.75 \text{ mm}^2$ ) to 16 AWG/18 AWG ( $\approx 1.5 \text{ mm}^2/0.75 \text{ mm}^2$ )  
Wire according UL1015, solid and stranded (maximum of 19 strands).
- ◆ 2213800-1 & -2:  
Suitable for 18 AWG ( $\approx 0.75 \text{ mm}^2$ ).  
Wire according UL1007, UL 1015 or equivalent, solid and stranded (maximum of 19 strands).
- ◆ 2213800-3 & -4:  
Suitable for 20 AWG ( $\approx 0.5 \text{ mm}^2$ ) & 22 AWG ( $\approx 0.34 \text{ mm}^2$ ).  
Wire according UL1007, UL 1015 or equivalent, solid and stranded (maximum of 18 strands for 20 AWG and 7 strands for 22 AWG).

Part number	Voltage	Current	Temperature	IP rating
x-2213600-y	600 Volt	Pending on the smallest wire inserted: 12 AWG: 20 A 14 AWG: 15 A 16 AWG: 15 A 18 AWG: 10 A	-40 °C to 105 °C. Ambient temperature max 75 °C.	IP20 for -4 -5, -6, -9 & 1--0. IPx5, IPx7 & IPx8 Valid for -1 -2, -3, -7 & -8.
2213800-y	600 Volt (450 Volt IEC 60998-2-3) (600 V dc / 400 V ac UL2459)	18 AWG: 6.5 A (5 A, IEC 60998-2-3) (6.2 A, UL 2459) 20 AWG: 6.5 A (5 A, IEC 60998-2-3) (5 A, UL 2459) 22 AWG: 5 A (5 A, IEC 60998-2-3) (3.5 A, UL 2459)	-40 °C to 105 °C. Ambient temperature max 75 °C.	IP20 for -1 & -3. IPx5, IPx7 & IPx8 Valid for -2 & -4.

### 3.3. ENVIRONMENTAL

Product shall be RoSH & REACH compliant.

### 3.4. Test Requirements and Procedures Summary

Unless otherwise specified, all tests shall be performed at ambient environmental conditions.

TEST DESCRIPTION	REQUIREMENT	PROCEDURE
Initial examination of product	Meets requirements of product drawing.	Visual, dimensional and functional inspection, according to the Quality Inspection Plan.
Visual Examination of Product	The product shall not have visible marks of damage, break, or defect before and after the execution of the tests.	EIA-364-18B

#### ELECTRICAL

Contact resistance	Initial resistance maximum 25 mΩ initial. Maximum resistance after testing not exceeding 100 mΩ. Open voltage: 20 mV maximum Current 100 mA maximum	EIA-364-23, Option 1
Insulation resistance	500 MΩ minimum	IEC 60512-3-1 Test 3a
Temperature rise	$\Delta T < 30\text{ }^{\circ}\text{C}$  Measure temperature rise at 1 A and increase current in steps of 1 A. After a stabilization period of 1 hour and up to fail	EIA 364-70, Method 2
Voltage proof (between adjacent contacts and contacts & housing)	3400 V AC Duration: 60 s	IEC 60512-4-1, Test 4a UL2459 / UL 486C

#### MECHANICAL

Cable retention force (axial)	12 AWG minimum 155 N 14 AWG minimum 120 N 16 AWG minimum 70 N 18 AWG minimum 50 N 20 AWG minimum 50 N 22 AWG minimum 50 N No visual damage.	EIA 364-13 method A
Cable retention force (90°)	12 AWG minimum 155 N 14 AWG minimum 120 N 16 AWG minimum 70 N 18 AWG minimum 50 N 20 AWG minimum 50 N 22 AWG minimum 50 N	EIA 364-13 method A.

	<p>Cable pulled 90° on insertion direction (towards the button). No visual damage.</p>	
Vibration Test	<p>No visual damage. Discontinuity &lt;1 µsec Duration: 4 hours for each axis (x, y, z). Frequency: 10-200-10 Hz Peak to peak amplitude 1,0 mm Speed: 1 octave/min. Acceleration: 5 g</p>	IEC 60068-2-6
Impact	<p>No visual damage. Maximum resistance after testing not exceeding 100 mΩ. Open One time dropped from 5 meters on concrete floor</p>	
Separation force	<p>Minimum of 50 N Pulling two mated CoolSplices apart by means of pulling from wires (see figure 1) Only for 2213600-x</p>	

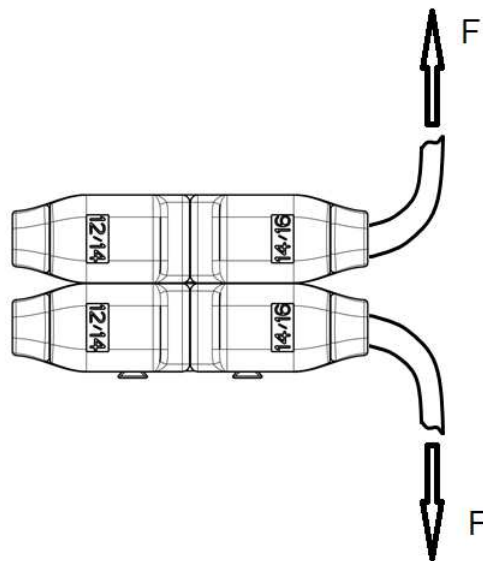

Figure 1

**ENVIRONMENTAL**

IPX5	Passing	IEC 60529
IPX8 (this includes IPx7: 30 minutes submerged in 1 meter depth)	2 hours submerged in 1 meter depth	IEC 60529
Cold	Temperature: -40 °C Duration: 2h	IEC 60068-2-1
Dry heat	Temperature: 100 °C Duration: 2h	IEC 60068-2-2
Damp heat	Temperature: 40 ± 2 °C Relative humidity: 93 3/-2 % Duration: 4 days	IEC 60068-2-3
Thermal shock	T <sub>a</sub> = -40 °C; T <sub>b</sub> = 100 °C 100 cycles, 30 min/30 min	IEC 60068-2-14, Test Na
Thermal cycling with current load cyclic	T <sub>a</sub> = 20 °C (t = 30 min. including transition) T <sub>b</sub> = 50 °C (t = 30 min. including transition) Number of cycles: 192 Temperature transition rate: 5 °C/min. Total cycle duration: 1 h Current: 1,5 A for 45 min/0 A for 15 min.	IEC 60068-2-14, test Nb  IEC 60512-9-5 Test 9e

**Figure 1.**

**NOTE**

Shall meet visual requirements, show no physical damage, and meet requirements of additional tests as specified in the Product Qualification and Requalification Test Sequence shown in Figure 2.

## 3.5. Product Qualification and Requalification Test Sequence

TEST OR EXAMINATION	TEST GROUP (a)				
	A	B	C 2213600-x	C 2213800-x	D
	TEST SEQUENCE (b)				
Visual examination of product	1, 13	1, 17	1, 10	1, 8	1, 5, 7
Contact resistance	2, 4, 6, 8, 10, 12	2, 6, 8, 10, 12, 16	2, 4, 6, 8	2, 4, 6	2, 4
Insulation resistance		3, 13			
Temperature rise		5, 15			
Voltage Proof	11	4, 14			
Cable retention force (axial)			9	7	
Cable retention force (90°)					6
Vibration Test	5				
Impact			5	5	
Separation force			7		
IPX5	3, 7				
IPX8 (this includes IPX7)	9				
Cold		7			
Dry heat		9			
Damp heat		11			
Thermal shock			3	3	
Thermal cycling with current load cyclic					3

Figure 2.

**NOTE**

(a) Minimum samples 5 of each part number per test group.

*Samples to be used:*

*2213600-1 assembled with 12 AWG and 14 AWG stranded wire.*

*2213600-2 assembled with 14 AWG and 16 AWG stranded wire.*

*2213600-3 assembled with 16 AWG and 18 AWG stranded wire.*

*2213800-1 assembled with 18 AWG solid and 18 AWG stranded wire.*

*2213800-4 assembled with 20 AWG solid and 20 AWG stranded wire.*

*2213800-4 assembled with 22 AWG solid and 22 AWG stranded wire.*

(b) Numbers indicate sequence in which tests are performed.

(c) 221600-7 & -9 has been released based on the temperature rise (502-193194).

(d) 2213917-y, 2213918-y and 2213920-y qualification will be done by testing each part number 5 samples per group B.