

REVISIONS				
P.	LTH	DESCRIPTION	DATE	APPROV
5		REVISED	25OCT2016	MS JW

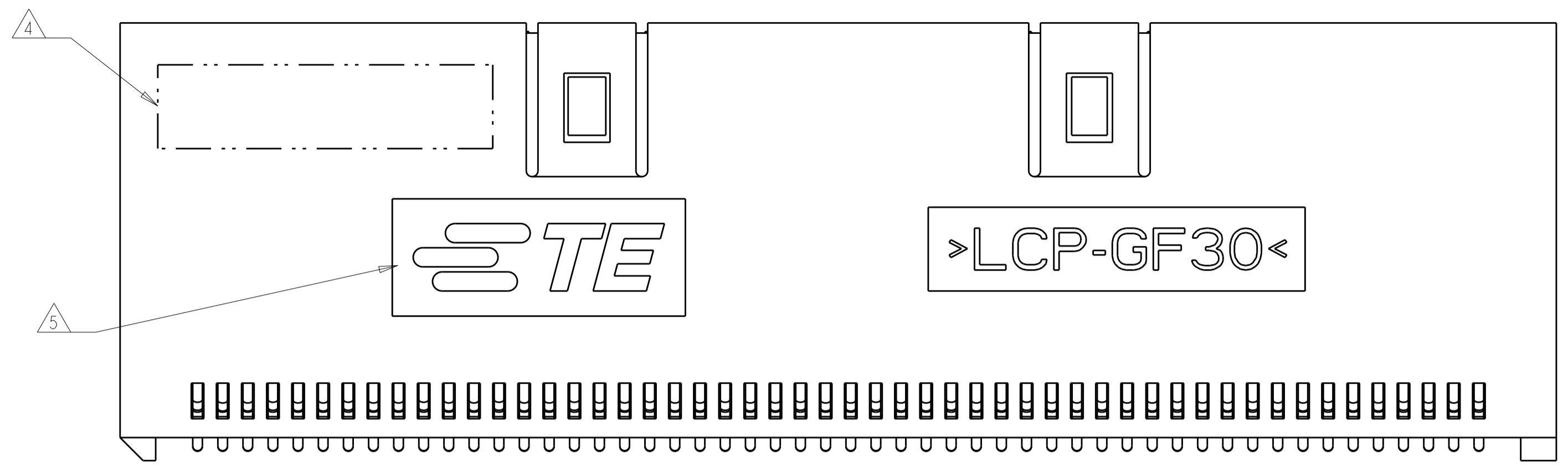

- ⚠ MATERIALS:
 HOUSING- POLYESTER LCP. UL 94V-0
 SIGNAL CONTACT- COPPER ALLOY.
 GROUND CONTACT- COPPER ALLOY.
- ⚠ CONTACT FINISH: CONFORMS TO THE REQUIREMENTS OF TE PRODUCT SPECIFICATION 108-XXXX, BASED ON EIA/ECA-364-1000.01A, (CONTROLLED ENVIRONMENT APPLICATIONS) ON MATING INTERFACE, GOLD FLASH ON SOLDER TAIL.
- ⚠ DATUM AND BASIC DIMENSION ESTABLISHED BY CUSTOMER.
- ⚠ PART NUMBER AND DATE CODE MARKED IN APPROXIMATE AREA SHOWN.
- ⚠ MANUFACTURER'S LOGO APPROXIMATELY AS SHOWN.

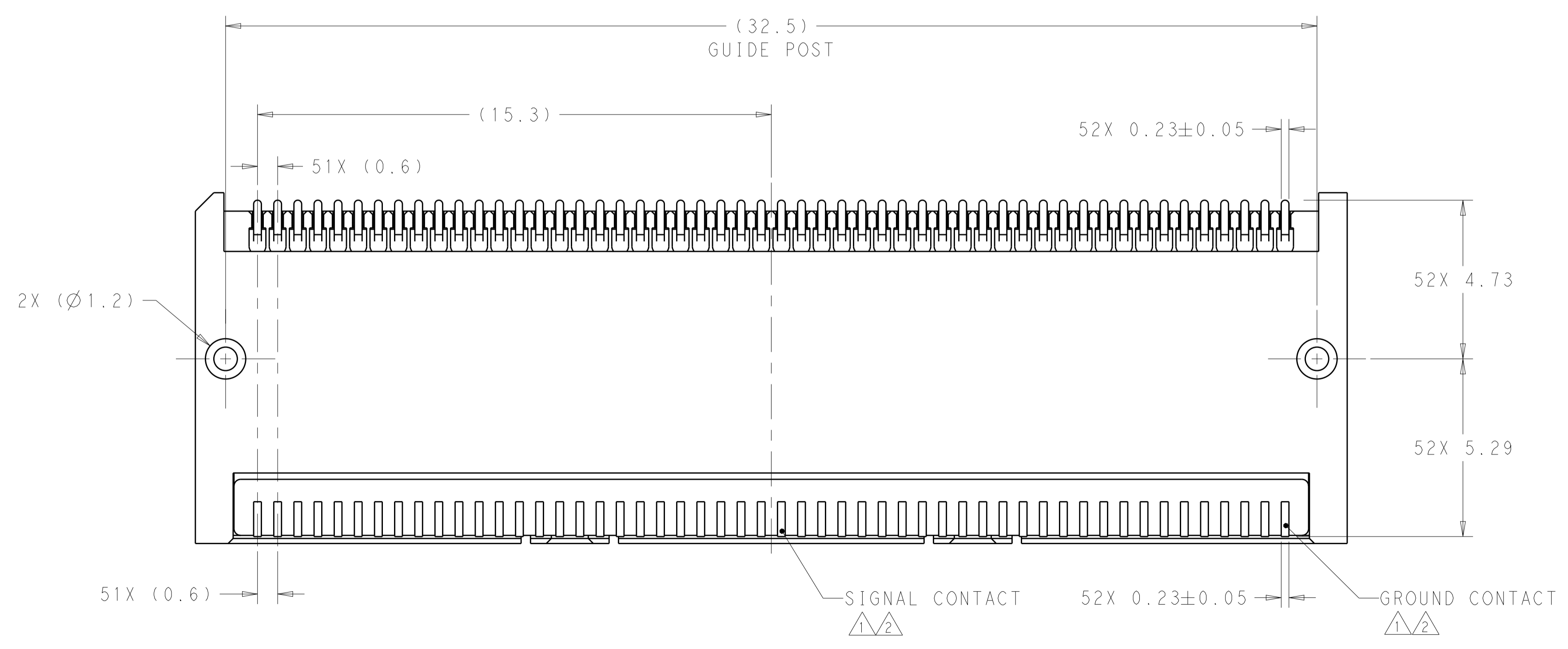
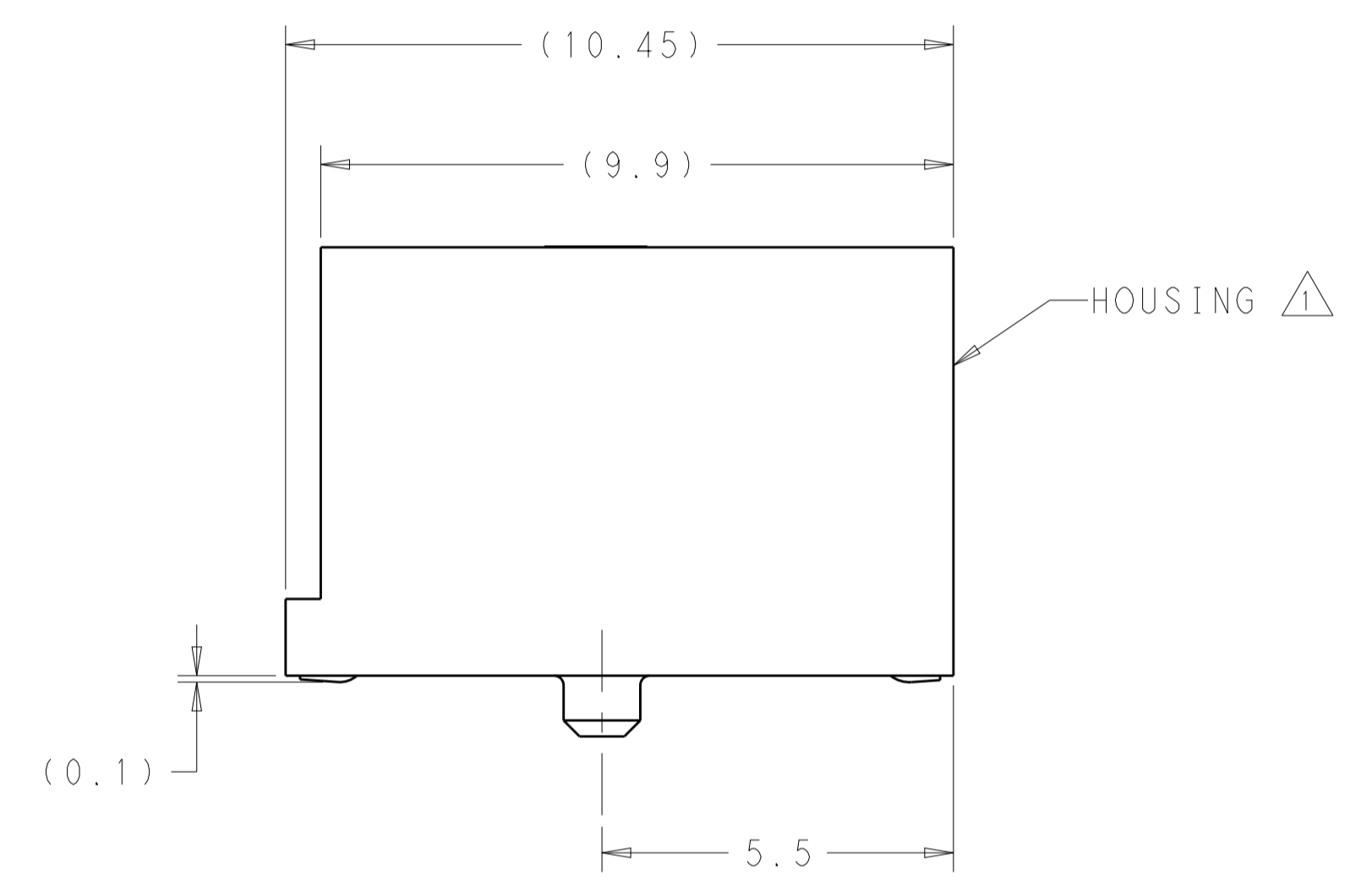
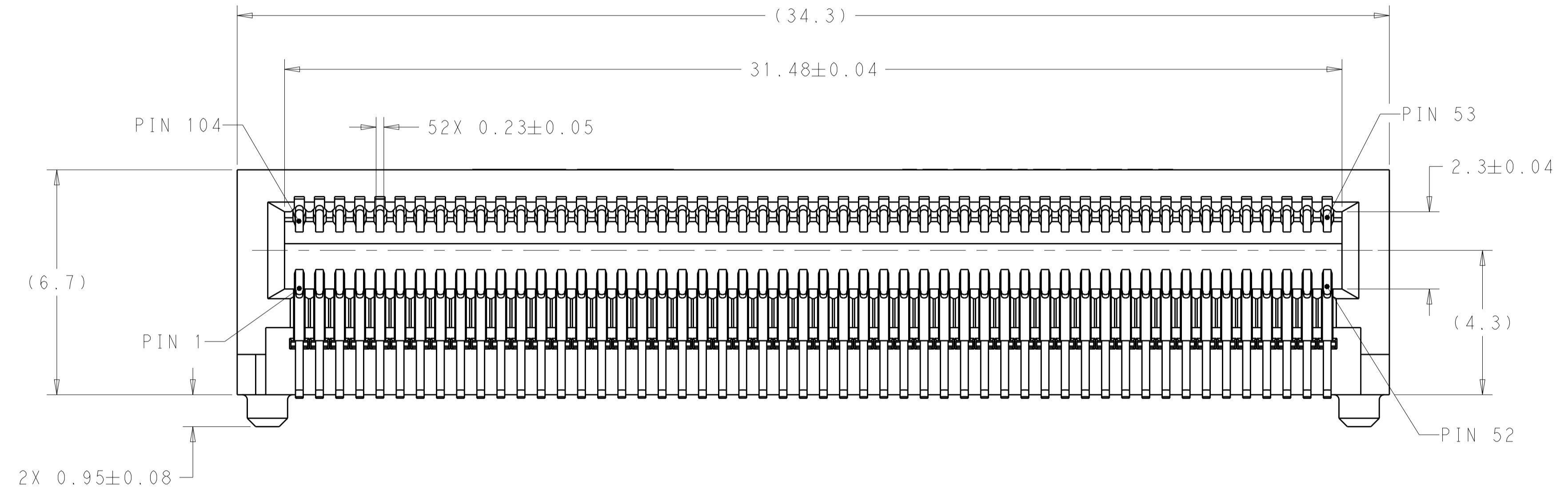

THIS PRODUCT HAS NOT COMPLETED VALIDATION AND QUALIFICATION TESTING

PRELIMINARY
 NOT RELEASED FOR PRODUCTION

2274845-1
 PART NUMBER

THIS DRAWING IS A CONTROLLED DOCUMENT.		OWN: B MATTHEWS 04DEC2014		TE Connectivity
DIMENSIONS:		CHK: M SCHWITZ 04DEC2014		
TOLERANCES UNLESS OTHERWISE SPECIFIED:		APPR: M SCHWITZ 04DEC2014	NAME: CONNECTOR ASSEMBLY RECEPTACLE, CFP2	
mm	0 PLC ±0.1	PRODUCT SPEC: -		
	1 PLC ±0.1	APPLICATION SPEC: -		
	2 PLC ±0.1	SIZE: A1		
	3 PLC ±	CAGE CODE: 2274845		
	4 PLC ±	DRAWING NO: 2274845		
	ANGLES ±	RESTRICTED TO: -		
	FINISH ±	WEIGHT: -		
MATERIAL: -		CUSTOMER DRAWING		
		SCALE: 10:1 SHEET 1 OF 3 REV 5		

REVISIONS				
P.	LTN.	DESCRIPTION	DATE	APVD.
-	-	SEE SHEET 1	-	-

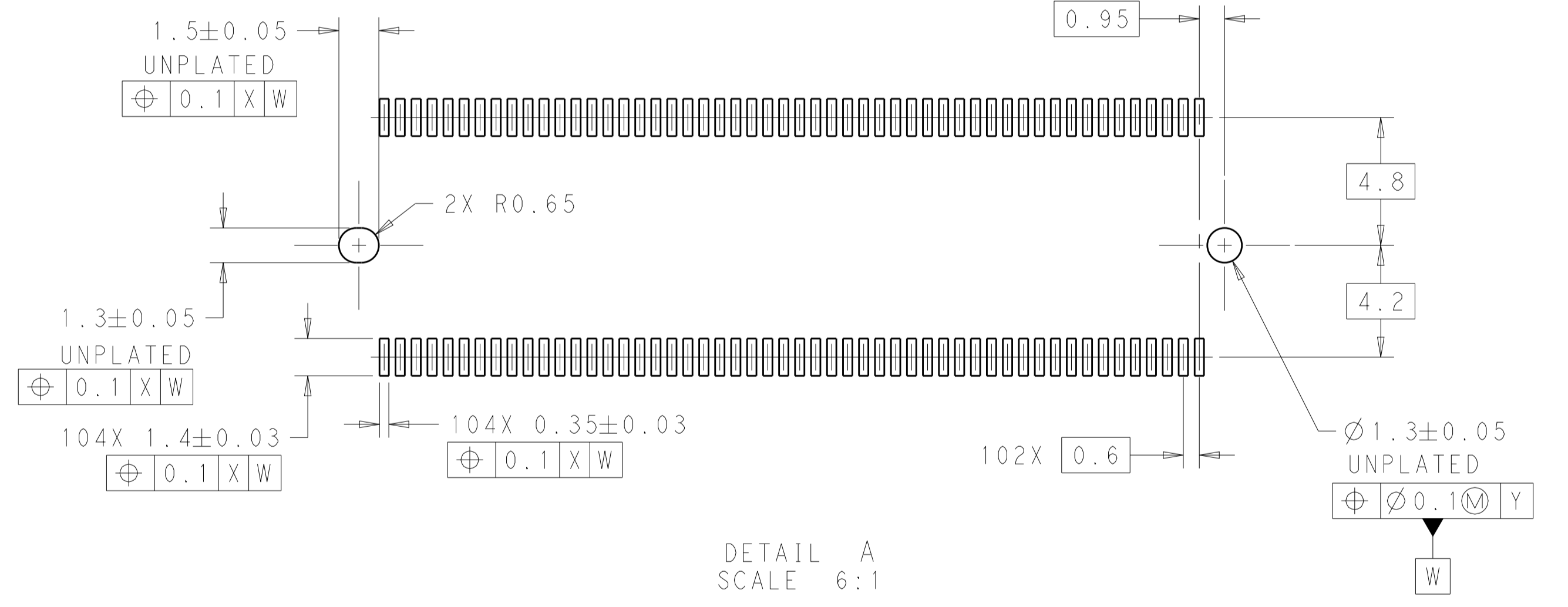
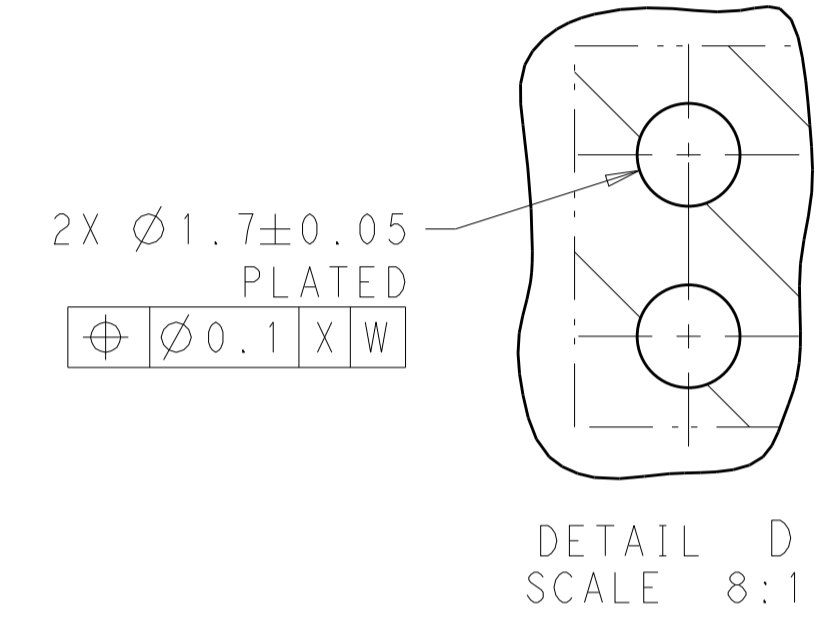
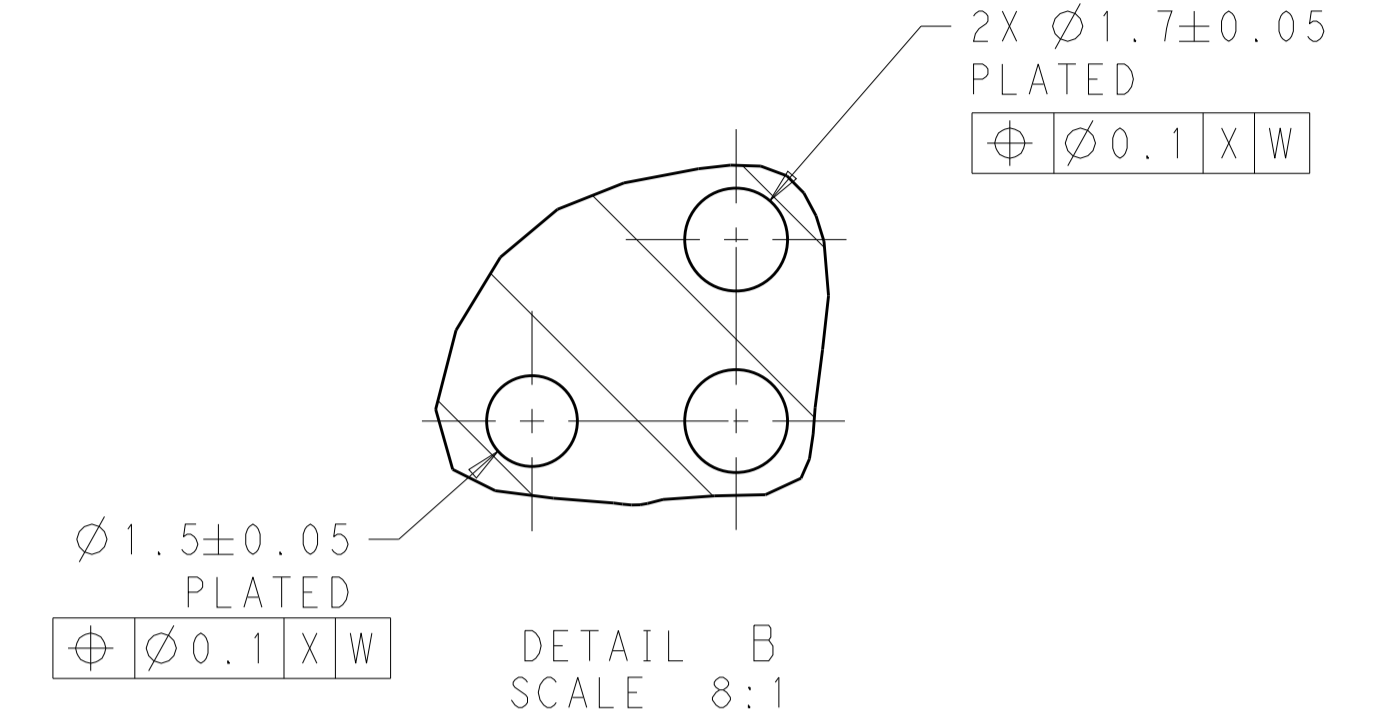
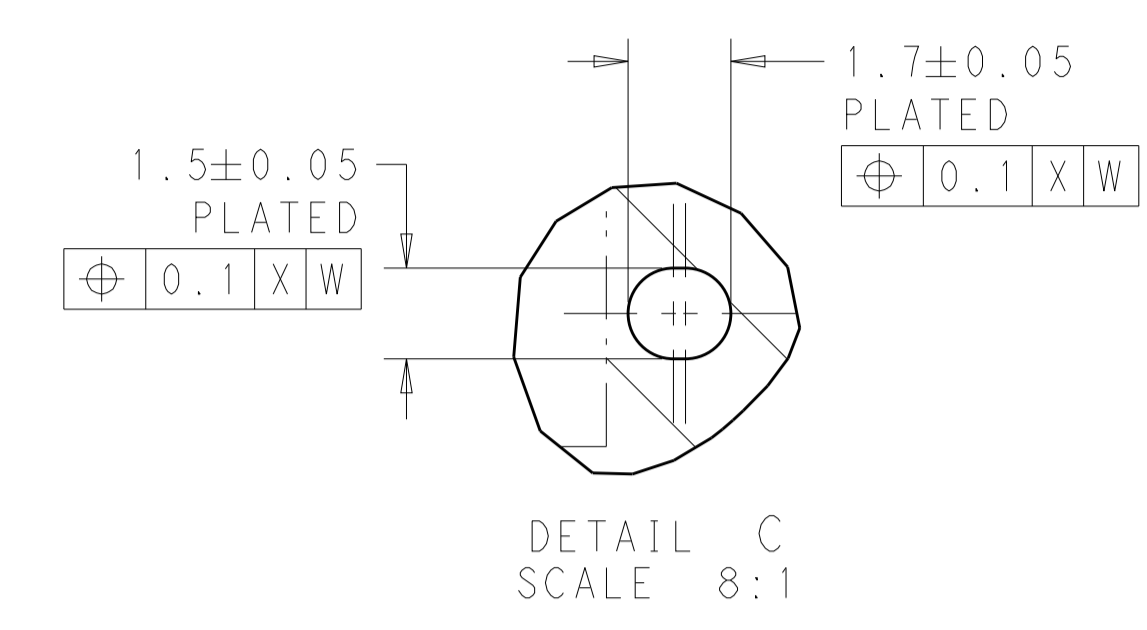
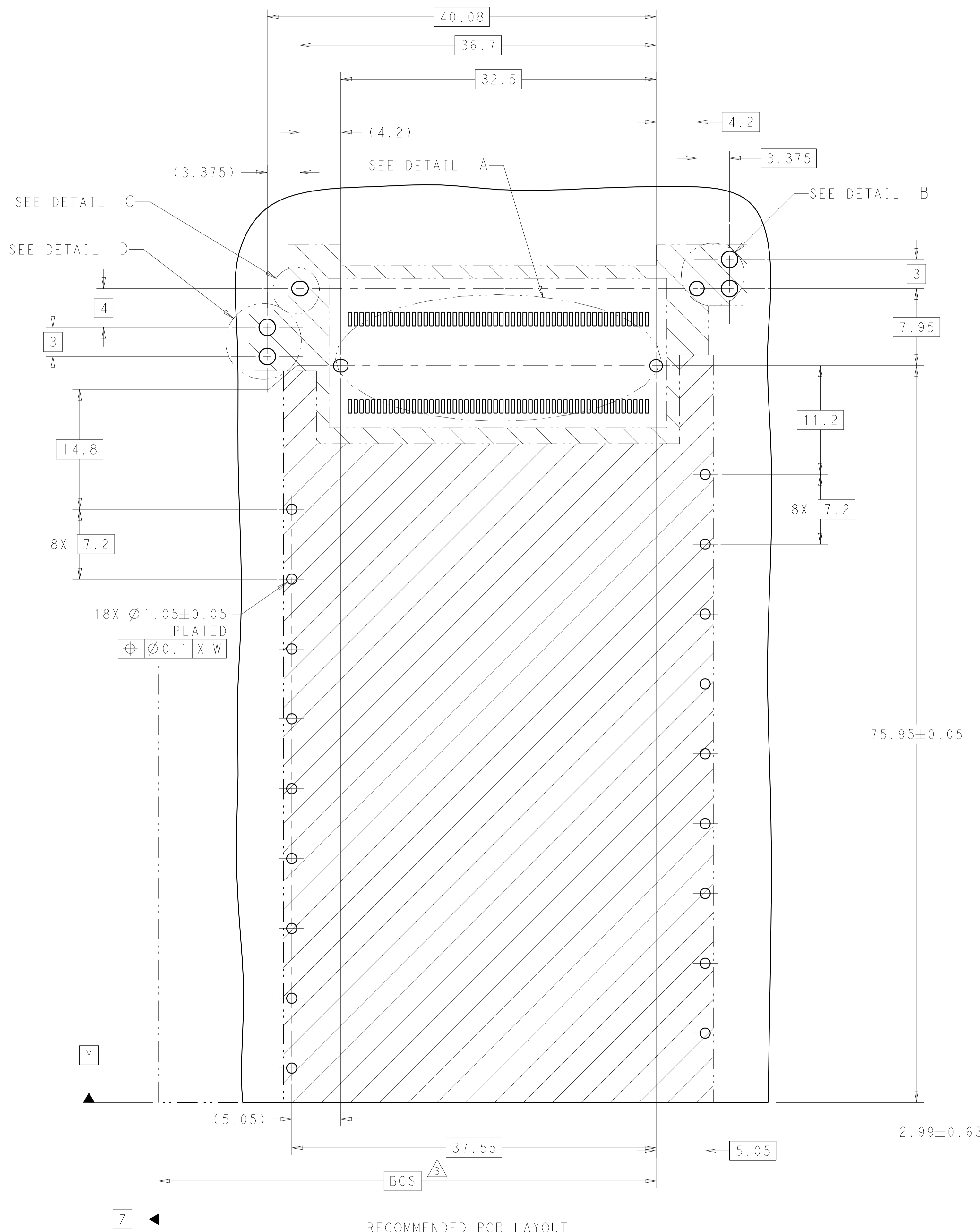

THIS PRODUCT HAS NOT COMPLETED VALIDATION AND QUALIFICATION TESTING

RECOMMENDED PCB LAYOUT
 SCALE 4:1
 SINGLE SIDED APPLICATION
 1X1 CONFIGURATION SHOWN

**PRELIMINARY
 NOT RELEASED FOR PRODUCTION**

THIS DRAWING IS A CONTROLLED DOCUMENT.		DWN: B. MATTHEWS 04DEC2014	 TE Connectivity
DIMENSIONS: mm		CHK: M. SCHMITT 04DEC2014	
TOLERANCES UNLESS OTHERWISE SPECIFIED:		APVD: M. SCHMITT 04DEC2014	NAME: CONNECTOR ASSEMBLY, RECEPTACLE, CFP2
0 PLC ±0.1	1 PLC ±0.1	PRODUCT SPEC	SIZE: CAGE CODE: DRAWING NO:
2 PLC ±0.1	3 PLC ±0.1	APPLICATION SPEC	RESTRICTED TO:
4 PLC ±	ANGLES ±	WEIGHT	A100779C=2274845
MATERIAL:	FINISH:	CUSTOMER DRAWING	SCALE: 10:1 SHEET 2 OF 3 REV 5

REVISIONS				
P.	LTH	DESCRIPTION	DATE	APVD
-	-	SEE SHEET 1	-	-

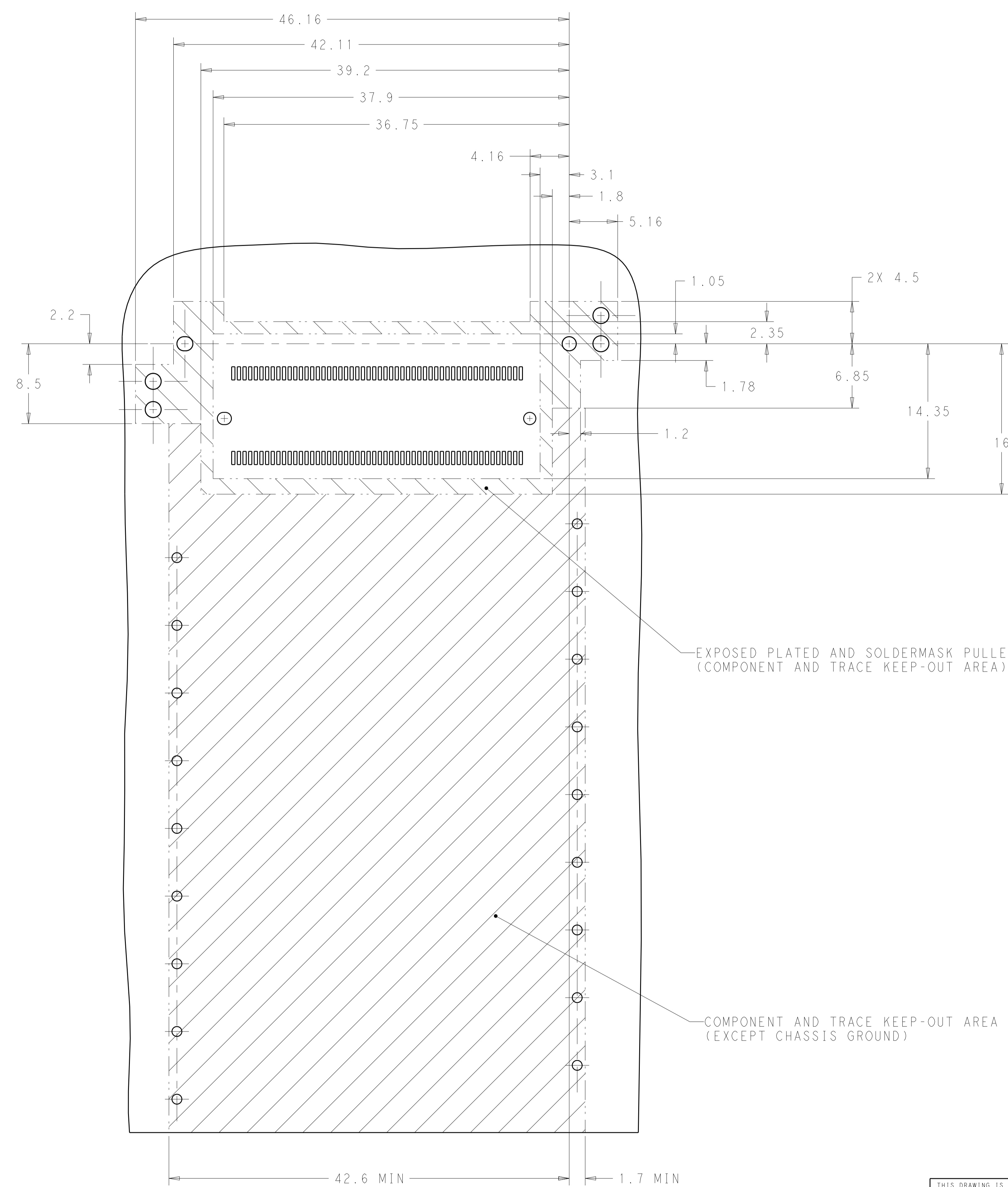

EXPOSED PLATED AND SOLDERMASK PULLED BACK
 (COMPONENT AND TRACE KEEP-OUT AREA)

COMPONENT AND TRACE KEEP-OUT AREA
 (EXCEPT CHASSIS GROUND)

THIS PRODUCT HAS NOT COMPLETED VALIDATION AND QUALIFICATION TESTING

SCALE 4:1

PRELIMINARY NOT RELEASED FOR PRODUCTION

THIS DRAWING IS A CONTROLLED DOCUMENT.		DWN: B. MATTHEWS 04DEC2014	TE Connectivity
DIMENSIONS: mm		CHK: M. SCHMITT 04DEC2014	
TOLERANCES UNLESS OTHERWISE SPECIFIED:		APVD: M. SCHMITT 04DEC2014	NAME: CONNECTOR ASSEMBLY, RECEPTACLE, CFP2
0 PLC ±0.1	1 PLC ±0.1	PRODUCT SPEC	SIZE: A100779
2 PLC ±0.1	3 PLC ±0.1	APPLICATION SPEC	CAGE CODE: C=2274845
4 PLC ±	ANGLES ±	WEIGHT	RESTRICTED TO
MATERIAL	FINISH	CUSTOMER DRAWING	SCALE: 10:1 SHEET 3 OF 3 REV 5