

## 2-320665-1 Product Details



**2-320665-1**

TE Internal Number: 2-320665-1



### Ring and Spade Tongue Terminals

 Always EU RoHS/ELV Compliant (Statement of Compliance)

#### Product Highlights:

- Terminal Shape = Spade Tongue
- Receptacle Style = Straight
- Body Style = PLASTI-GRIP
- Barrel Type = Closed Barrel
- Wire/Cable Type = Regular Wire

### Documentation & Additional Information

#### Product Drawings:

- [TERMINAL, SPADE, PLASTI-GRIP WIRE SIZE : 22-16 AWG](#) (PDF, English)

#### Catalog Pages/Data Sheets:

- None Available

#### Product Specifications:

- None Available

#### Application Specifications:

- [PLASTI-GRIP Terminals and Splices](#) (PDF, English)

#### Instruction Sheets:

- None Available

#### CAD Files: (CAD Format & Compression Information)

- [2D Drawing](#) (DXF, Version N)
- [3D Model](#) (IGES, Version N)
- [3D Model](#) (STEP, Version N)

#### Related Products:

- [Tooling](#)

### Product Features (Please use the Product Drawing for all design activity)

#### Product Type Features:

- Terminal Shape = Spade Tongue
- Receptacle Style = Straight
- Barrel Type = Closed Barrel
- Wire/Cable Type = Regular Wire
- Insulation = Yes
- Insulation Support = Insulation Support
- Stud Diameter (mm [in]) = 3.68 [0.145]
- Stud Size = 6 [M3.5]
- Shape = SPADE-021
- Heavy Duty = No
- Finish = Tin
- Color = Red

#### Electrical Characteristics:

- Voltage (VAC) = 600

#### Termination Features:

- Wire/Cable Size (CMA) = 509 - 3,260

#### Dimensions:

- Insulation Diameter (mm [in]) = 2.67 - 3.56 [.105 - .140]

#### Body Features:

- Body Style = PLASTI-GRIP
- Wire Range (mm [AWG]) = 0.30-1.40<sup>2</sup> [22-16]
- Material = Copper
- Tongue Material Thickness (mm [in]) = 0.79 [0.031]
- Insulation Material = Vinyl

#### Industry Standards:

- Government/Industry Qualification = No
- RoHS/ELV Compliance = RoHS compliant, ELV compliant
- Lead Free Solder Processes = Not relevant for lead free process
- RoHS/ELV Compliance History = Always was RoHS compliant

#### Packaging Features:

- Packaging Method = Tape Mounted
- Packaging Quantity = 5,000/Reel

#### Other:

- Brand = AMP

THIS DRAWING IS UNPUBLISHED. RELEASED FOR PUBLICATION  
 © COPYRIGHT - By - ALL RIGHTS RESERVED.

LOC	DIST	REVISIONS					
G	14	P	LTR	DESCRIPTION	DATE	DWN	APVD
			G2	REVISED PER ECO-11-004820	11MAR11	RK	HMR

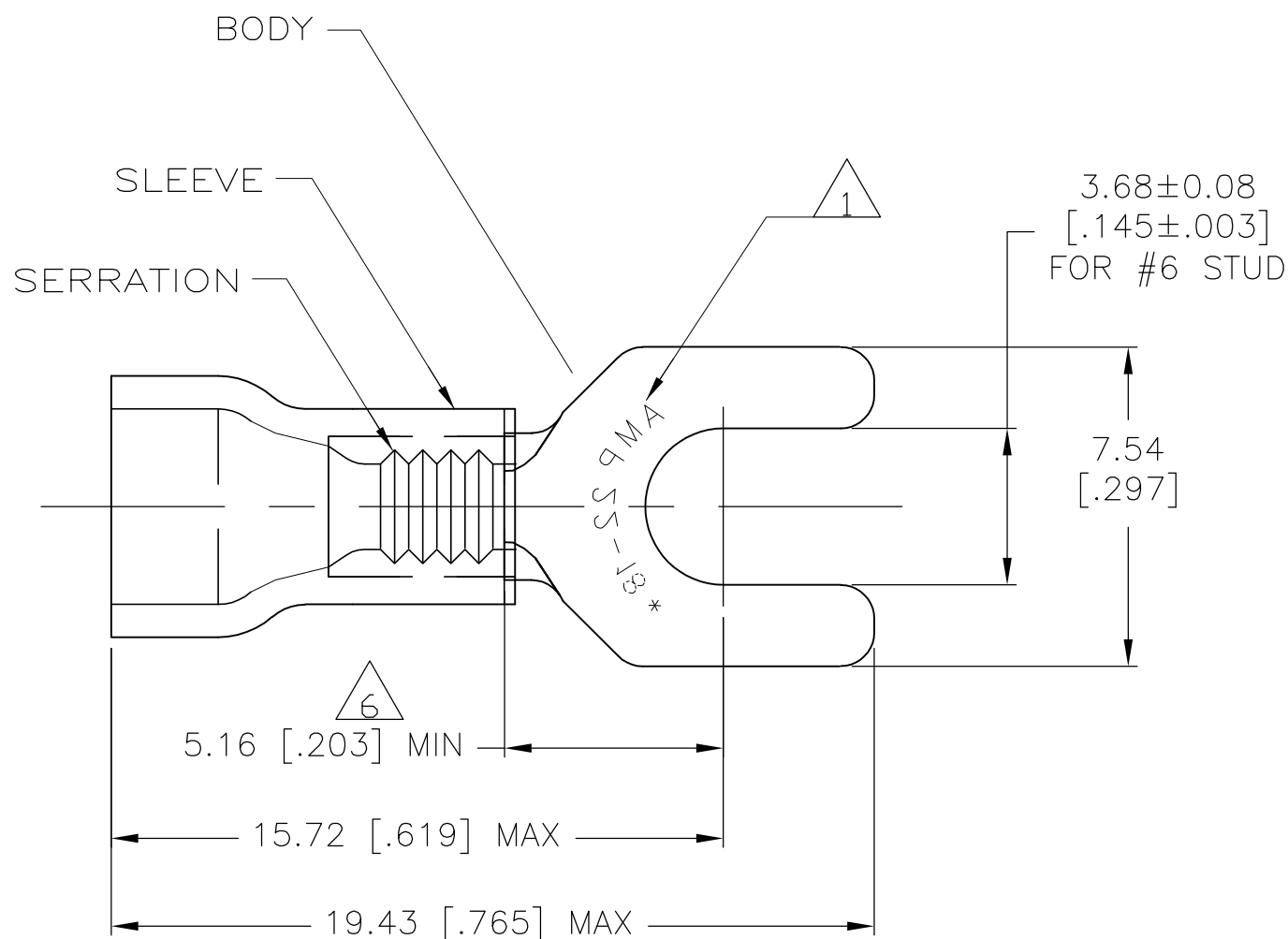

<b>AMP</b> WIRE RANGE	Listed FILE E13288	LR7189 Certified
22-16 AWG SOLID OR STRANDED	22-16 AWG SOLID OR STRANDED	22-16 AWG SOLID OR STRANDED

- ① STAMP AMP 22-18\* APPROX AS SHOWN  
22-16 TERMINALS ARE STAMPED 22-18 IN ACCORDANCE WITH MILITARY SPEC MIL-T-7928  
COMMERCIAL WIRE RANGE IS 22-16
- 2. WIRE INSUL DIA, 2.67 TO 3.56 [.105 TO .140]
- 3. TONGUE MATL THK, 0.79 ± 0.05 [.031 ± .002]
- ④ SUPERSEDED BY 8-320665-5
- ⑤ MATERIAL: BODY - CU PER ASTM B152  
SLEEVE - PVC, COLOR - RED
- ⑥ APPLIES FROM THE METAL EDGE OF BARREL TO THE CENTER OF THE STUD.

④	50	LOOSE PIECE, BAG	8-320665-5
	5	LOOSE PIECE, BLS	8-320665-4
	100	LOOSE PIECE, BOX	8-320665-1
	5000	ON TAPE, REEL	2-320665-1
	1000	LOOSE PIECE	320665
	QTY	PACKAGE TYPE	PART NO

AMP INCORPORATED CUSTOMER SERVICE SYSTEMS		MAX RECOMMENDED OPERATING TEMPERATURE: 105°C	THIS DRAWING IS A CONTROLLED DOCUMENT.		DWN G VINSON 28NOV94	TE Connectivity				
FOR ADDITIONAL PRODUCT INFORMATION OR COPIES OF DRAWINGS AND TECHNICAL DOCUMENTS	PRODUCT INFORMATION CENTER 1-800-522-6752	VOLTAGE RATING: 600V MAX (1000V FIXTURE OR SIGN)	DIMENSIONS: mm [INCHES]	TOLERANCES UNLESS OTHERWISE SPECIFIED:	CHK M ELLIS 28NOV94				NAME	
FOR APPLICATION TOOLING INFORMATION	TOOLING ASSISTANCE CENTER 1-800-722-1111	CIRCULAR MIL AREA: 0.26-1.65mm² [509-3260] SOLID OR STRANDED		0 PLC ± - 1 PLC ± - 2 PLC ± 0.20 [.008] 3 PLC ± - 4 PLC ± - ANGLES ± -	APVD G NGO 28NOV94	TERMINAL, SPADE, PLASTI-GRIP WIRE SIZE : 22-16 AWG				
FOR ORDER ENTRY	1-800-526-5142	THIS DRAWING IS A CONTROLLED DOCUMENT FOR AMP INCORPORATED. IT IS SUBJECT TO CHANGE AND THE CONTROLLING ENGINEERING ORGANIZATION SHOULD BE CONTACTED FOR THE LATEST REVISION.	MATERIAL - ⑤ -	FINISH -	PRODUCT SPEC UL 486A	SIZE A3	CAGE CODE 00779	DRAWING NO G-320665	RESTRICTED TO -	
					WEIGHT -	CUSTOMER DRAWING		SCALE 6:1	SHEET 1 OF 1	REV G2