

Distributed by:

**JAMECO**<sup>®</sup>  
ELECTRONICS

**www.Jameco.com ♦ 1-800-831-4242**

The content and copyrights of the attached  
material are the property of its owner.

Jameco Part Number 836553

THIS DRAWING IS UNPUBLISHED. RELEASED FOR PUBLICATION  
 © COPYRIGHT BY TYCO ELECTRONICS CORPORATION. ALL RIGHTS RESERVED.

| LOC | DIST | REVISIONS |     |                       |         |     |      |
|-----|------|-----------|-----|-----------------------|---------|-----|------|
|     |      | P         | LTR | DESCRIPTION           | DATE    | DWN | APVD |
| G   | 14   |           | P1  | REV PER ECR 06-001832 | 22APR06 | JR  | TM   |

|                                |                                |                                |
|--------------------------------|--------------------------------|--------------------------------|
| <b>AMP</b><br>WIRE RANGE       | Listed                         | LR7189<br>Certified            |
| 12-10 AWG<br>SOLID OR STRANDED | 12-10 AWG<br>SOLID OR STRANDED | 12-10 AWG<br>SOLID OR STRANDED |

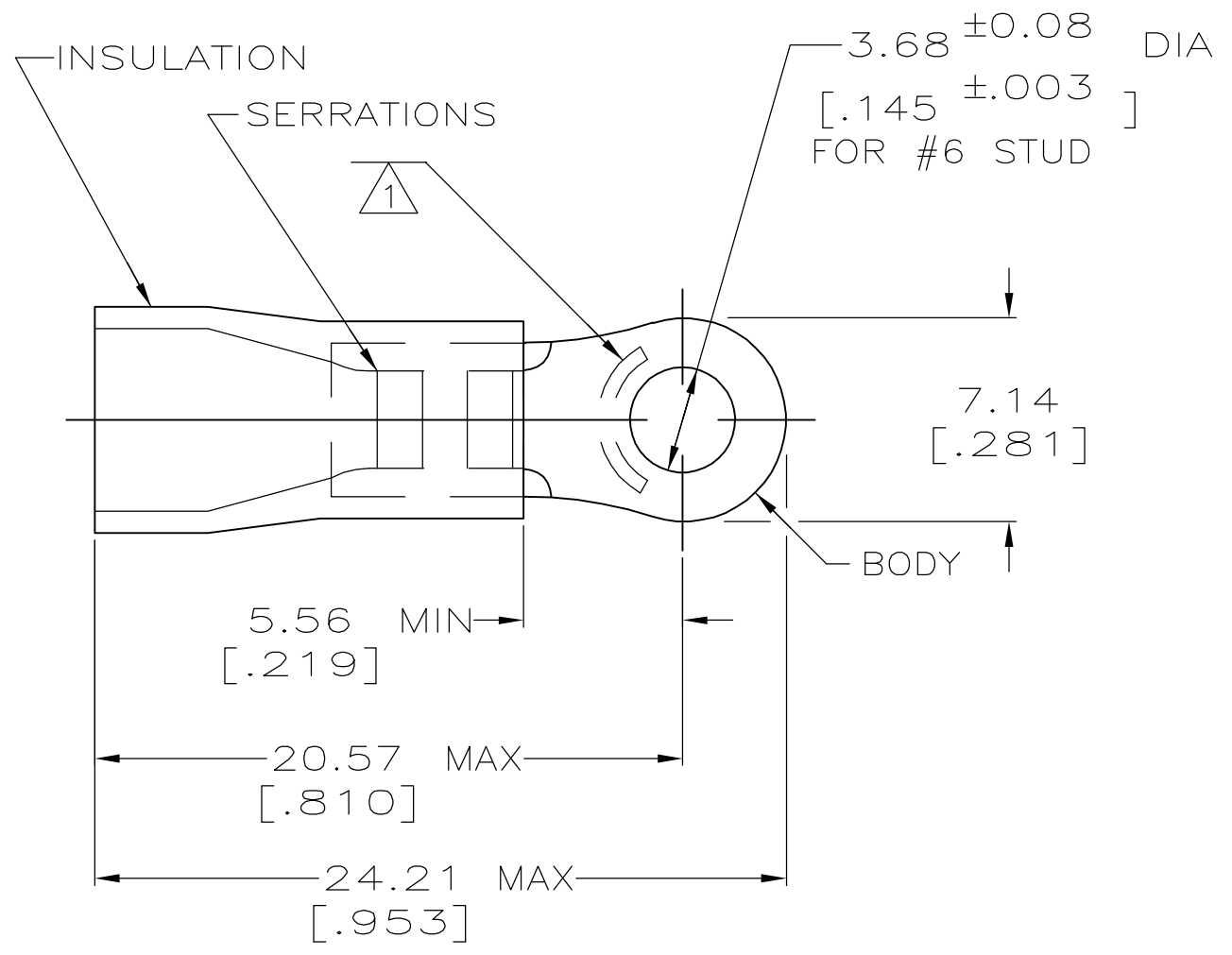

- △ 1 STAMP AMP 12-10\* APPROX AS SHOWN
- 2 WIRE INSULATION DIA: .150-.250
- 3 TONGUE MATERIAL THK: 0.99<sup>±0.05</sup> [.039<sup>±.002</sup>]
- △ 4 MATERIAL: BODY - CU PER ASTM B152  
SLEEVE - PVC, COLOR - YELLOW

| QTY  | PACKAGE TYPE  | PART NO.  |
|------|---------------|-----------|
| 50   | LOOSE PC,BOX  | 8-34852-2 |
| 2000 | ON TAPE, REEL | 2-34852-1 |
| -    | LOOSE PIECE   | 34852     |

|  |  |   |  |  |                                   |   |                    |                       |                    |
|--|--|---|--|--|-----------------------------------|---|--------------------|-----------------------|--------------------|
| <b>AMP INCORPORATED<br/>CUSTOMER SERVICE SYSTEMS</b>                             |  | MAX RECOMMENDED OPERATING TEMPERATURE:<br>105°C [221°F]   | THIS DRAWING IS A CONTROLLED DOCUMENT. |  | DWN<br>DK SCHRUM 08/06/92         | Tyco Electronics Corporation<br>Harrisburg, Pa 17105-3608 |                    |                       |                    |
| FOR ADDITIONAL PRODUCT INFORMATION OR COPIES OF DRAWINGS AND TECHNICAL DOCUMENTS | PRODUCT INFORMATION CENTER<br>1-800-522-6752 | VOLTAGE RATING:<br>N/A  | DIMENSIONS:<br>MM [INCHES]             | TOLERANCES UNLESS OTHERWISE SPECIFIED:   | CHK<br>RE HERSEY 11/10/92         | NAME<br>M BARNABA   |                    |                       |                    |
| FOR APPLICATION TOOLING INFORMATION  | TOOLING ASSISTANCE CENTER<br>1-800-722-1111  | CIRCULAR MIL AREA:<br>2.62-6.64mm <sup>2</sup> [5,180-13,100]<br>SOLID OR STRANDED  |  | 0 PLC ± -<br>1 PLC ± -<br>2 PLC ± 0.20[.008]<br>3 PLC ± -<br>4 PLC ± -<br>ANGLES ± - | APVD<br>M BARNABA 11/10/92        | PRODUCT SPEC<br>108-1034                                  |                    |                       |                    |
| FOR ORDER ENTRY  | 1-800-526-5142                               | THIS DRAWING IS A CONTROLLED DOCUMENT FOR AMP INCORPORATED. IT IS SUBJECT TO CHANGE AND THE CONTROLLING ENGINEERING ORGANIZATION SHOULD BE CONTACTED FOR THE LATEST REVISION. | MATERIAL<br>- △ 4                      | FINISH<br>TIN PER ASTM B545  | APPLICATION SPEC<br>NOT AVAILABLE | SIZE<br>A3  | CAGE CODE<br>00779 | DRAWING NO<br>C-34852 | RESTRICTED TO<br>- |
| CUSTOMER DRAWING   |  |   |  |  | WEIGHT<br>-                       | SCALE<br>4:1  | SHEET<br>1 OF 1    | REV<br>P1             |                    |