



Have a Question?
 Chat with a Product
 Information Specialist

What can we help you find?

[Products](#) |
 [Industries](#) |
 [Resources](#) |
 [About TE](#) |
 [My Account](#) |
 [Innovation](#) |
 [Support Center](#)

2-5329083-1 Product Details

[Share](#) |
 [Print](#) |
 [Email](#)



2-5329083-1

TE Internal Number: 2-5329083-1

Active

BNC RF Connectors

Always EU RoHS/ELV Compliant (Statement of Compliance)

Product Highlights:

- Connector - RF
- Plug
- Connector Style = Plug
- Applies To Coaxial Cable
- Coaxial Cable Termination Type = Crimp

[View all Features](#)

Quick Links

- ▶ [Pricing & Availability](#)
- ▶ [Search for Tooling](#)
- ▶ [Product Feature Selector](#)
- ▶ [Contact Us About This Product](#)

[Add to My Part List](#) |
 [Request Sample](#) |
 [Find Similar Products](#) |
 [Buy Product](#)

Documentation & Additional Information	
<p>Product Drawings:</p> <ul style="list-style-type: none"> • PLUG, SERIES BNC (PDF, English) <p>Catalog Pages/Data Sheets:</p> <ul style="list-style-type: none"> • None Available <p>Product Specifications:</p> <ul style="list-style-type: none"> • None Available <p>Application Specifications:</p> <ul style="list-style-type: none"> • None Available <p>Instruction Sheets:</p> <ul style="list-style-type: none"> • None Available <p>CAD Files:</p> <ul style="list-style-type: none"> • None Available 	<p>Related Products:</p> <ul style="list-style-type: none"> • Tooling

[List all Documents](#)

Product Features (Please use the Product Drawing for all design activity)	
<p>Product Type Features:</p> <ul style="list-style-type: none"> • Product Type = Connector - RF • Gender = Plug • Grade = Military • Sealed = No • Isolated = No • Dielectric Material = Polypropylene • Coupling Nut Material = Brass • Solder Terminal = Without <p>Mechanical Attachment:</p> <ul style="list-style-type: none"> • Surface Mountable = No • Hardware Included = No • Panel Mount Retention = Without <p>Electrical Characteristics:</p> <ul style="list-style-type: none"> • Connector Impedance (Ω) = 50 <p>Termination Features:</p> <ul style="list-style-type: none"> • Coaxial Cable Termination Type = Crimp • Crimp Type = Single <p>Body Features:</p> <ul style="list-style-type: none"> • Body Style = Straight • Body Plating = Silver • Body Insulation = Without • Polarized = No 	<p>Contact Features:</p> <ul style="list-style-type: none"> • Center Contact Material = Brass • Center Contact Plating = Gold <p>Housing Features:</p> <ul style="list-style-type: none"> • Connector Style = Plug <p>Configuration Features:</p> <ul style="list-style-type: none"> • Coaxial Cable Type (RG/U or Mfg.) = 124, 140, 210, 59, 59A, 59B, 62, 62A, 62B • Number of Ports = 1 <p>Industry Standards:</p> <ul style="list-style-type: none"> • Government/Industry Qualification = No • RoHS/ELV Compliance = RoHS compliant, ELV compliant • Lead Free Solder Processes = Not relevant for lead free process • RoHS/ELV Compliance History = Always was RoHS compliant <p>Conditions for Usage:</p> <ul style="list-style-type: none"> • Applies To = Coaxial Cable <p>Other:</p> <ul style="list-style-type: none"> • Brand = AMP

THIS DRAWING IS UNPUBLISHED. RELEASED FOR PUBLICATION
 © COPYRIGHT BY TYCO ELECTRONICS CORPORATION. ALL RIGHTS RESERVED.

Loc	DIST	REVISIONS			
P	LTR	DESCRIPTION	DATE	DWN	APVD
AJ	16	0	REV PER EC-0S14-0496-04	03FEB2005	AF JL

1. CRIMP TOOL: 69141-1
2. RG-59/U,59A/U,59B/U,62/U,62A/U,62B/U,124/U,140/U AND 210/U
3. SEE I.S. 1799-1

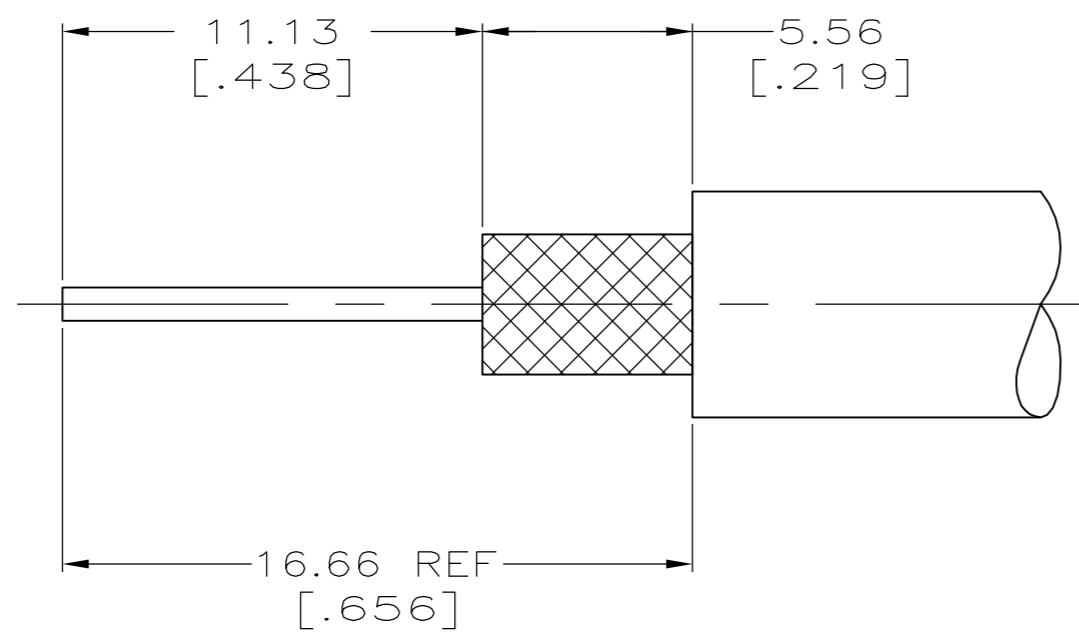

RECOMMENDED STRIP LENGTH

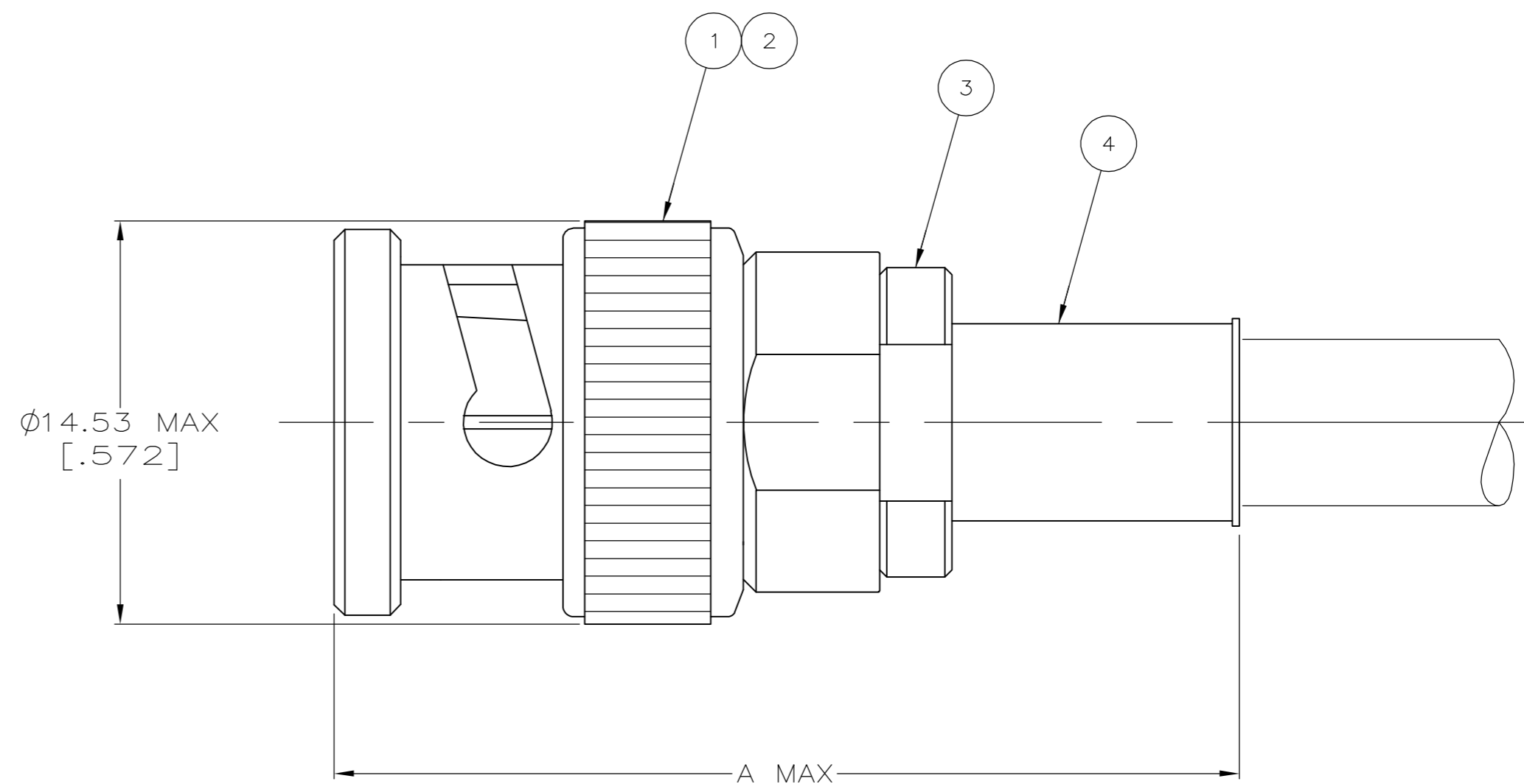

34.93 [1.375]	\triangle	.416 OZ	9-329041-0	9-50780-6	2-329106-1	9-329327-1	2-5329083-1
A	CABLE	WEIGHT	4 FERRULE QTY=1	3 CRIMP END ASSEMBLY QTY=1	2 GASKET QTY=1	1 PLUG ASSEMBLY QTY=1	PART NUMBER

THIS DRAWING IS A CONTROLLED DOCUMENT.

DWN	A. FERNANDEZ	03FEB2005	 Tyco Electronics Corporation Harrisburg, PA 17105-3608
CHK	J. HAVENER	03FEB2005	
APVD	J. LIPPERT	03FEB2005	
NAME			
DIMENSIONS:	TOLERANCES UNLESS OTHERWISE SPECIFIED:		PLUG, SERIES BNC
MM [INCHES]	0 PLC ± - 1 PLC ± - 2 PLC ± 0.41 [.016] 3 PLC ± - 4 PLC ± - ANGLES ± - FINISH -		
MATERIAL	FINISH		SIZE A2 CAGE CODE 00779 DRAWING NO C=5329083 RESTRICTED TO -
CUSTOMER DRAWING			SCALE 5:1 SHEET 1 OF 1 REV 0

5329083