

2-5330060-1 Product Details

[Share](#) [Print](#) [Email](#)



2-5330060-1

TE Internal Number: 2-5330060-1

 Active

BNC RF Connectors

 Always EU RoHS/ELV Compliant (Statement of Compliance)

Product Highlights:

- Connector - RF
- Jack
- Connector Style = Jack
- Applies To Coaxial Cable
- Coaxial Cable Termination Type = Crimp

[View all Features](#)

Quick Links

- ▶ [Pricing & Availability](#)
- ▶ [Search for Tooling](#)
- ▶ [Product Feature Selector](#)
- ▶ [Contact Us About This Product](#)

[Add to My Part List](#)

[Request Sample](#)

[Find Similar Products](#)

[Buy Product](#)

Documentation & Additional Information

Product Drawings:

- None Available

Catalog Pages/Data Sheets:

- None Available

Product Specifications:

- None Available

Application Specifications:

- None Available

Instruction Sheets:

- None Available

CAD Files:

- None Available

Related Products:

- [Tooling](#)

Product Features (Please use the Product Drawing for all design activity)

Product Type Features:

- [Product Type](#) = Connector - RF
- [Gender](#) = Jack
- [Grade](#) = Military
- [Sealed](#) = No
- [Isolated](#) = No
- [Dielectric Material](#) = Polypropylene
- [Coupling Nut Material](#) = Brass

Mechanical Attachment:

- [Surface Mountable](#) = No
- [Hardware Included](#) = No
- [Panel Mount Retention](#) = With
- [Panel Mount Retention Type](#) = Bulkhead
- [Panel Attachment Style](#) = Rear Mount

Electrical Characteristics:

- [Connector Impedance \(Ω\)](#) = 50

Termination Features:

- [Coaxial Cable Termination Type](#) = Crimp
- [Crimp Type](#) = Single

Contact Features:

- [Center Contact Material](#) = Beryllium Copper
- [Center Contact Plating](#) = Gold

Housing Features:

- [Connector Style](#) = Jack

Configuration Features:

- [Coaxial Cable Type \(RG/U or Mfg.\)](#) = 174, 188
- [Number of Ports](#) = 1
- [Solder Terminal](#) = Without

Industry Standards:

- [Government/Industry Qualification](#) = No
- [RoHS/ELV Compliance](#) = RoHS compliant, ELV compliant
- [Lead Free Solder Processes](#) = Not relevant for lead free process
- [RoHS/ELV Compliance History](#) = Always was RoHS compliant

Conditions for Usage:

- [Applies To](#) = Coaxial Cable

Body Features:

- [Body Style](#) = Straight
- [Body Plating](#) = Silver
- [Body Insulation](#) = Without
- [Polarized](#) = No

Other:

- Brand = TE Connectivity

Corporate Information

[About TE](#)
[Investors](#)
[News Room](#)
[Supplier Portal](#)
[Careers](#)
[Terms & Conditions](#)
[Privacy Policy](#)

Quick Links

[Distributor Inventory](#)
[Product Cross Reference](#)
[Documents & Drawings](#)
[Product Compliance Support Center](#)
[Site Map](#)

Customer Support

[Email or Chat With Us](#)
[Find a Phone Number](#)
[Knowledge Base](#)
[Manage Your Account](#)

Keep Me Informed

THIS DRAWING IS UNPUBLISHED. RELEASED FOR PUBLICATION
 © COPYRIGHT BY TYCO ELECTRONICS CORPORATION. ALL RIGHTS RESERVED.

LOC	DIST	REVISIONS			
P	LTR	DESCRIPTION	DATE	DWN	APVD
AJ	16	A	REV PER ECO 06-002539	06APR06	GB JH

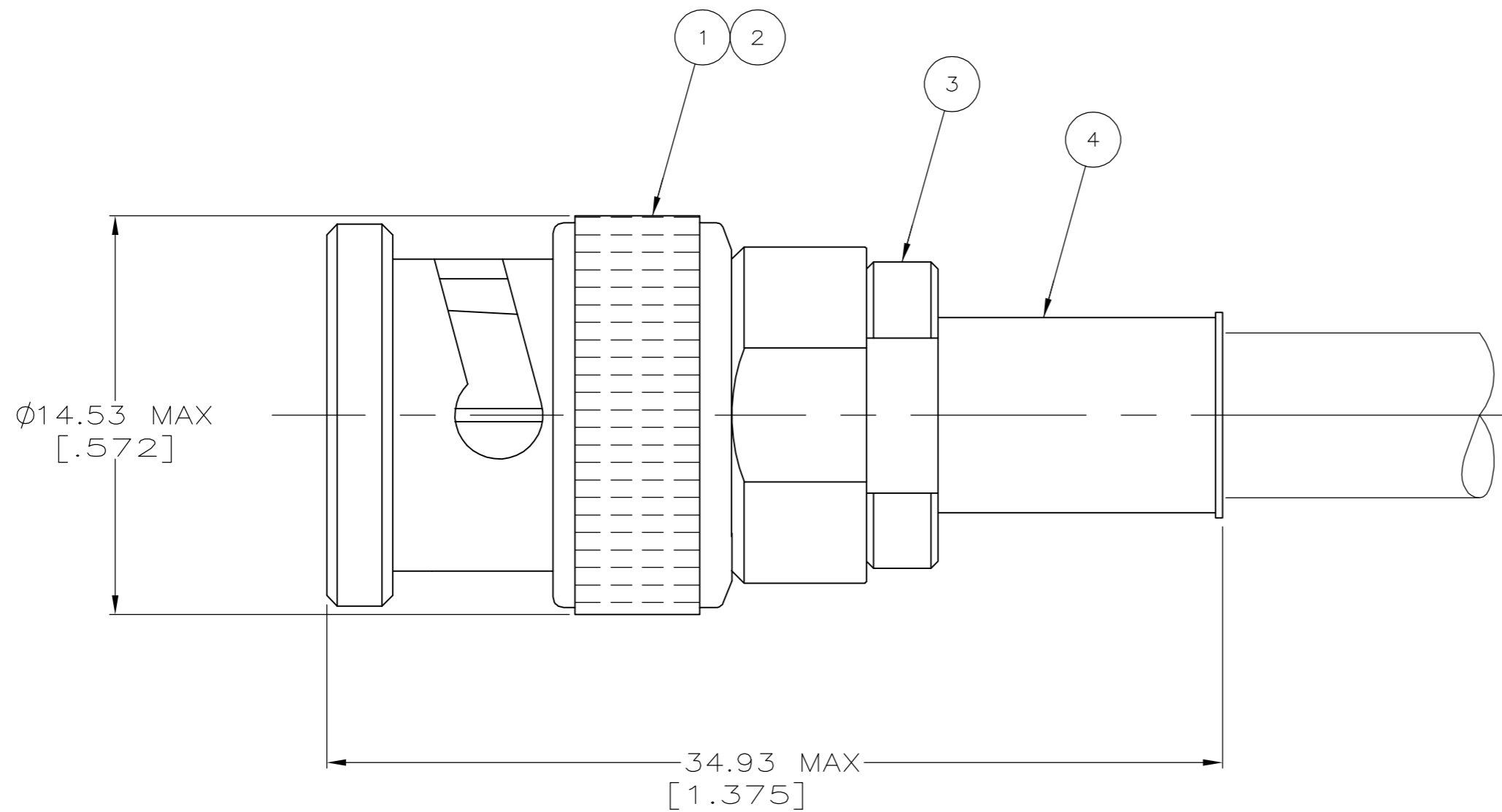

- 1. FOR CABLE: RG-59/U, 59A/U, 59B/U, 62/U, 62A/U, 62B/U, 124/U, 140/U, 210/U
- 2. USE INSTRUCTION SHEET 408-1799-1

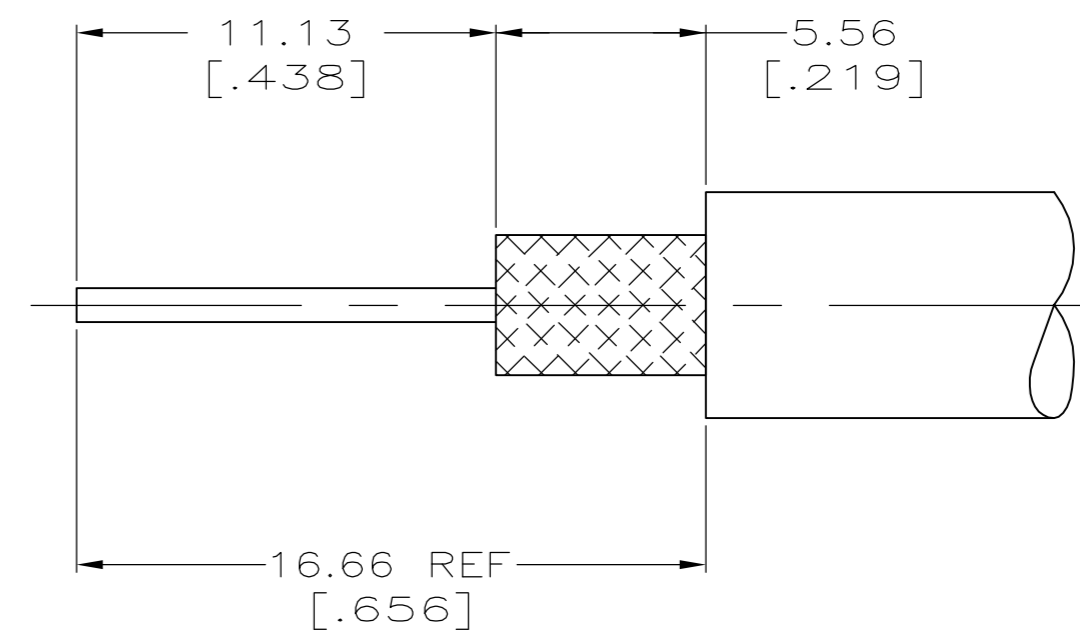

RECOMMENDED STRIP LENGTH
NO SCALE

1	69141-1	9-329041-0	9-50780-1	2-329106-1	9-329804-0	2-5329445-1
CABLE	CRIMP TOOL	4 FERRULE QTY=1	3 CRIMP END ASSEMBLY QTY=1	2 GASKET QTY=1	1 PLUG ASSEMBLY QTY=1	PART NUMBER

THIS DRAWING IS A CONTROLLED DOCUMENT.

DIMENSIONS: INCHES	TOLERANCES UNLESS OTHERWISE SPECIFIED:	DWN J. HAVENER 16SEP2005	Tyco Electronics Corporation Harrisburg, PA 17105-3608
	0 PLC ± -	CHK J. HAVENER 16SEP2005	
	1 PLC ± -	APVD J. LIPPERT 16SEP2005	
	2 PLC ± 0.41 [.016]	PRODUCT SPEC	
MATERIAL	FINISH	APPLICATION SPEC	NAME PLUG, BNC
		WEIGHT	SIZE A2
		CUSTOMER DRAWING	CAGE CODE 00779
			DRAWING NO C=5329445
			RESTRICTED TO
			SCALE 5:1
			SHEET 1 of 1
			REV A

329445

5329445