

THIS DRAWING IS UNPUBLISHED. RELEASED FOR PUBLICATION
 © COPYRIGHT BY TYCO ELECTRONICS CORPORATION. ALL RIGHTS RESERVED.

LOC		DIST		REVISIONS			
P	LTR	DESCRIPTION		DATE	DWN	APVD	
GP	00	S		REVISED PER ECO-08-008114	1JUL2008	ZMRCWR	

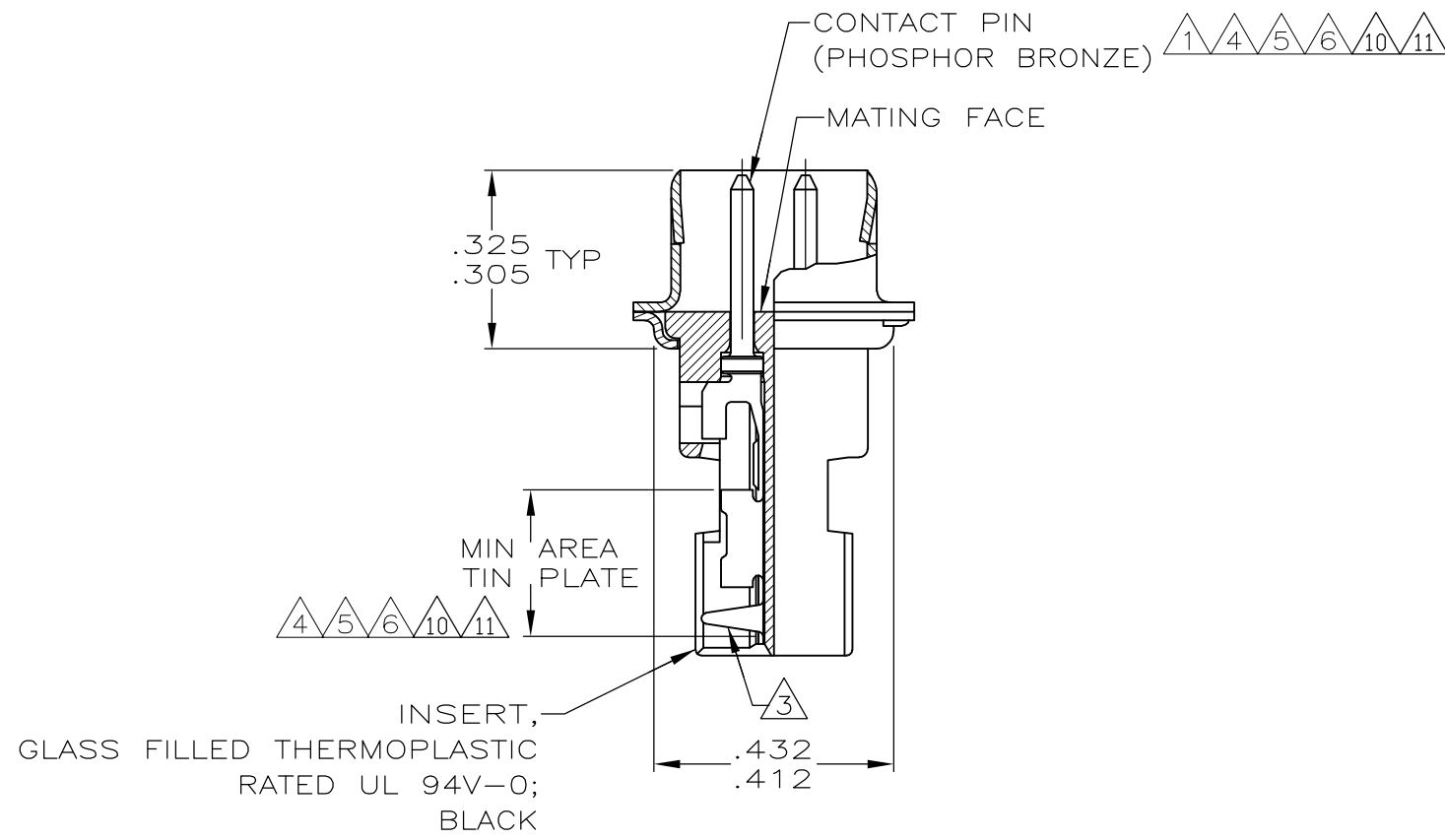
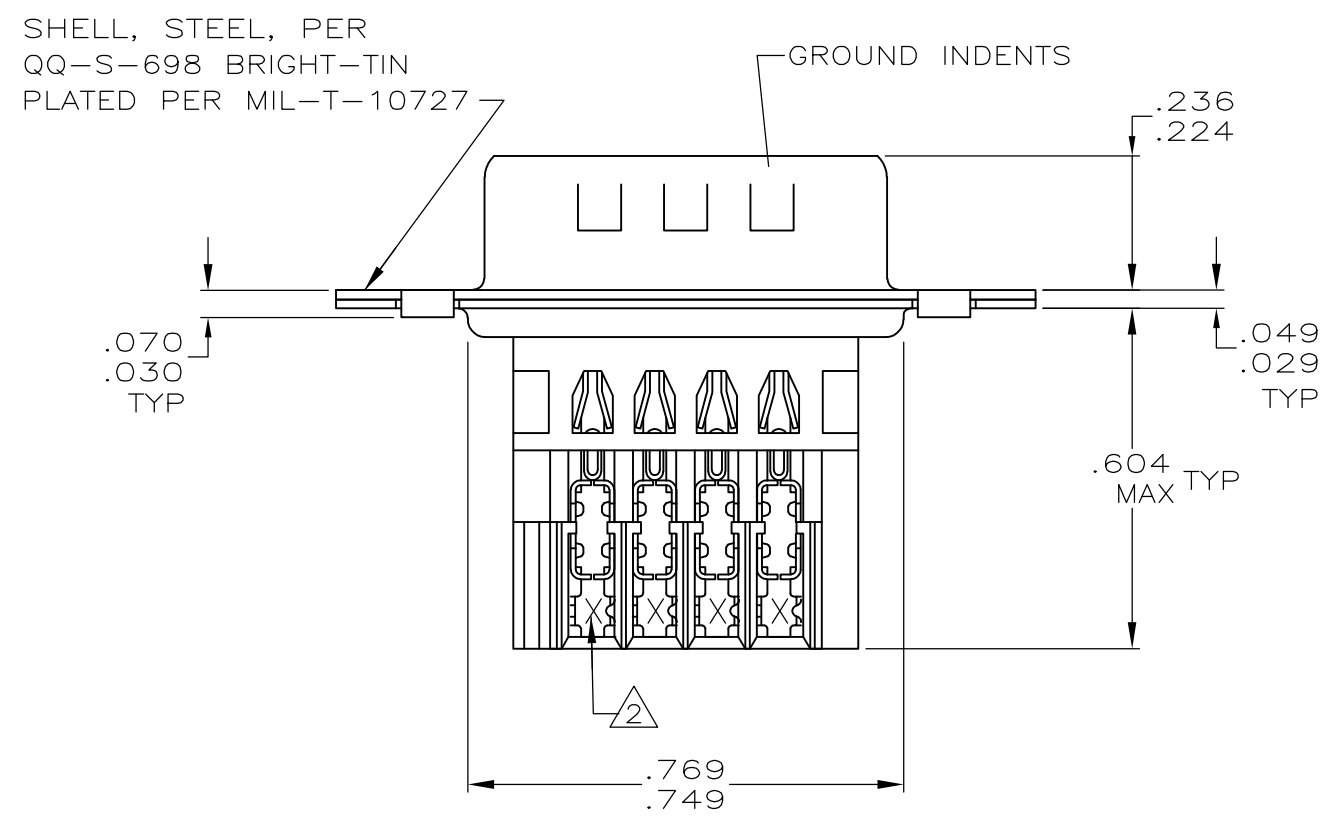
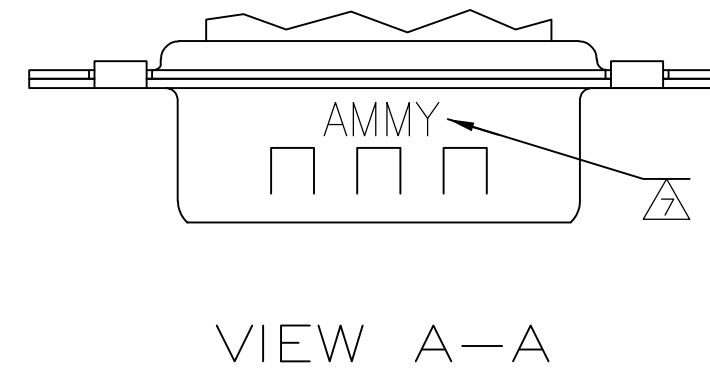
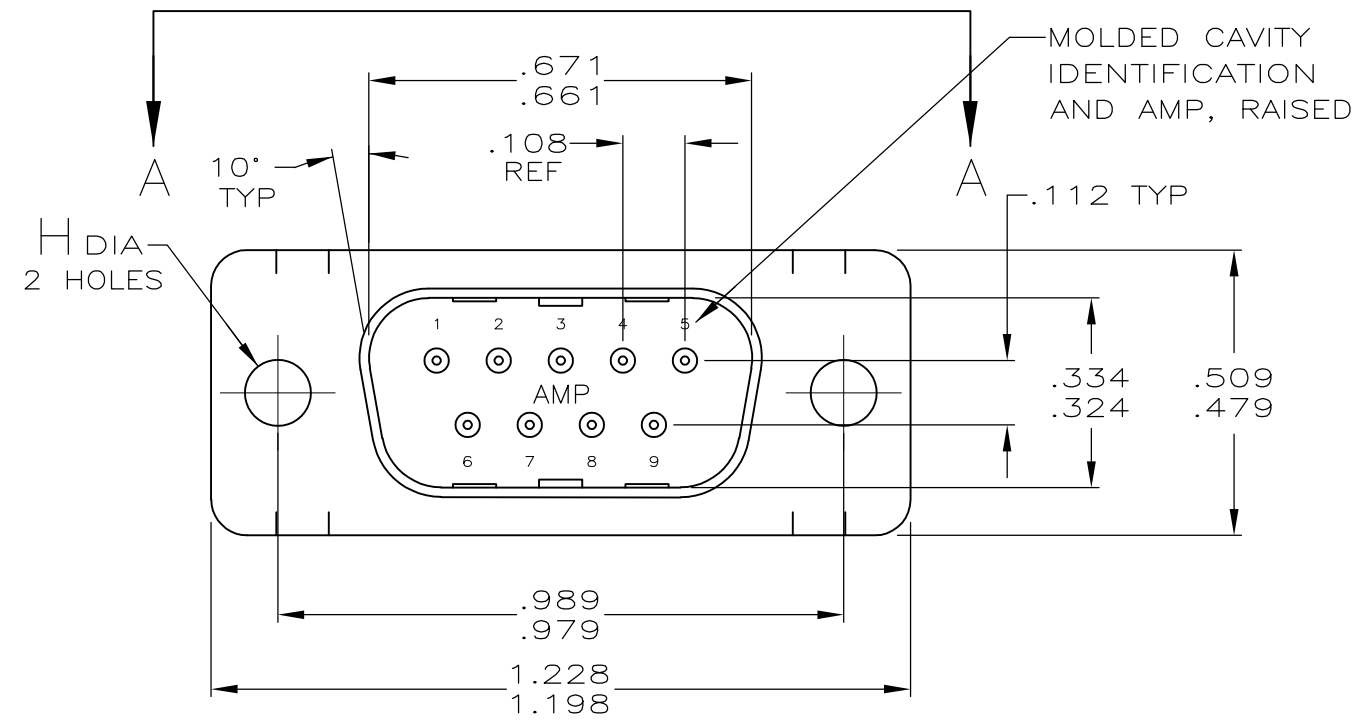

THIS DRAWING IS A CONTROLLED DOCUMENT.		DWN L. VAREAL - DOCK5 11-16-04	Tyco Electronics Corporation Harrisburg, PA 17105-3608	
DIMENSIONS: INCHES		CHK J. GERACE 11-16-04	NAME M. WALMSLEY 11-16-04	
TOLERANCES UNLESS OTHERWISE SPECIFIED: 0 PLC ± - 1 PLC ± - 2 PLC ± - 3 PLC ± .005 4 PLC ± - ANGLES ± 2°		APVD M. WALMSLEY 11-16-04	PRODUCT SPEC 108-40011	
MATERIAL SEE CALL OUT		FINISH SEE TABLE	APPLICATION SPEC 114-40002	RESTRICTED TO -
		WEIGHT -	SIZE A2	CAGE CODE 00779
		CUSTOMER DRAWING	DRAWING NO C=745492	SCALE 4:1
			SHEET 1 of 2	REV S

THIS DRAWING IS UNPUBLISHED. RELEASED FOR PUBLICATION
 © COPYRIGHT BY TYCO ELECTRONICS CORPORATION. ALL RIGHTS RESERVED.

LOC	DIST	REVISIONS			
P	LTR	DESCRIPTION	DATE	DWN	APVD
GP	00	SEE SHEET 1	-	-	-

- 1 HOUSING FULLY LOADED WITH CONTACTS.
- 2 NUMBER ON CONTACT INDICATES WIRE RANGE.
- 3 CONTACT INSULATION RANGE: .060 MAXIMUM O.D.
- 4 CONTACTS GOLD PLATED FOR A LENGTH OF .150 MIN FROM MATING END, .000030 MIN GOLD IN MATED AREA, .000100-.000200 BRIGHT TIN OR BRIGHT TIN-LEAD IN AREA SHOWN, ALL OVER .000050 MIN NICKEL UNDERPLATE ON ENTIRE CONTACT.
OR
CONTACTS GOLD PLATED FOR A LENGTH OF .150 MIN FROM MATING END, GOLD FLASH OVER .000030 MIN PALLADIUM-NICKEL IN MATED AREA, .000100-.000200 BRIGHT TIN OR BRIGHT TIN-LEAD IN AREA SHOWN, ALL OVER .000050 MIN NICKEL UNDERPLATE ON ENTIRE CONTACT.
- 5 GOLD PLATED FOR LENGTH OF .150 MIN FROM MATING END, GOLD FLASH IN MATED AREA. .000100-.000200 BRIGHT TIN OR BRIGHT IN TIN-LEAD AREA SHOWN. .000030 NICKEL UNDERPLATE ON ENTIRE CONTACT.
- 6 GOLD PLATED FOR LENGTH OF .150 MIN FROM MATING END, .000050 MIN GOLD IN MATED AREA. .000100-.000200 BRIGHT TIN OR BRIGHT IN TIN-LEAD AREA SHOWN. .000050 NICKEL UNDERPLATE ON ENTIRE CONTACT.
- 7 SPECIAL DATE CODE IN THIS APPROXIMATE AREA.
A; MM = MONTH; Y = LAST DIGIT OF YEAR.
- 8 OBSOLETE.
- 9 SUPERSEDED BY 745492-1
- 10 CONTACTS GOLD PLATED FOR A LENGTH OF .150 MIN FROM MATING END, .000030 MIN GOLD IN MATED AREA, .000100-.000200 MATTE TIN IN AREA SHOWN, ALL OVER .000050 MIN NICKEL UNDERPLATE ON ENTIRE CONTACT.
OR
CONTACTS GOLD PLATED FOR A LENGTH OF .150 MIN FROM MATING END, GOLD FLASH OVER PALLADIUM-NICKEL, .000030 MIN TOTAL IN MATED AREA, .000100-.000200 MATTE TIN IN AREA SHOWN, ALL OVER .000050 MIN NICKEL UNDERPLATE ON ENTIRE CONTACT.
- 11 CONTACTS PLATED GOLD FLASH FOR A LENGTH OF .150 MIN FROM MATING END, .000100-.000200 MATTE TIN IN AREA SHOWN, ALL OVER .000030 MIN NICKEL UNDERPLATE ON ENTIRE CONTACT.

STANDARD	.125 .115	11	2	#22-26	2-745492-0
STANDARD	.125 .115	10	3	#20-22	1-745492-9
STANDARD	.125 .115	10	2	#22-26	1-745492-8
STANDARD	.125 .115	10	1	#26-30	1-745492-7
SMALL PACK	.125 .115	5	2	#22-26	1-745492-5
STANDARD	.125 .115	6	2	#22-26	1-745492-3
			3	#20-22	1-745492-2
STANDARD	.156 .146	5	2	#22-26	1-745492-1
			1	#26-30	1-745492-0
			3	#20-22	745492-9
STANDARD	.156 .146	4	2	#22-26	745492-8
			1	#26-30	745492-7
			3	#20-22	745492-6
STANDARD	.125 .115	5	2	#22-26	745492-5
			1	#26-30	745492-4
			3	#20-22	745492-3
STANDARD	.125 .115	4	2	#22-26	745492-2
			1	#26-30	745492-1
			PACKAGING	H	CONTACT FINISH

THIS DRAWING IS A CONTROLLED DOCUMENT.		DWN L. VAREAL - DOCKS 11-16-04	Tyco Electronics Corporation Harrisburg, PA 17105-3608	
DIMENSIONS: INCHES		CHK J. GERACE 11-16-04	NAME M. WALMSLEY 11-16-04	
TOLERANCES UNLESS OTHERWISE SPECIFIED: 0 PLC ± - 1 PLC ± - 2 PLC ± - 3 PLC ± .005 4 PLC ± - ANGLES ± 2'		APVD M. WALMSLEY 11-16-04	PRODUCT SPEC 108-40011	
MATERIAL SEE CALL OUT		FINISH SEE TABLE	APPLICATION SPEC 114-40002	RESTRICTED TO -
		WEIGHT -	SIZE A2	CAGE CODE 00779
		CUSTOMER DRAWING		DRAWING NO C=745492
		SCALE 4:1	SHEET 2 of 2	REV S