

THIS DRAWING IS UNPUBLISHED. RELEASED FOR PUBLICATION 2002
 © COPYRIGHT 2002 BY - ALL RIGHTS RESERVED.

CONNECTOR OVERALL DIMENSIONS WITH COVER KIT AND LEVER ASSEMBLED

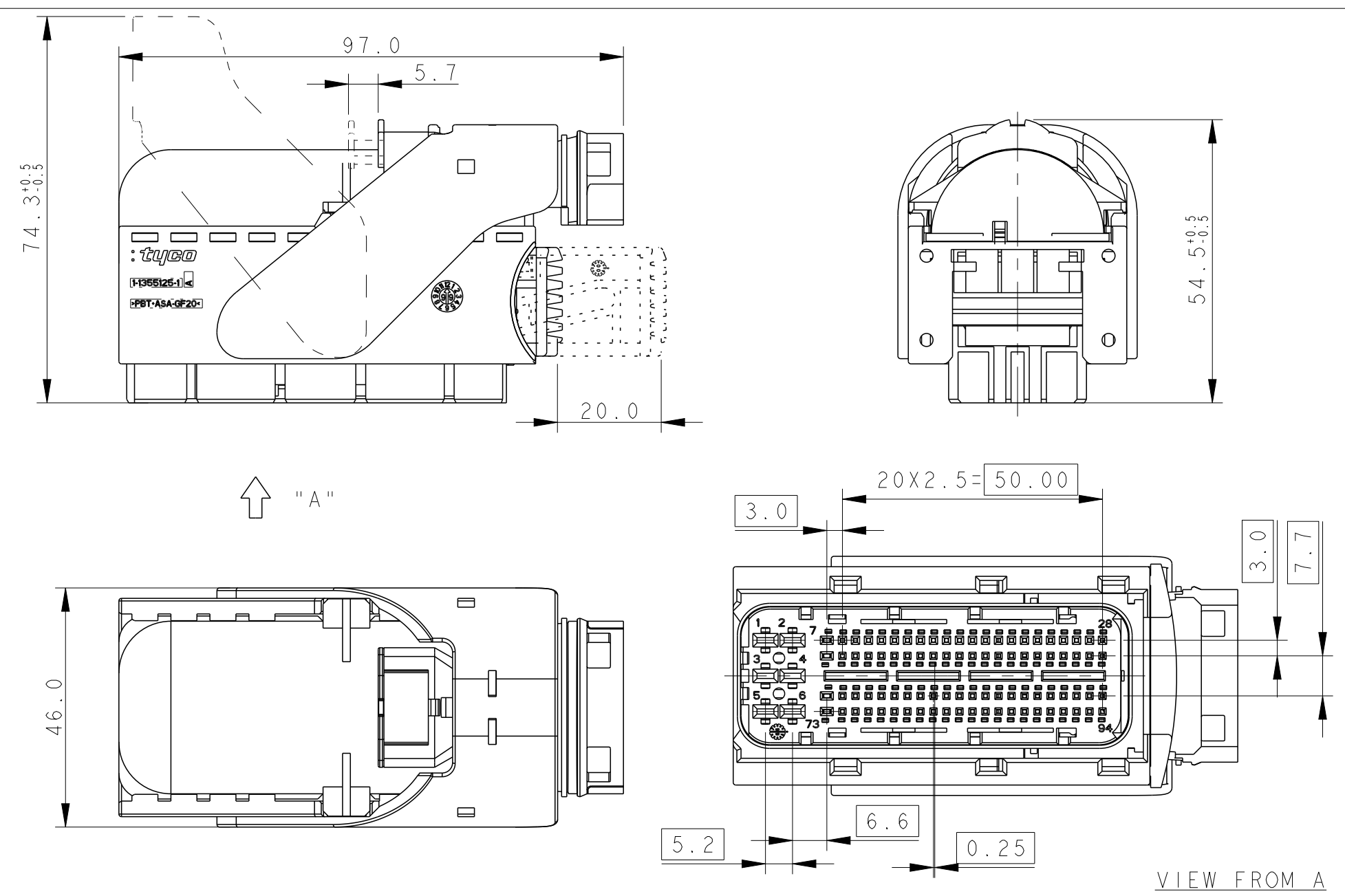

VIEW FROM WIRE INSERTION SIDE

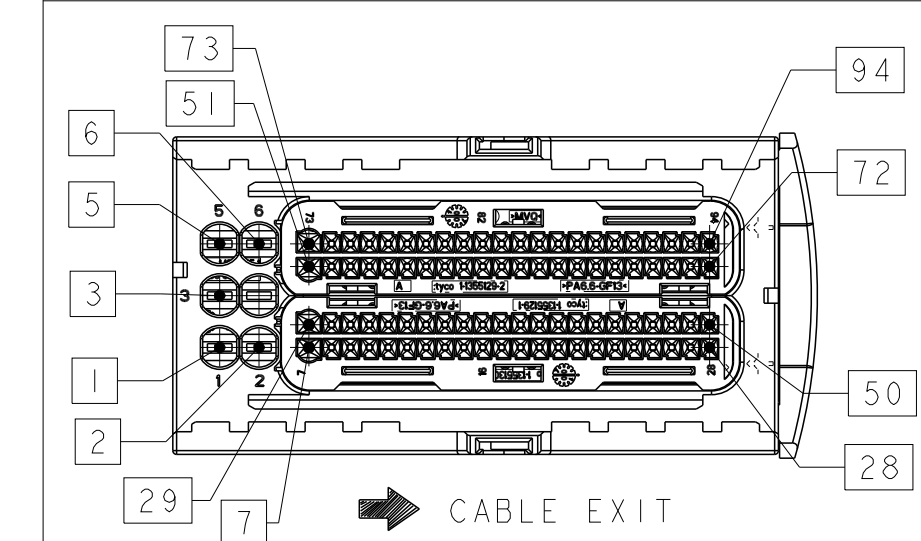

CAVITIES POSITION	
CONTACT P/N	POSITION
968220-1 & 968221-1	8 to 28; 30 to 50; 52 to 72; 74 to 94
1452158-1 & 1241608-1	7, 29, 51, 73
1241394-1 & 1241396-1	1 to 6

QTY.	QTY.	MATERIALS	COLOURS	DESCRIPTION	ITEM
-	1	PA6.6 GF30	YELLOW	C.P.A.	6
1	1	PA6.6 GF13	BLACK	COVER	5
1	1	PA6.6 GF30	BLACK	LEVER	4
1	1	PA6.6 GF30	VIOLET	SECONDARY LOCK 6 POSN.	3
1	1	PA6.6 GF30	VIOLET	SECONDARY LOCK 88 POSN.	2
1	1	PA6.6 GF30/PBT+ASA-GF20 PA6.6 GF13 + GF33 SILICON	BLACK/LIGHT BROWN:HOUSING YELLOW:PERIPHERAL SEAL RED-BROWN:FAMILY SEAL	CARRIER HSG.	1
284743-2 (NOTE 6)	284743-1 (NOTE 5)	PART-NO.			
E	E	REV			

REVISIONS						
P	LTR	DESCRIPTION	DATE	DWN	APVD	
E2		REVISED PER ECO-11-005033	24MAR2011	RK	HMR	
E3		ECR-12-016287	17SEP2012	M.P.	M.G.	
E4		ECR-14-008540	06SEP2014	M.G.	M.G.	

P/N 284743-1 AS SHOWN
FIAT VERSION

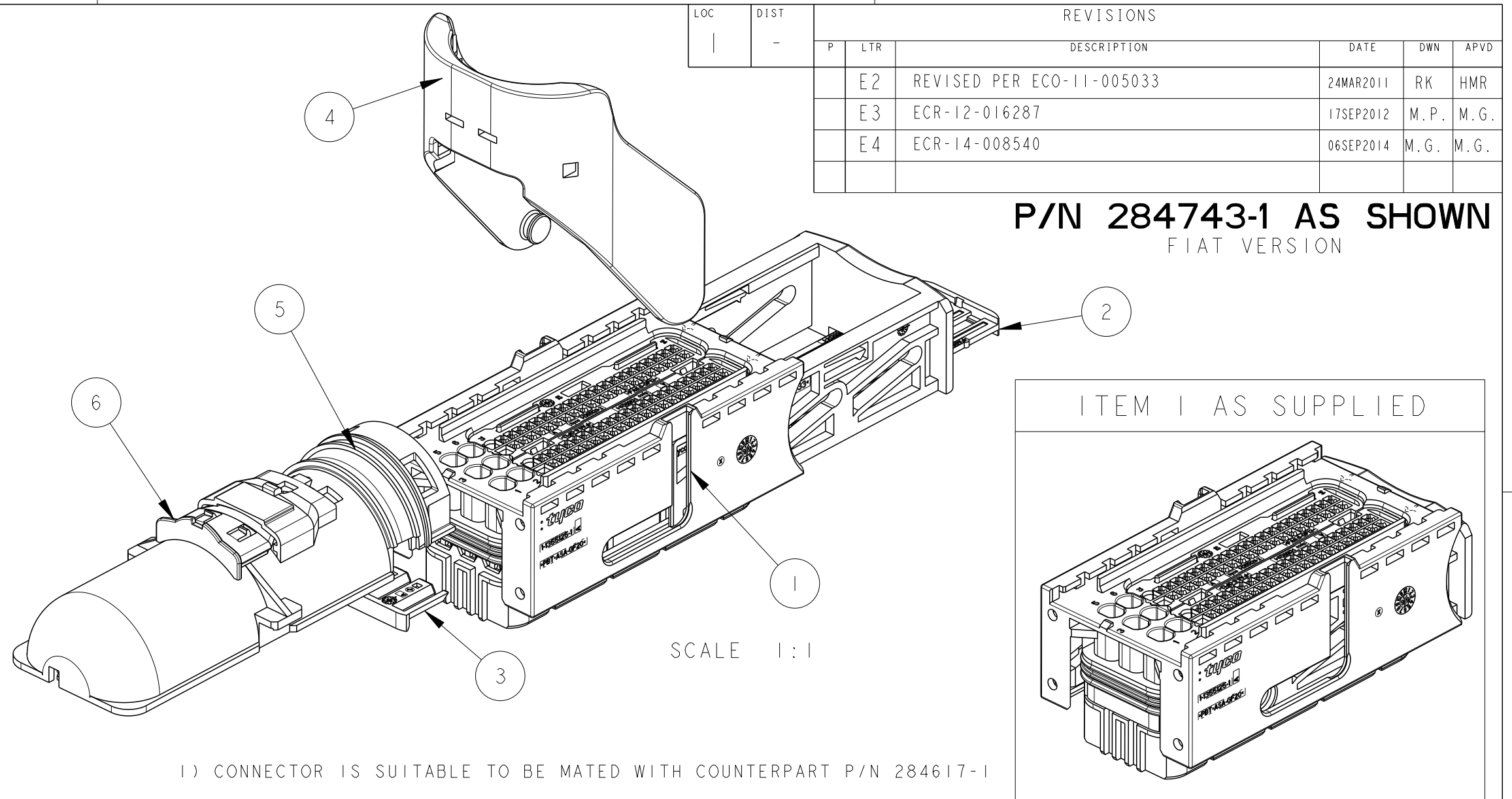

SCALE 1:1

- CONNECTOR IS SUITABLE TO BE MATED WITH COUNTERPART P/N 284617-1
 - CONNECTOR CAVITIES ARE SUITABLE FOR CONTACTS:
 - 0.64 MQS Clean Body contact WSR 0.35±0.50 mm² P/N 1703296-1 (FIAT restricted version)
(Minimum insulation diameter: 1.2 mm; Maximum isolation diameter: 1.6 mm)
 - 0.64 MQS Clean Body contact WSR 0.35 mm² P/N 968220-1
(Minimum insulation diameter 1.2 mm; Maximum isolation diameter: 1.3 mm)
 - 0.64 MQS Clean Body contact WSR 0.75 mm² P/N 1703298-1 (FIAT restricted version)
(Minimum insulation diameter 1.7 mm; Maximum isolation diameter: 1.9 mm)
 - 0.64 MQS Clean Body contact WSR 0.50±0.75 mm² P/N 968221-1
(Minimum insulation diameter 1.4 mm; Maximum isolation diameter: 1.9 mm)
 - 1.5 MQS Clean Body contact WSR 0.50 mm² P/N 1452158-1
(Minimum insulation diameter 1.4 mm; Maximum isolation diameter: 1.6 mm)
 - 1.5 MQS Clean Body contact WSR 0.75±1.50 mm² P/N 1241608-1
(Minimum insulation diameter 1.7 mm; Maximum isolation diameter: 2.4 mm)
 - 2.8K MCP Contacts SWS, WSR 0.35 mm² P/N 1241392-1
(Minimum insulation diameter 1.2 mm; Maximum isolation diameter: 1.3 mm)
 - 2.8K MCP Contacts SWS, WSR 0.5±1.0 mm² P/N 1241394-1
(Minimum insulation diameter 1.4 mm; Maximum isolation diameter: 2.1 mm)
 - 2.8K MCP Contacts SWS, WSR > 1.0±2.5 mm² P/N 1241396-1
(Minimum insulation diameter 2.0 mm; Maximum isolation diameter: 3.0 mm)
- SINGLE WIRE SEAL FOR MCP 2.8K:
 P/N 963294-1 FOR WSR 0.35-1.0 mm²;
 P/N 963293-1 FOR WSR 1.5 mm²;
 P/N 963292-1 FOR WSR 2.5 mm².

- TO CLOSE UNUSED CAVITIES:
 - P/N 284583-1 for MQS Clean Body contacts cavities
 - P/N 1394872-1 for 1.5 mm Clean Body contact cavities
 - P/N 828922-1 for 2.8K MCP contact cavities
- ITEM 2, 3 AND 4 ARE SUPPLIED NOT ASSEMBLED IN THE SAME PACKAGE.
- ITEMS 5 AND 6 ARE SUPPLIED PRE-ASSEMBLED, IN THE SAME PACKAGE.
- ITEMS 5 IS SUPPLIED NOT ASSEMBLED IN THE SAME PACKAGE
ITEM 6 IS NOT SUPPLIED

THIS DRAWING IS A CONTROLLED DOCUMENT.		DWN D. BISETTI 03OCT2001	TE Connectivity	
		CHK O. CANUTO 03OCT2001		
DIMENSIONS: mm	TOLERANCES UNLESS OTHERWISE SPECIFIED:	APVD	NAME CONNECTOR HOUSING, 94 POS. MQS, 1.5 mm Clean body, MCP 2.8 + COVER AND C.P.A. KIT	
	0 PLC ±0.3 1 PLC ±0.3 2 PLC ±0.3 3 PLC ± 4 PLC ±	PRODUCT SPEC 108-20235	SIZE 411-20067	
MATERIAL	FINISH	APPLICATION SPEC	CAGE CODE A200779	
SEE TABLE	SEE TABLE	WEIGHT -	DRAWING NO C-284743	
Customer Drawing		SCALE 1:1	RESTRICTED TO -	
		SHEET 1	REV E4	