

292161-2 Product Details

[Share](#) [Print](#) [Email](#)

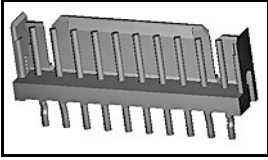

292161-2

TE Internal Number: 292161-2

 Active

[View 3D PDF](#)

2mm AMP CT Connectors

 Always EU RoHS/ELV Compliant
(Statement of Compliance)

Product Highlights:

- Wire-to-Board
- Applies To Printed Circuit Board
- Connector
- Header
- Header Type = Partially Shrouded

[View all Features](#)

Quick Links

- ▶ [Pricing & Availability](#)
- ▶ [Search for Tooling](#)
- ▶ [View Mating Products \(3\)](#)
- ▶ [Product Feature Selector](#)
- ▶ [Contact Us About This Product](#)

[Add to My Part List](#)

[Request Sample](#)

[Find Similar Products](#)

[Buy Product](#)

Documentation & Additional Information

Product Drawings:

- [POST HEADER ASS'Y VERTICAL TYPE \(AMP CT CONNECTOR 2m...](#) (PDF, English)

Catalog Pages/Data Sheets:

- [2.0MM_AMP_CT_CONNECTOR_SERIES_QUICK_REF_GUIDE](#) (PDF, English)

Product Specifications:

- None Available

Application Specifications:

- None Available

Instruction Sheets:

- None Available

CAD Files: (CAD Format & Compression Information)

- [2D Drawing](#) (DXF, Version A)
- [3D Model](#) (IGES, Version A)
- [3D Model](#) (STEP, Version A)

[List all Documents](#)

Additional Product Images:

- [Typical Application](#)

Related Products:

- [Tooling](#)
- [Mating Products \(3\)](#)

Product Features (Please use the Product Drawing for all design activity)

Product Type Features:

- [Product Type](#) = Connector
- Connector Type = Header
- Termination Method to PC Board = Through Hole - Solder
- PCB Mounting Orientation = Vertical
- PCB Mount Alignment = Without
- [PCB Mount Retention](#) = With
- PCB Mount Retention Type = Kinked Leg(s)
- Shrouded = Yes - Partial
- Sealed = No
- UL File Number = E28476
- CSA File Number = LR 7189

Electrical Characteristics:

- Contact - Rated Current (A) = 4

Housing Features:

- Connector Style = Plug
- Centerline (mm [in]) = 2.00 [0.079]
- Housing Color = Natural
- UL Flammability Rating = UL 94V-0

Configuration Features:

- [Number of Positions](#) = 2
- [Number of Rows](#) = 1

Industry Standards:

- [RoHS/ELV Compliance](#) = RoHS compliant, ELV compliant
- [Lead Free Solder Processes](#) = Wave solder capable to 240°C
- RoHS/ELV Compliance History = Always was RoHS compliant

- Operating Voltage Reference = AC/DC, AC, DC
- Operating Voltage (VAC) = 125
- Operating Voltage (VDC) = 125

Termination Features:

- Wire/Cable Size (AWG) = 22 - 28
- Tail Orientation = In-line
- Tail Length (mm [in]) = 3.2 [0.126]

Dimensions:

- Mating Post Length (mm [in]) = 4.50 [0.177]
- PCB Thickness, Recommended (mm [in]) = 0.80 - 1.60 [0.031 - 0.063]
- Length (X-Axis) (mm [in]) = 5.80 [0.228]
- Width (Z-Axis) (mm [in]) = 3.60 [0.141]
- Profile Height (Y-Axis) (mm [in]) = 6.80 [0.267]

Body Features:

- Header Type = Partially Shrouded
- Mating Retention = Without

Contact Features:

- Contact Type = Pin
- Contact Plating, Mating Area, Material = Tin
- Contact Plating, Mating Area, Thickness (μm [μin]) = 1 [39.37]
- Contact Plating, Termination Area, Material = Tin
- Contact Plating, Termination Area, Thickness (μm [μin]) = 1 [40]

- Agency/Standard = CSA, UL

Environmental:

- Operating Temperature ($^{\circ}\text{C}$ [$^{\circ}\text{F}$]) = -40 - +105 [-40 - +221]

Conditions for Usage:

- Applies To = Printed Circuit Board

Operation/Application:

- Application Use = Wire-to-Board
- Contact Transmits (Typical Application) = Signal (Data)
- Pick and Place Cover = Without

Packaging Features:

- Packaging Method = Bag, Box

Other:

- Brand = AMP

Corporate Information

- [About TE](#)
- [Investors](#)
- [News Room](#)
- [Supplier Portal](#)
- [Careers](#)
- [Terms & Conditions](#)
- [Privacy Policy](#)

Quick Links

- [Distributor Inventory](#)
- [Product Cross Reference](#)
- [Documents & Drawings](#)
- [Product Compliance Support Center](#)
- [Site Map](#)

Customer Support

- [Email or Chat With Us](#)
- [Find a Phone Number](#)
- [Knowledge Base](#)
- [Manage Your Account](#)

Keep Me Informed



THIS DRAWING IS UNPUBLISHED. RELEASED FOR PUBLICATION
 © COPYRIGHT - By - ALL RIGHTS RESERVED.

LOC FB	DIST 00	REVISIONS		
P	LTR	DESCRIPTION	DATE	DWN
P		REVISED PER ECO-11-005033	24MAR11	RK
				APVD HMR

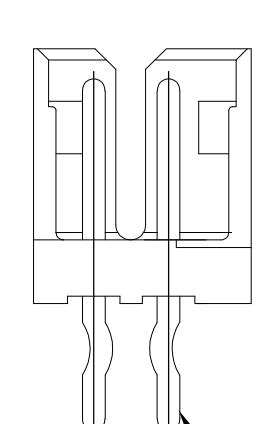
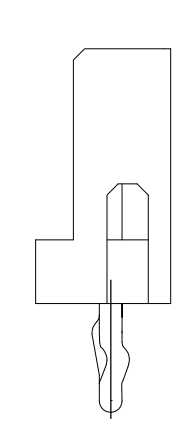
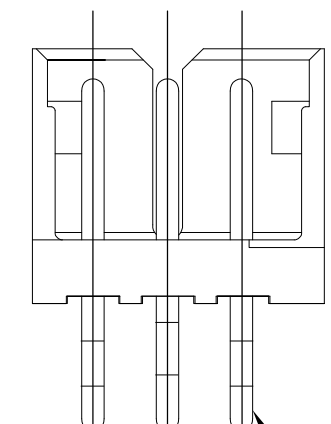
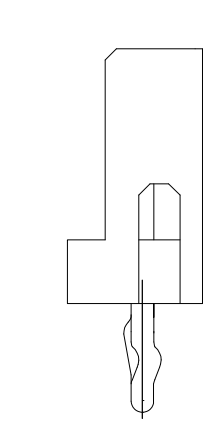
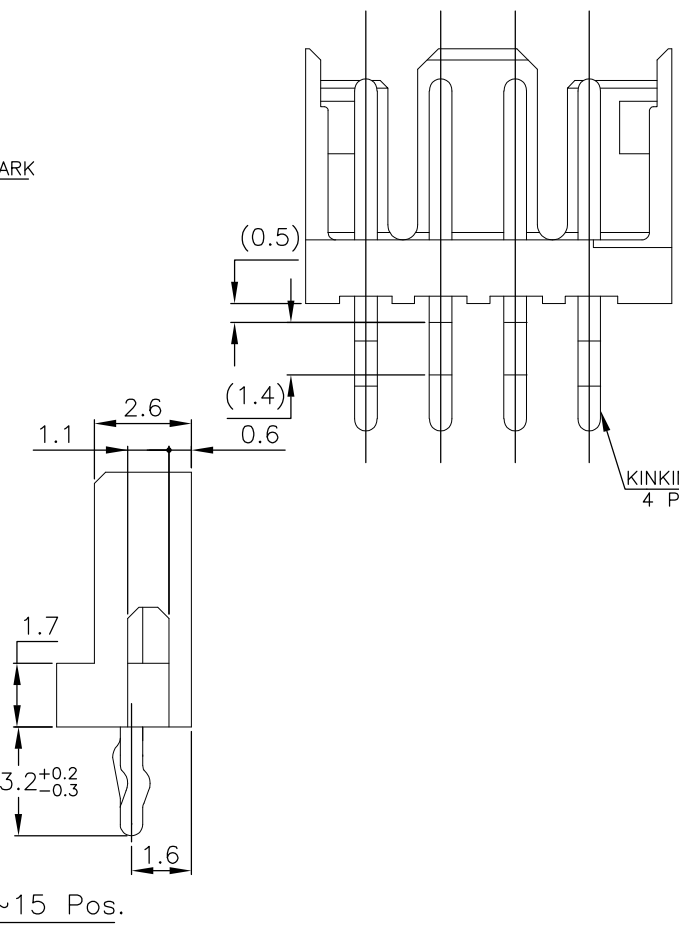
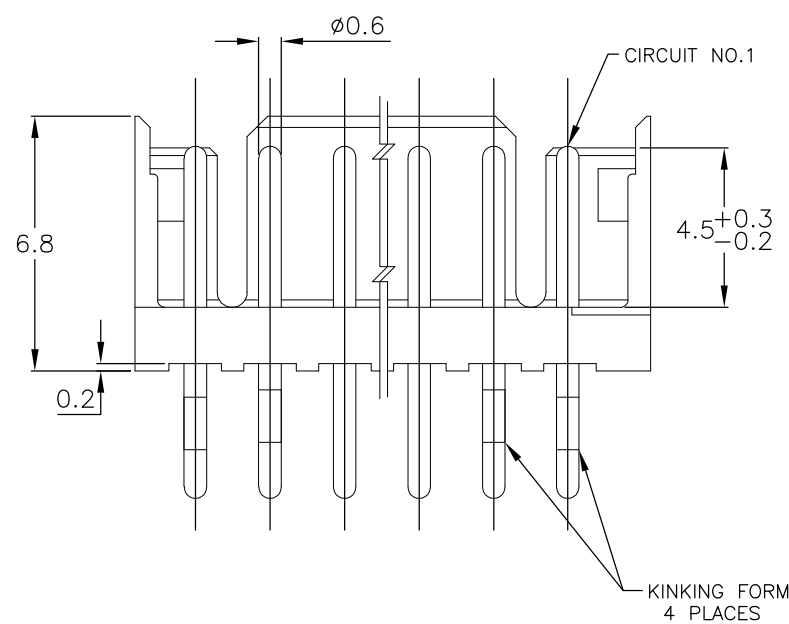
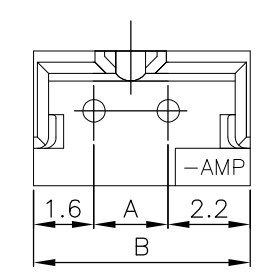
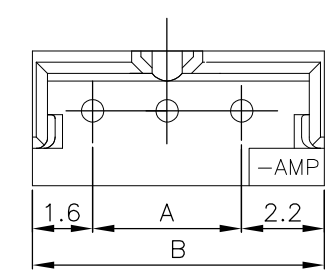
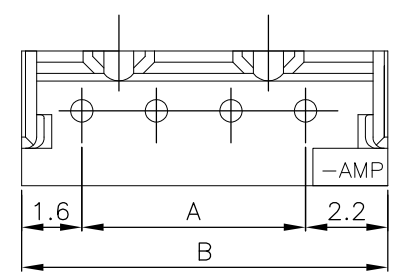
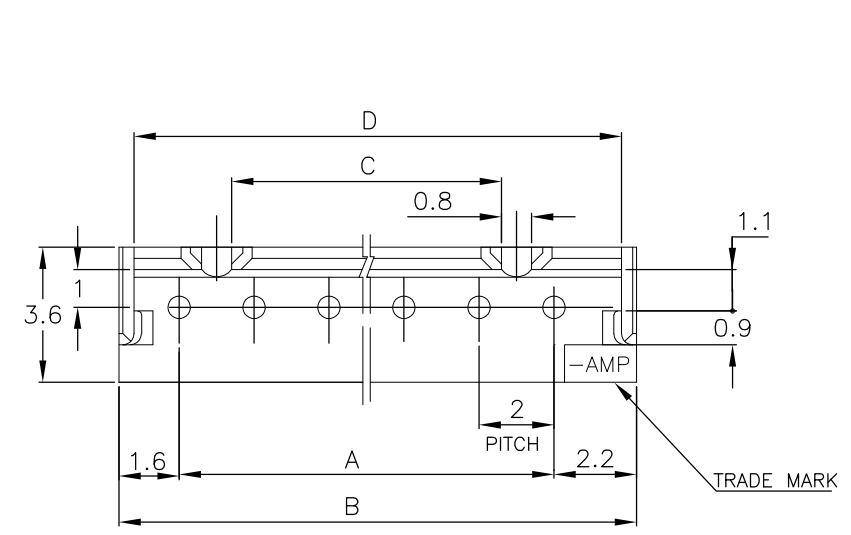

4 POS.

3 POS.

2 POS.

5~15 Pos.

NOTES:

- 1.MATERIAL: HOUSING - NYLON 66 (UL94V-0)
POST - TIN BRASS
- 2.APPLICABLE RECEPTACLE P/N 173977

	7-292161-5	5-292161-5	3-292161-5	1-292161-5	15	28	31.8	25.2	31.0
	7- ↑ -4	5- ↑ -4	3- ↑ -4	1- ↑ -4	14	26	29.8	23.2	29.0
	7- -3	5- -3	3- -3	1- -3	13	24	27.8	21.2	27.0
9-292161-2	7- -2	5- -2	3- -2	1- -2	12	22	25.8	19.2	25.0
9- ↑ -1	7- -1	5- -1	3- -1	1- -1	11	20	23.8	17.2	23.0
9- -0	7- -0	5- -0	3- -0	1- -0	10	18	21.8	15.2	21.0
8- -9	6- -9	4- -9	2- -9		9	16	19.8	13.2	19.0
8- -8	6- -8	4- -8	2- -8		8	14	17.8	11.2	17.0
8- -7	6- -7	4- -7	2- -7		7	12	15.8	9.2	15.0
8- -6	6- -6	4- -6	2- -6		6	10	13.8	7.2	13.0
8- -5	6- -5	4- -5	2- -5		5	8	11.8	5.2	11.0
8- -4	6- -4	4- -4	2- -4		4	6	9.8	3.2	9.0
8- ↓ -3	6- ↓ -3	4- ↓ -3	2- ↓ -3		3	4	7.8	-	7.0
8-292161-2	6-292161-2	4-292161-2	2-292161-2	292161-2	2	2	5.8	-	5.0
RED	BLACK	YELLOW	BLUE	NATURAL	Pos.	A	B	C	D

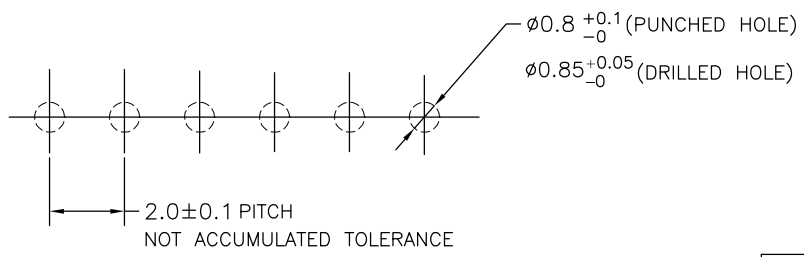

RECOMMENDABLE PCB LAYOUT
 (PCB THK:0.8-1.6)

TOLERANCES UNLESS OTHERWISE SPECIFIED:

10 > *	:	±0.2
30 > * > 10	:	±0.25
100 > * > 30	:	±0.3
ANGLE	:	±3°

THIS DRAWING IS A CONTROLLED DOCUMENT.

DIMENSIONS:	TOLERANCES UNLESS OTHERWISE SPECIFIED:
mm	0 PLC ± -
	1 PLC ± -
	2 PLC ± -
	3 PLC ± -
	4 PLC ± -
	ANGLES ± -
MATERIAL	FINISH
SEE NOTE	SEE NOTE

DWN S.XU	31JAN03	 TE Connectivity
CHK S.YAO	31JAN03	
APVD T. SASAKI	31JAN03	
PRODUCT SPEC 108-60016		
APPLICATION SPEC		NAME POST HEADER ASS'Y VERTICAL TYPE (AMP CT CONNECTOR 2mm PITCH)
WEIGHT		SIZE A3
CUSTOMER DRAWING		CAGE CODE 00779
		DRAWING NO C-292161
		RESTRICTED TO
	SCALE 5:1	SHEET 1 OF 1
		REV P