

APPLICABLE FPC
 RECOMMENDED DIMENSION
 (THICKNESS: 0.3 \pm 0.05)

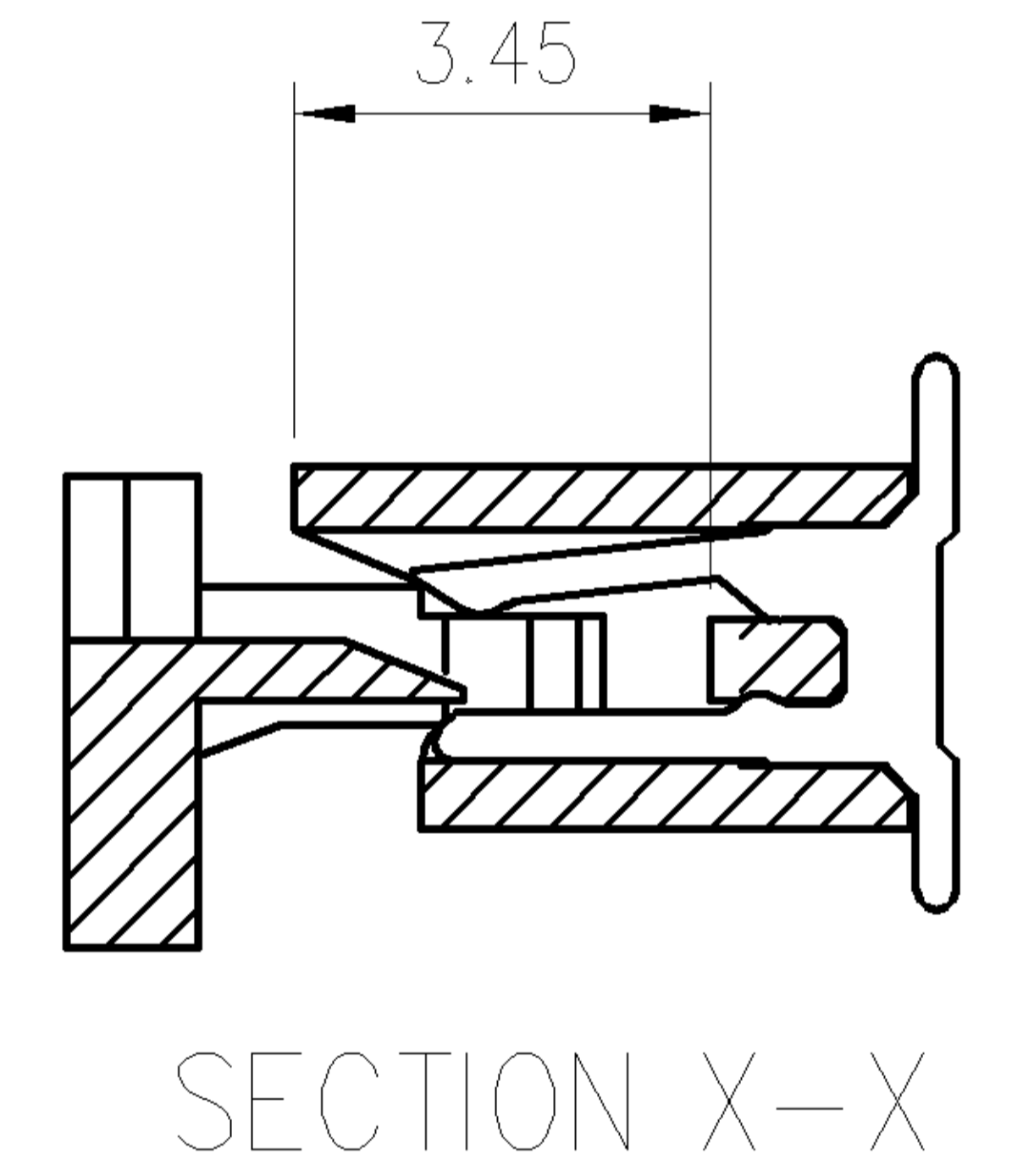
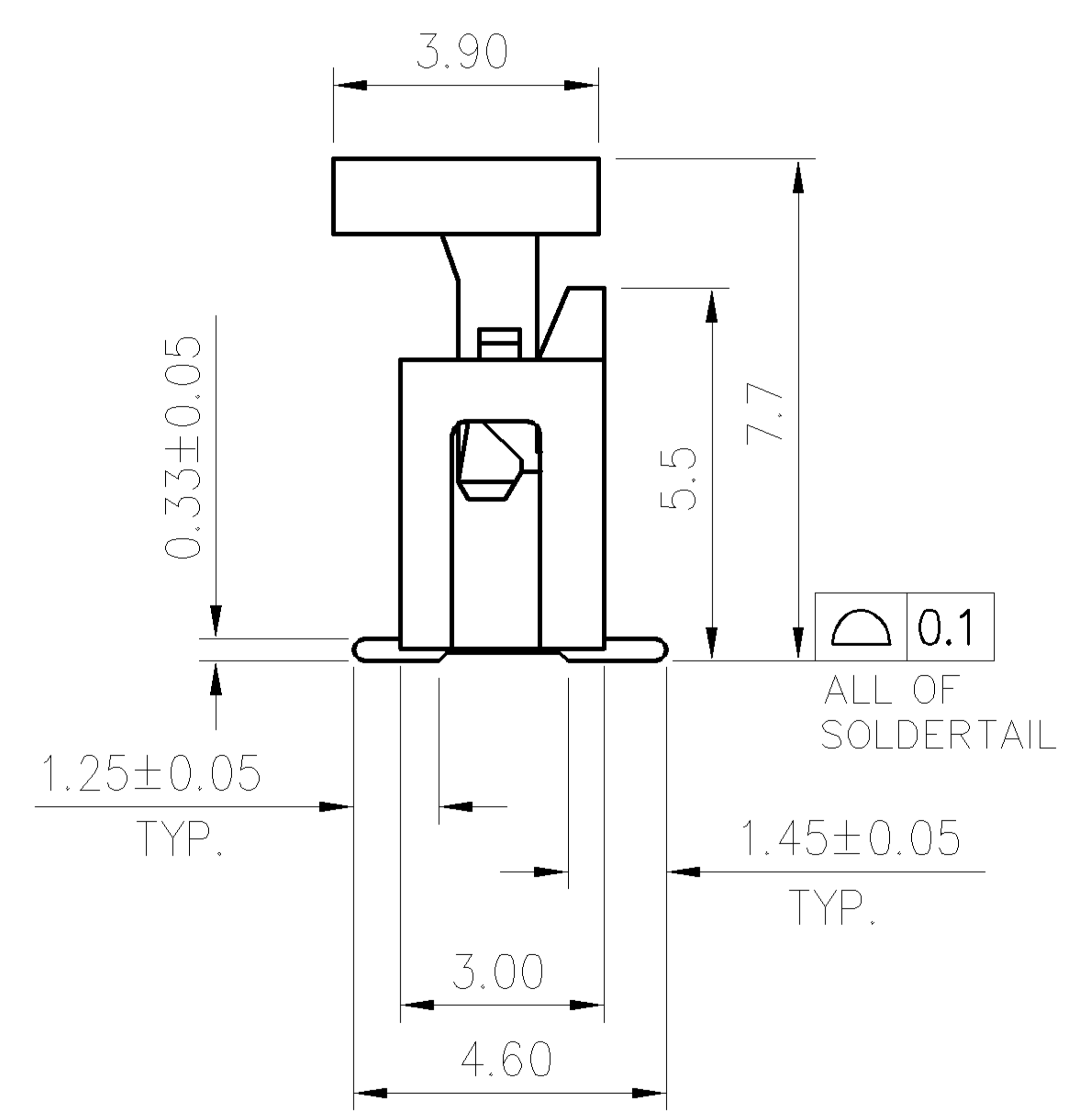
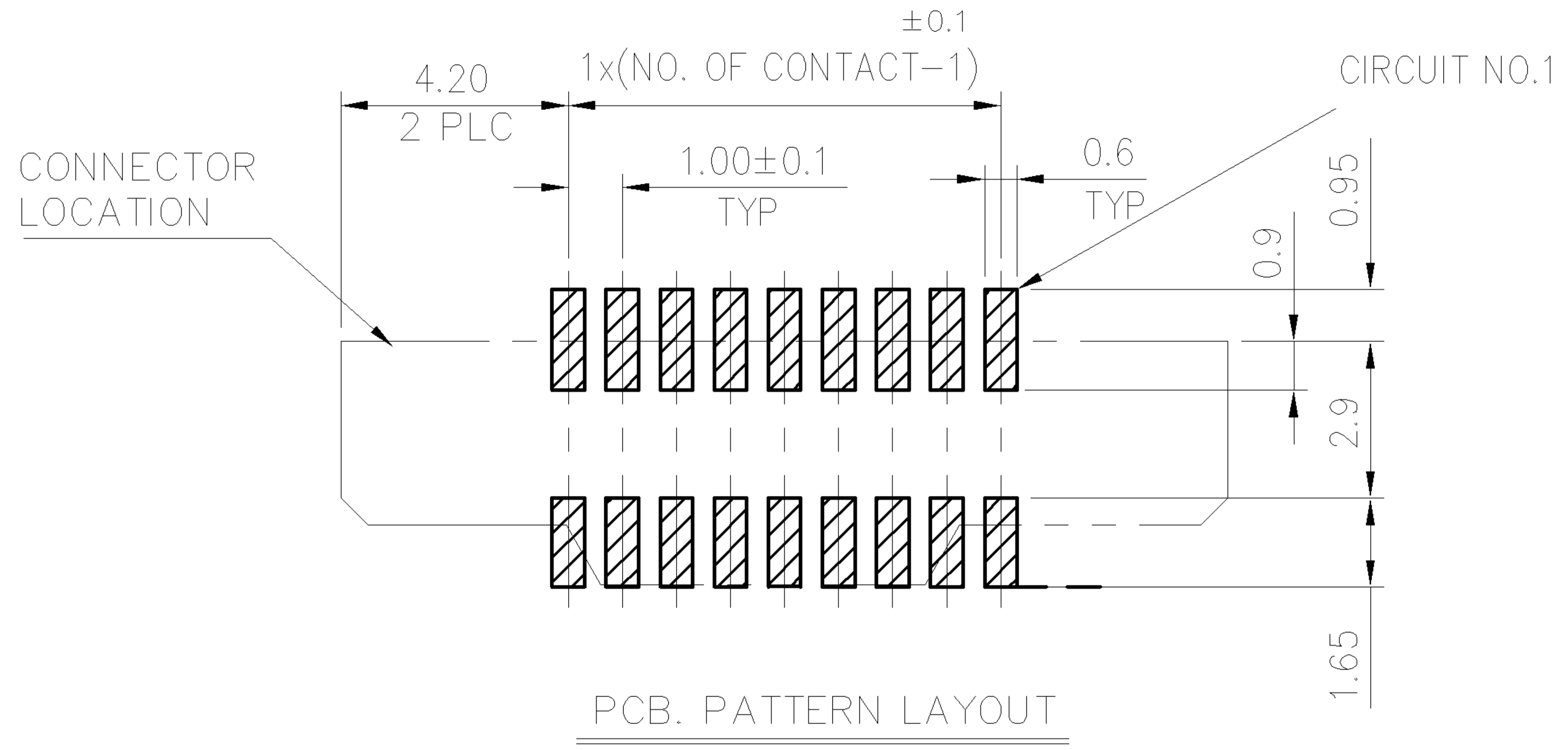

- NOTES:
 1. MATERIAL:
 1.1 HOUSING: THERMOPLASTIC (PA9T)
 UL94 V-0, COLOR: BLACK.
 1.2 ACTUATOR: THERMOPLASTIC (PA9T)
 UL94 V-0, COLOR: BLACK.
 1.3 CONTACTS: PHOSPHOR BRONZE
 2. FINISH:
 2.1 CONTACT:
 GOLD FLASH PLATING OVERALL.
 1.27 μ m (50 μ) MIN. NICKEL UNDERPLATING OVERALL.
 3. REFLOW SOLDER CAPABLE TO 260°C PER TEC-109-201,
 CONDITION B.
 \triangle WITHOUT DATE CODE FOR 8 POSITION UNDER.

37	41.40	45.6	39.0	40	4-1734248-0
36	40.40	44.6	38.0	39	3-1734248-9
35	39.40	43.6	37.0	38	3-1734248-8
34	38.40	42.6	36.0	37	3-1734248-7
33	37.40	41.6	35.0	36	3-1734248-6
32	36.40	40.6	34.0	35	3-1734248-5
31	35.40	39.6	33.0	34	3-1734248-4
30	34.40	38.6	32.0	33	3-1734248-3
29	33.40	37.6	31.0	32	3-1734248-2
28	32.40	36.6	30.0	31	3-1734248-1
27	31.40	35.6	29.0	30	3-1734248-0
26	30.40	34.6	28.0	29	2-1734248-9
25	29.40	33.6	27.0	28	2-1734248-8
24	28.40	32.6	26.0	27	2-1734248-7
23	27.40	31.6	25.0	26	2-1734248-6
22	26.40	30.6	24.0	25	2-1734248-5
21	25.40	29.6	23.0	24	2-1734248-4
20	24.40	28.6	22.0	23	2-1734248-3
19	23.40	27.6	21.0	22	2-1734248-2
18	22.40	26.6	20.0	21	2-1734248-1
17	21.40	25.6	19.0	20	2-1734248-0
16	20.40	24.6	18.0	19	1-1734248-9
15	19.40	23.6	17.0	18	1-1734248-8
14	18.40	22.6	16.0	17	1-1734248-7
13	17.40	21.6	15.0	16	1-1734248-6
12	16.40	20.6	14.0	15	1-1734248-5
11	15.40	19.6	13.0	14	1-1734248-4
10	14.40	18.6	12.0	13	1-1734248-3
9	13.40	17.6	11.0	12	1-1734248-2
8	12.40	16.6	10.0	11	1-1734248-1
7	11.40	15.6	9.0	10	1-1734248-0
6	10.40	14.6	8.0	9	1734248-9
5	9.40	13.6	7.0	8	1734248-8
4	8.40	12.6	6.0	7	1734248-7
3	7.40	11.6	5.0	6	1734248-6
2	6.40	10.6	4.0	5	1734248-5
2	5.40	9.6	3.0	4	1734248-4
2	4.40	8.6	2.0	3	1734248-3
DIM D	DIM C	DIM B	DIM A	POS.	PART NUMBER

C1	REVISED PER ECO-11-005301	RK HMR	02APR11
LTR	REVISION RECORD	ECO	DWN CHK DATE

TOLERANCES UNLESS OTHERWISE SPECIFIED: 0 PLC \pm 1 PLC ± 0.3 2 PLC ± 0.2 3 PLC \pm ANGLES $\pm 3^\circ$	DWN H. HUANG 30-MAR-2007	STE TE Connectivity			
MATERIAL SEE NOTE	CHK S. HOU 30-MAR-2007	NAME 1.0 MM FPC, ZIF VERTICAL, SMT TYPE.			
FINISH SEE NOTE	APVD W.J. KE 30-MAR-2007	PRODUCT SPEC 108-57080			
	QUALIFICATION TEST REPORT 501-57098	LOC DW	SIZE A ₃	DRAWING NO C-1734248	REV C1
	WEIGHT --	SCALE --		SHEET 1 OF 2	

NUMBER
C-1734248

3RD ANGLE PROJECTION

METRIC

DIMENSIONS IN MILLIMETERS. DO NOT SCALE PRINT.

PRINT DIST
DW

- NOTES:
- MATERIAL :
 - EMBOSSED CARRIER: PS
 - COVER TAPE: PS
 - SHIPPING CARTON: CORRUGATED FIBER
 - DIMENSION :
 - REEL: W=DIM C
 - SHIPPING BOX: L=350, W=350, H=350
 - QUANTITY: PRIMARY PACKING: 1000 PCS/REEL
 - PEELING RESISTANCE: 10.2gf~71.4gf.
 - PEELING SPEED: 300mm/minutes.

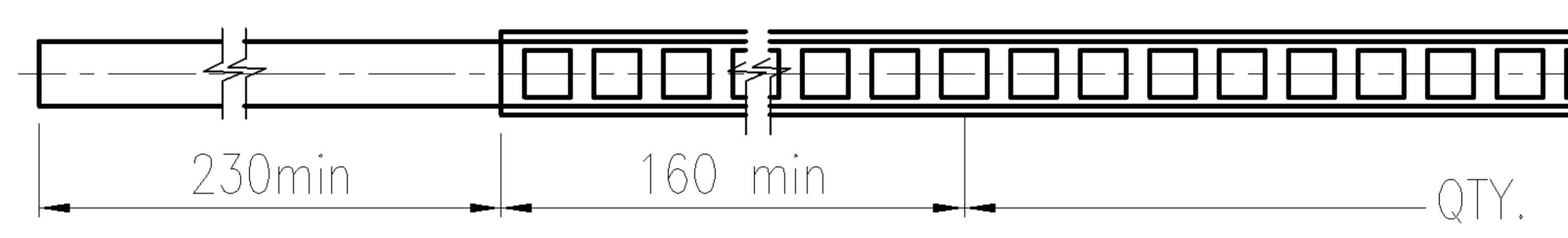
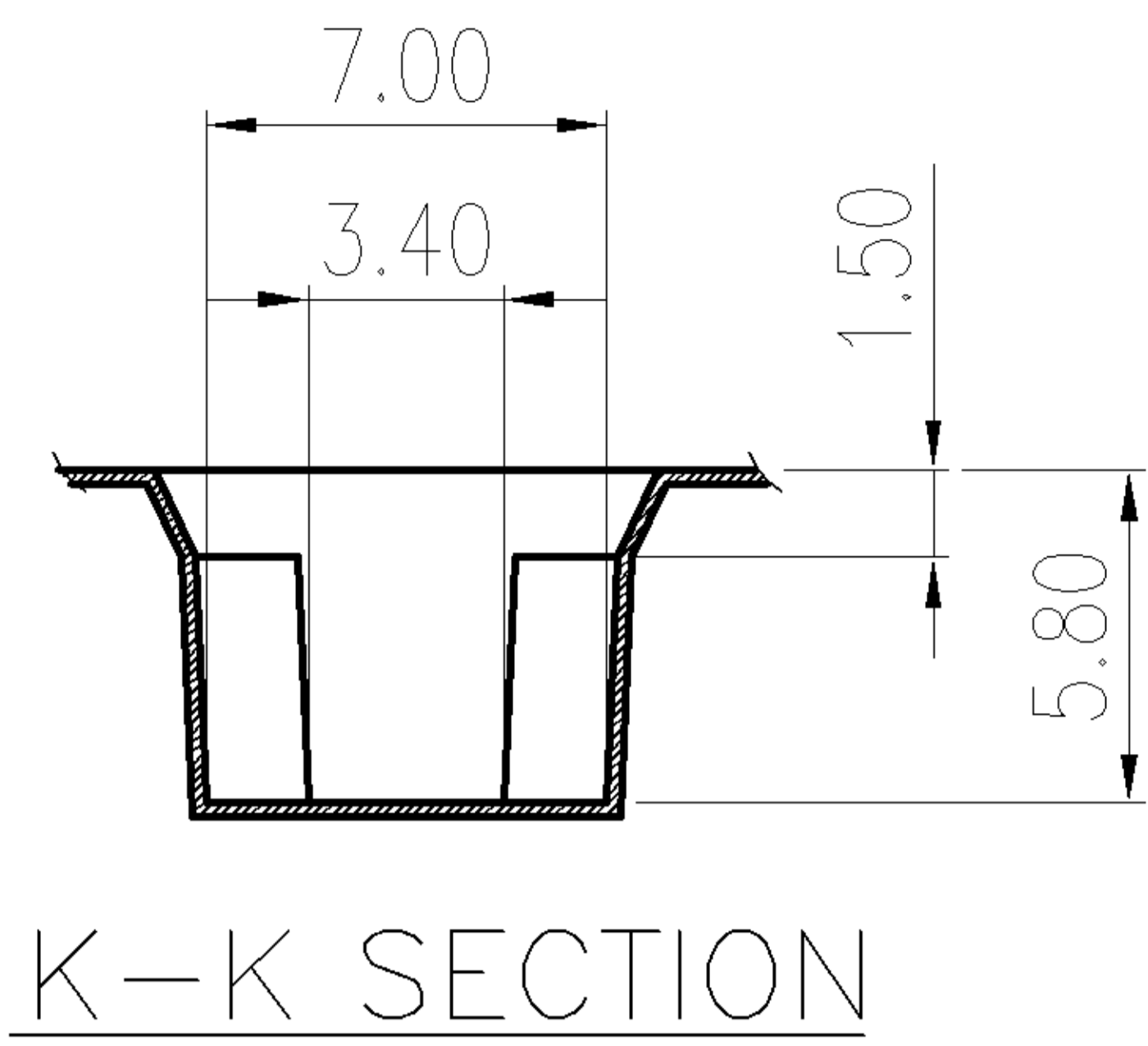

PULL OUT DIRECTION

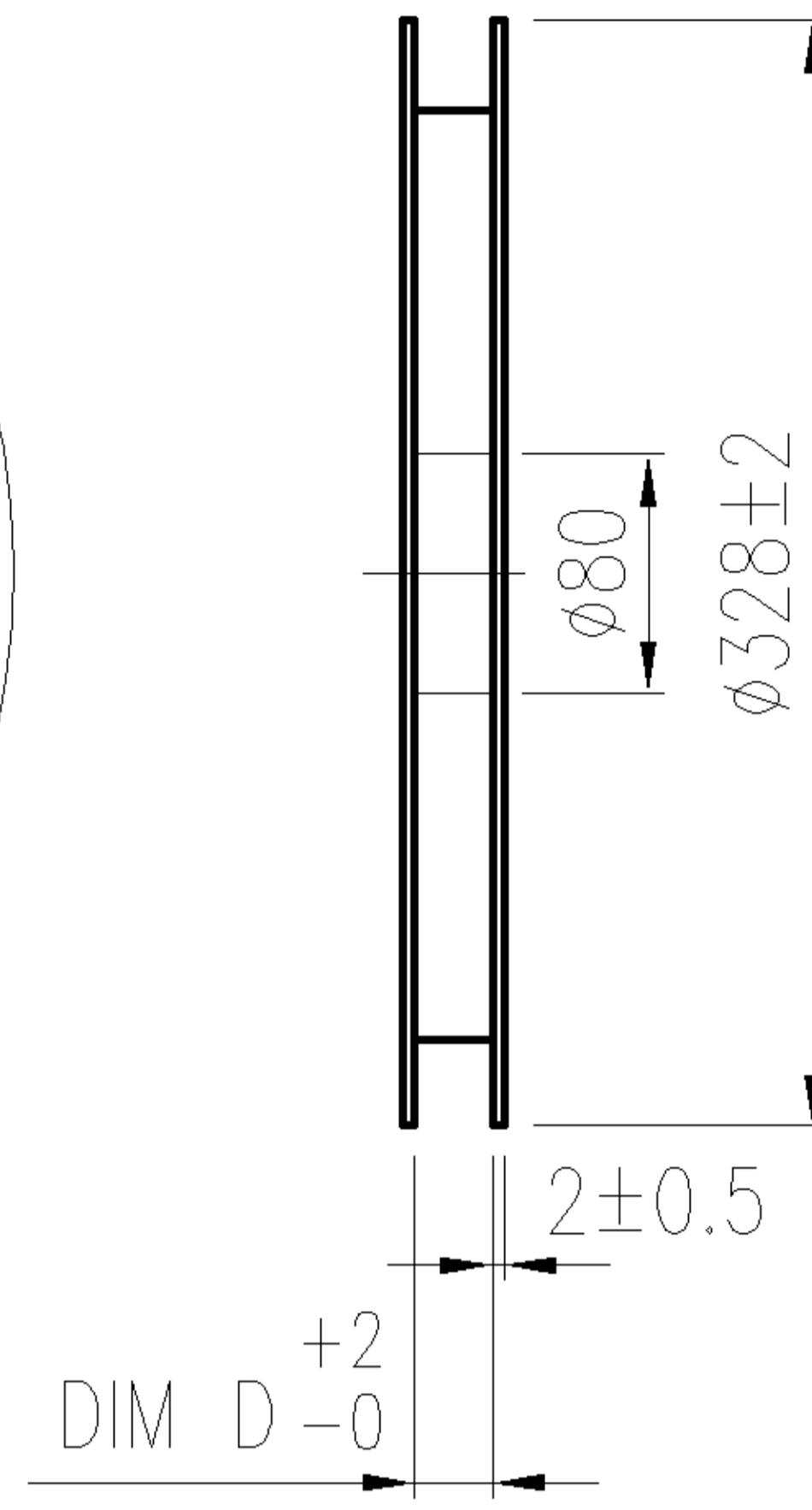
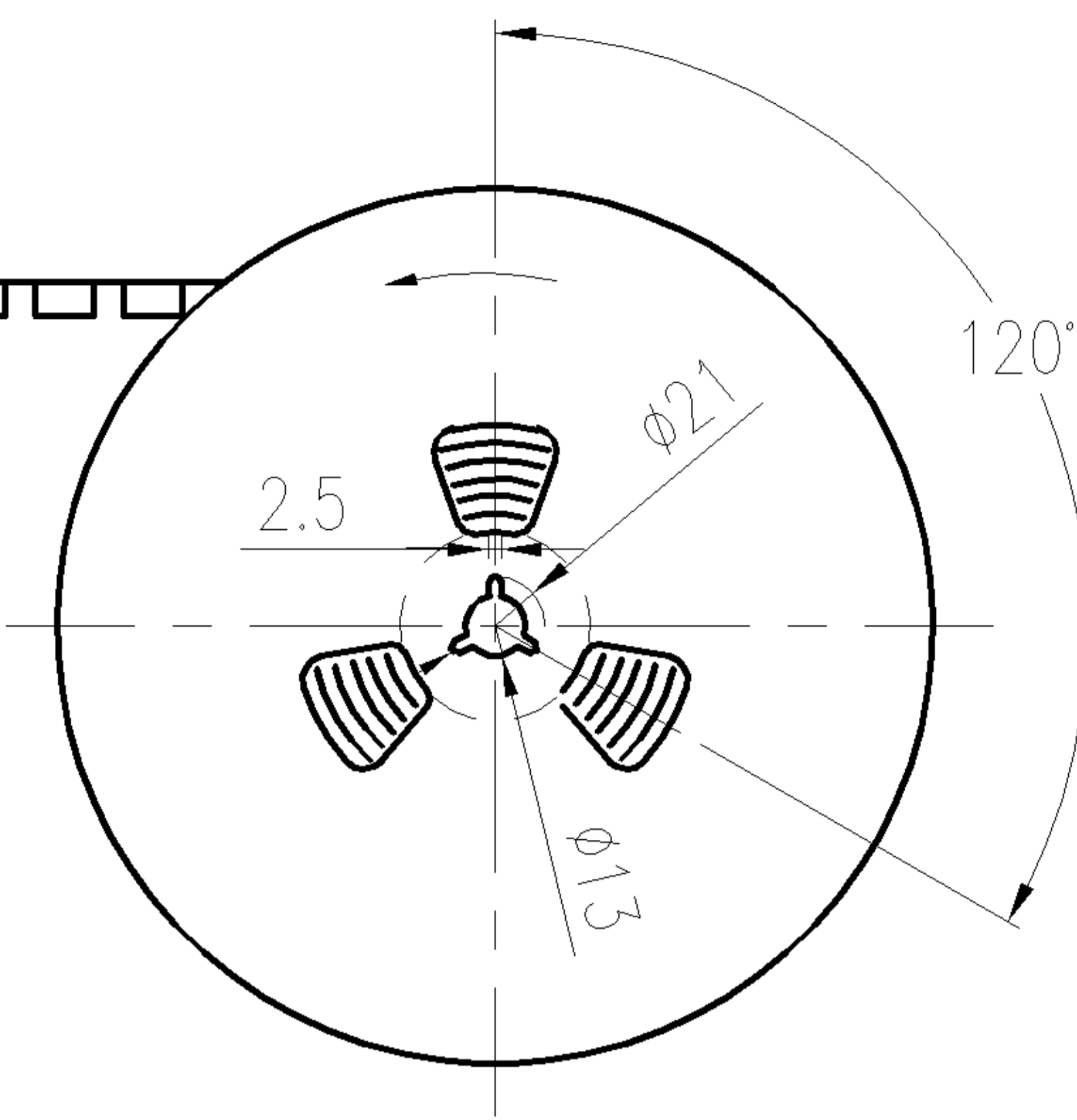

USER DIRECTION OF UNREELING

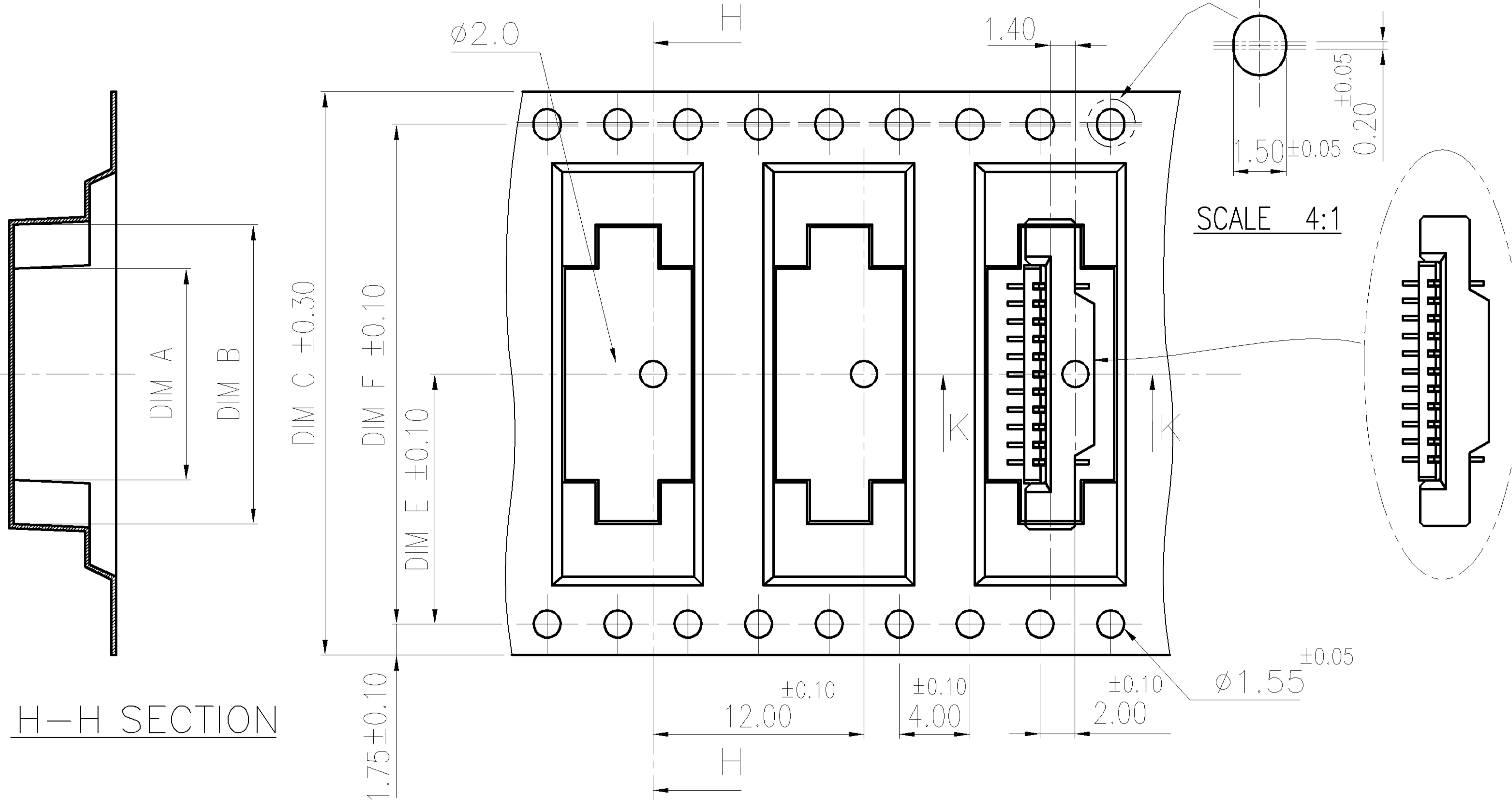

H-H SECTION

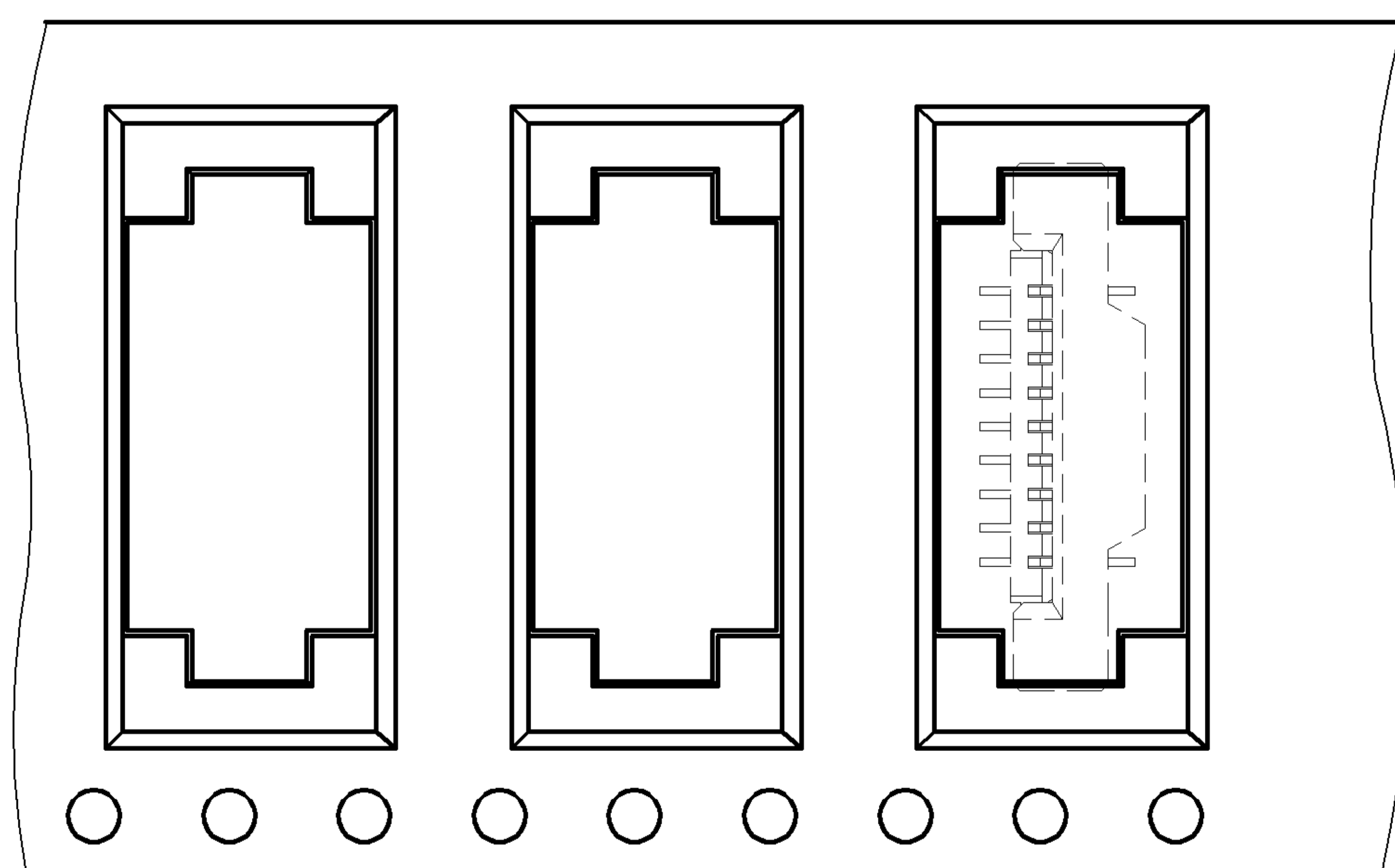

FOR 3 TO 10 POS.

USER DIRECTION OF UNREELING

REELS/BOX	DIM F	DIM E	DIM D	DIM C	DIM B	DIM A	G/W (kg)	N/W (kg)	POS.	PART NUMBER
4	68.4	34.2	72.4	72	46	41	8.70	5.50	40	4-1734248-0
					45	40	8.57	5.37	39	3-1734248-9
					44	39	8.45	5.25	38	3-1734248-8
					43	38	11.60	7.68	37	3-1734248-7
					42	37	11.40	7.48	36	3-1734248-6
					41	36	11.21	7.29	35	3-1734248-5
					40	35	11.02	7.10	34	3-1734248-4
					39	34	10.83	6.91	33	3-1734248-3
					38	33	10.63	6.71	32	3-1734248-2
					37	32	10.44	6.52	31	3-1734248-1
					36	31	10.25	6.33	30	3-1734248-0
					35	30	10.06	6.14	29	2-1734248-9
					34	29	9.86	5.94	28	2-1734248-8
					33	28	9.67	5.75	27	2-1734248-7
					32	27	9.00	5.56	26	2-1734248-6
					31	26	8.80	5.36	25	2-1734248-5
					30	25	8.61	5.17	24	2-1734248-4
					29	24	8.42	4.98	23	2-1734248-3
					28	23	8.23	4.79	22	2-1734248-2
					27	22	8.03	4.59	21	2-1734248-1
					26	21	7.84	4.40	20	2-1734248-0
					25	20	7.65	4.21	19	1-1734248-9
					24	19	7.46	4.02	18	1-1734248-8
					23	18	7.26	3.82	17	1-1734248-7
					22	17	7.07	3.63	16	1-1734248-6
					21	16	9.20	5.16	15	1-1734248-5
					20	15	8.91	4.87	14	1-1734248-4
					19	14	8.62	4.58	13	1-1734248-3
					18	13	8.33	4.29	12	1-1734248-2
					17	12	8.04	4.00	11	1-1734248-1
					16	11	7.73	4.13	10	1-1734248-0
					15	10	7.41	3.81	9	1734248-9
					14	9	7.08	3.48	8	1734248-8
					13	8	6.76	3.16	7	1734248-7
					12	7	6.44	2.84	6	1734248-6
					11	6	6.12	2.52	5	1734248-5
					10	5	5.80	2.20	4	1734248-4
					9	4	5.48	1.88	3	1734248-3

TOLERANCES UNLESS OTHERWISE SPECIFIED: 0 PLC ± 1 PLC ±0.3 2 PLC ±0.2 3 PLC ± ANGLES ±3°		DWN H. HUANG 30-MAR-2007	TE Connectivity	
MATERIAL		CHK S. HOU 30-MAR-2007	NAME	
FINISH		APVD W.J. KE 30-MAR-2007	1.0 MM FPC, ZIF VERTICAL, SMT TYPE.	
WEIGHT		PRODUCT SPEC	LOC DW	SIZE A ₃
LTR		QUALIFICATION TEST REPORT	DRAWING NO C-1734248	REV C1
REVISION RECORD		SCALE	SHEET	
ECO		--		2 OF 2
DWN CHK DATE		CUSTOMER DRAWING		