

THIS DRAWING IS UNPUBLISHED. RELEASED FOR PUBLICATION
 © COPYRIGHT - By - ALL RIGHTS RESERVED.

LOC	DIST	REVISIONS					
G	14	P	LTR	DESCRIPTION	DATE	DWN	APVD
		J2		REVISED PER ECO-15-006978	08JUN2015	NK	MM

PART NUMBER	PACKAGE TYPE	QTY	
8-320383-3	LOOSE PIECE, BOX	25	4

AMP WIRE RANGE	E13288 Listed
2 AWG SOLID OR STRANDED	2 AWG STRANDED
LR7189 Certified	MILITARY P/N AND CLASS
2 AWG SOLID OR STRANDED	MS 20659-113 CLASS 2 6

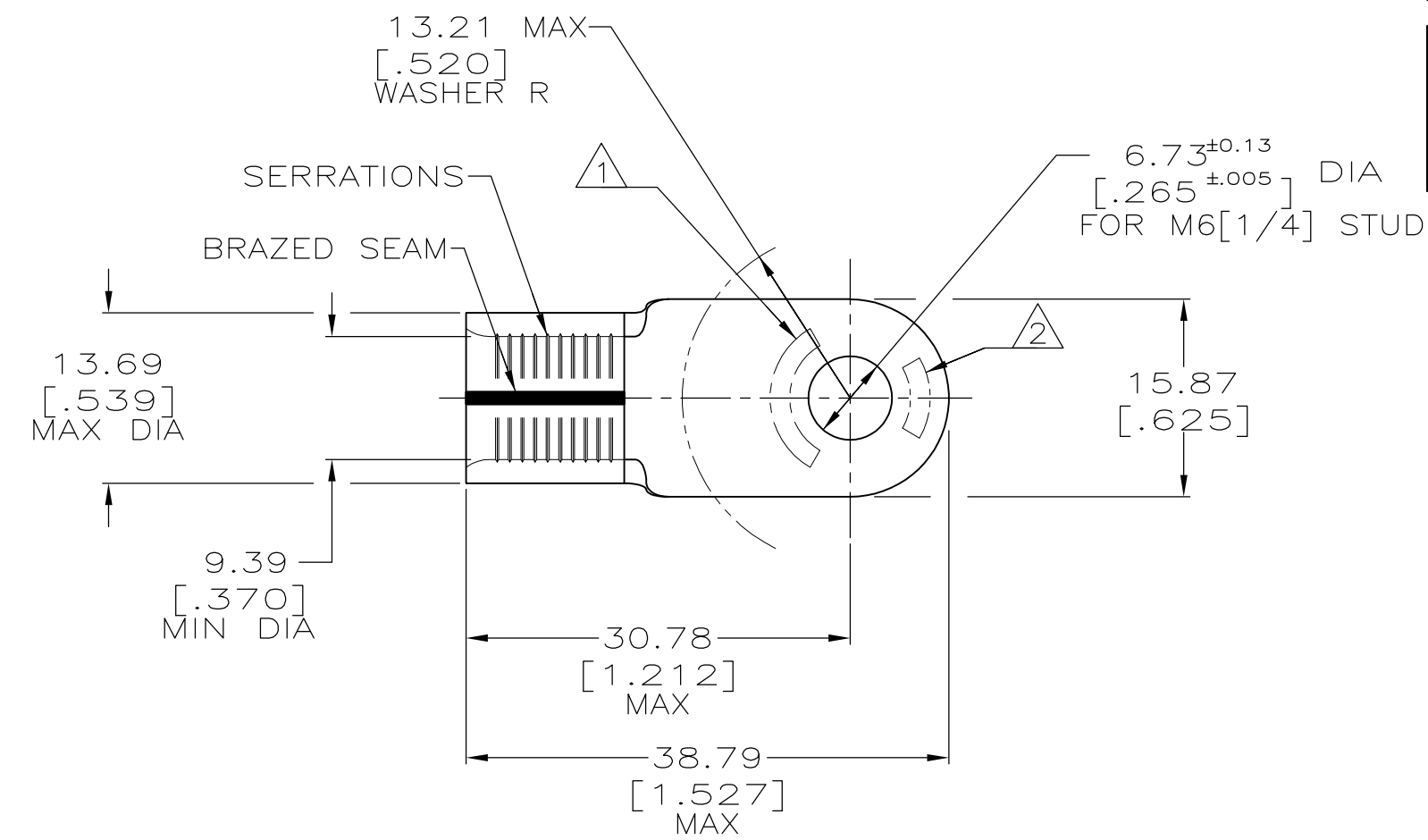

- 1 STAMP AMP 2W* APPROX AS SHOWN.
- 2 STAMP 60-75 APPROX AS SHOWN.
- 3 MATERIAL THK: 1.78±0.08[.070±.003].
- 4 TIN PL 0.00254[.000100] MIN THK PER ASTM B545.
- 5 GOLD PL 0.00127[.000050] MIN THK PER MIL-G-45204 OVER NICKEL PL 0.00076[.000030] MIN THK PER QQ-N-290.

260°C[500°F] MAX	5	2-320383-1
170°C[338°F] MAX	4	320383
TEMPERATURE RATING	FINISH	PART NO

AMP INCORPORATED CUSTOMER SERVICE SYSTEMS		MAX RECOMMENDED OPERATING TEMPERATURE: SEE TABLE
FOR ADDITIONAL PRODUCT INFORMATION OR COPIES OF DRAWINGS AND TECHNICAL DOCUMENTS	PRODUCT INFORMATION CENTER 1-800-522-6752	VOLTAGE RATING: NOT APPLICABLE
FOR APPLICATION TOOLING INFORMATION	TOOLING ASSISTANCE CENTER 1-800-722-1111	WIRE CROSS SECTIONAL AREA RANGE: 26.7-42.4mm² [52,600-83,700] CIR MILS SOLID OR STRANDED
FOR ORDER ENTRY	1-800-526-5142	

THIS DRAWING IS A CONTROLLED DOCUMENT.	
DIMENSIONS: mm [INCHES]	TOLERANCES UNLESS OTHERWISE SPECIFIED:
	0 PLC ± - 1 PLC ± - 2 PLC ± 0.20[.008] 3 PLC ± - 4 PLC ± - ANGLES ± -
MATERIAL COPPER PER ASTM B-152 ANNEALED	FINISH SEE TABLE

DWN DK SCHRUM 5/24/93	TE Connectivity		
CHK RD HEIM 1/27/94	NAME TERMINAL, RING TONGUE, SOLISTRAND™		
APVD RE ROSER 1/27/94	SIZE A3	CAGE CODE 00779	DRAWING NO C-320383
PRODUCT SPEC -	RESTRICTED TO -		
APPLICATION SPEC -	CUSTOMER DRAWING	SCALE 2:1	SHEET 1 OF 1
WEIGHT -	REV J2		