

Distributed by:

JAMECO[®]
ELECTRONICS

www.Jameco.com ♦ 1-800-831-4242

The content and copyrights of the attached
material are the property of its owner.

Jameco Part Number 751373

THIS DRAWING IS UNPUBLISHED. RELEASED FOR PUBLICATION
 © COPYRIGHT BY TYCO ELECTRONICS CORPORATION. ALL RIGHTS RESERVED.

LOC	DIST	REVISIONS					
		P	LTR	DESCRIPTION	DATE	DWN	APVD
G	14	E		REV PER 0G3A-0863-04	29OCT04	JR	MS

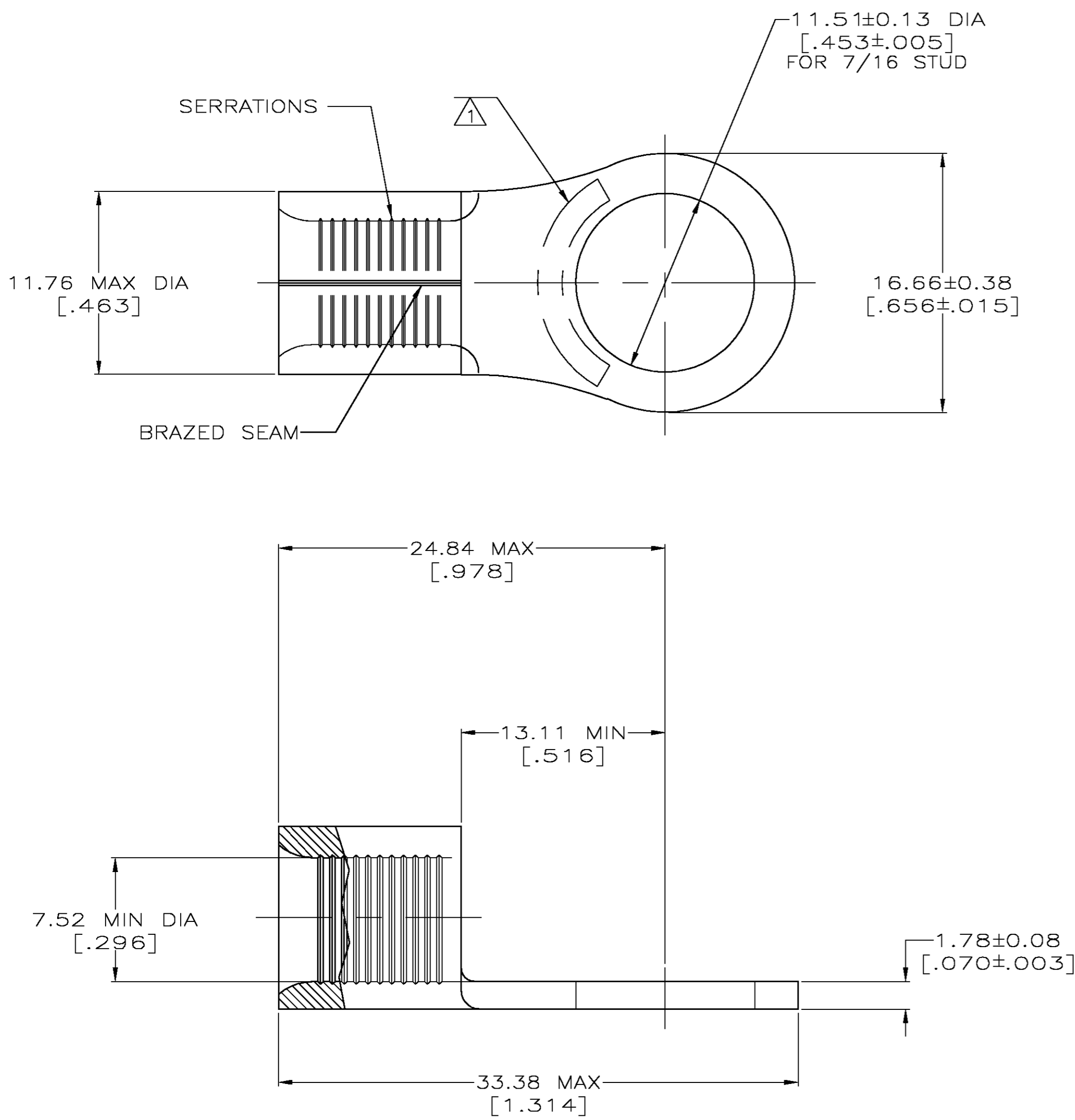

AMP WIRE RANGE	Listed FILE E13288	LR7189 Certified
4 AWG SOLID OR STRANDED	4 AWG STRANDED	4 AWG SOLID OR STRANDED

- ① STAMP AMP 4* APPROX AS SHOWN
- ② TIN PLATE 0.00254 [$.000100$] MIN THK PER ASTM B-545
- ③ GOLD PLATE 0.000076 [$.000003$] MIN THK PER ASTM B-488, TYPE 2, CODE C, OVER NICKEL PLATE, 0.00127 [$.000050$] MIN THK PER QQ-N-290.
- ④ COPPER PER ASTM B-152, ANNEALED
- ⑤ PRELIMINARY - NOT FOR PRODUCTION

③	⑤	320743-1
②		320743
FINISH		PART NO.

AMP INCORPORATED CUSTOMER SERVICE SYSTEMS		MAX RECOMMENDED OPERATING TEMPERATURE: 170°C
FOR ADDITIONAL PRODUCT INFORMATION OR COPIES OF DRAWINGS AND TECHNICAL DOCUMENTS	PRODUCT INFORMATION CENTER 1-800-522-6752	VOLTAGE RATING: N/A
FOR APPLICATION TOOLING INFORMATION	TOOLING ASSISTANCE CENTER 1-800-722-1111	CIRCULAR MIL AREA: 16.8-26.7mm ² [33,100-52,600] SOLID OR STRANDED
FOR ORDER ENTRY	1-800-526-5142	THIS DRAWING IS A CONTROLLED DOCUMENT FOR AMP INCORPORATED. IT IS SUBJECT TO CHANGE AND THE CONTROLLING ENGINEERING ORGANIZATION SHOULD BE CONTACTED FOR THE LATEST REVISION.

THIS DRAWING IS A CONTROLLED DOCUMENT.		DWN TA BRINKMAN 3-29-93	Tyco Electronics Corporation Harrisburg, Pa 17105-3608	
DIMENSIONS: MM [INCHES]		CHK DA PATTERSON 3-29-93	NAME JL MECKLEY 3-29-93	
TOLERANCES UNLESS OTHERWISE SPECIFIED:		APVD JL MECKLEY 3-29-93	PRODUCT SPEC	
0 PLC ± -		APPLICATION SPEC		
1 PLC ± -		WEIGHT		
2 PLC ± -		A2 00779 C=320743		
3 PLC ± -		SCALE 4:1 SHEET 1 OF 1 REV E		
4 PLC ± -		CUSTOMER DRAWING		
ANGLES ± -				
FINISH				
SEE TABLE				

320743

A