

320882 Product Details

[Share](#) [Print](#) [Email](#)



320882

TE Internal Number: 320882
 Active

[View 3D PDF](#)

Ring and Spade Tongue Terminals

Always EU RoHS/ELV Compliant (Statement of Compliance)

Product Highlights:

- Terminal Shape = Ring Tongue
- Receptacle Style = Straight
- Body Style = PIDG
- Barrel Type = Closed Barrel
- Wire/Cable Type = Regular Wire

[View all Features](#)

Quick Links

- [Pricing & Availability](#)
- [Search for Tooling](#)
- [Product Feature Selector](#)
- [Contact Us About This Product](#)

[Add to My Part List](#) [Request Sample](#) [Find Similar Products](#) [Buy Product](#)

Documentation & Additional Information

Product Drawings:

- [TERMINAL, RING TONGUE, PIDG TM WIRE SIZE, 22-16 AWG \(PDF, English\)](#)

Catalog Pages/Data Sheets:

- None Available

Product Specifications:

- None Available

Application Specifications:

- [Pre-Insulated Diamond Grip \(PIDG\) Terminals, Splices... \(PDF, English\)](#)

Instruction Sheets:

- None Available

CAD Files: [\(CAD Format & Compression Information\)](#)

- [2D Drawing \(DXF, Version H1\)](#)
- [3D Model \(IGES, Version H1\)](#)
- [3D Model \(STEP, Version H1\)](#)

[List all Documents](#)

Related Products:

- [Tooling](#)

Product Features (Please use the Product Drawing for all design activity)

Product Type Features:

- Terminal Shape = Ring Tongue
- Receptacle Style = Straight
- Barrel Type = Closed Barrel
- Wire/Cable Type = Regular Wire
- Insulation = Yes
- Insulation Support = Insulation Support
- Stud Diameter (mm [in]) = 3.02 [0.119]
- Stud Size = 4
- Shape = RING-041
- Heavy Duty = No
- Finish = Tin
- Color = Red

Electrical Characteristics:

- Voltage (VAC) = 300

Termination Features:

- Wire/Cable Size (CMA) = 509 - 3,260

Dimensions:

- Insulation Diameter (mm [in]) = 2.67 - 3.56 [.105 - .140]
- Length (mm [in]) = 16.99 [0.668]

Body Features:

- Body Style = PIDG
- Wire Range (mm [AWG]) = 0.30-1.40² [22-16]
- Material = Copper
- Tongue Material Thickness (mm [in]) = 0.79 [0.031]
- Insulation Material = Nylon
- Insulation Sleeve Material = Copper

Industry Standards:

- Government/Industry Qualification = No
- RoHS/ELV Compliance = RoHS compliant, ELV compliant
- Lead Free Solder Processes = Not relevant for lead free process
- RoHS/ELV Compliance History = Always was RoHS compliant

Packaging Features:

- Packaging Method = Loose Piece
- Packaging Quantity = 1,000

Other:

- Brand = AMP

Corporate Information

[About TE](#)
[Investors](#)
[News Room](#)

Quick Links

[Distributor Inventory](#)
[Product Cross Reference](#)
[Documents & Drawings](#)

Customer Support

[Email or Chat With Us](#)
[Find a Phone Number](#)
[Knowledge Base](#)

THIS DRAWING IS UNPUBLISHED. RELEASED FOR PUBLICATION
 © COPYRIGHT BY TYCO ELECTRONICS CORPORATION. ALL INTERNATIONAL RIGHTS RESERVED.

LOC	DIST	REVISIONS					
		P	LTR	DESCRIPTION	DATE	DWN	APVD
G	14		H1	REVISED PER ECR-09-009100	28APR09	HMR	TM

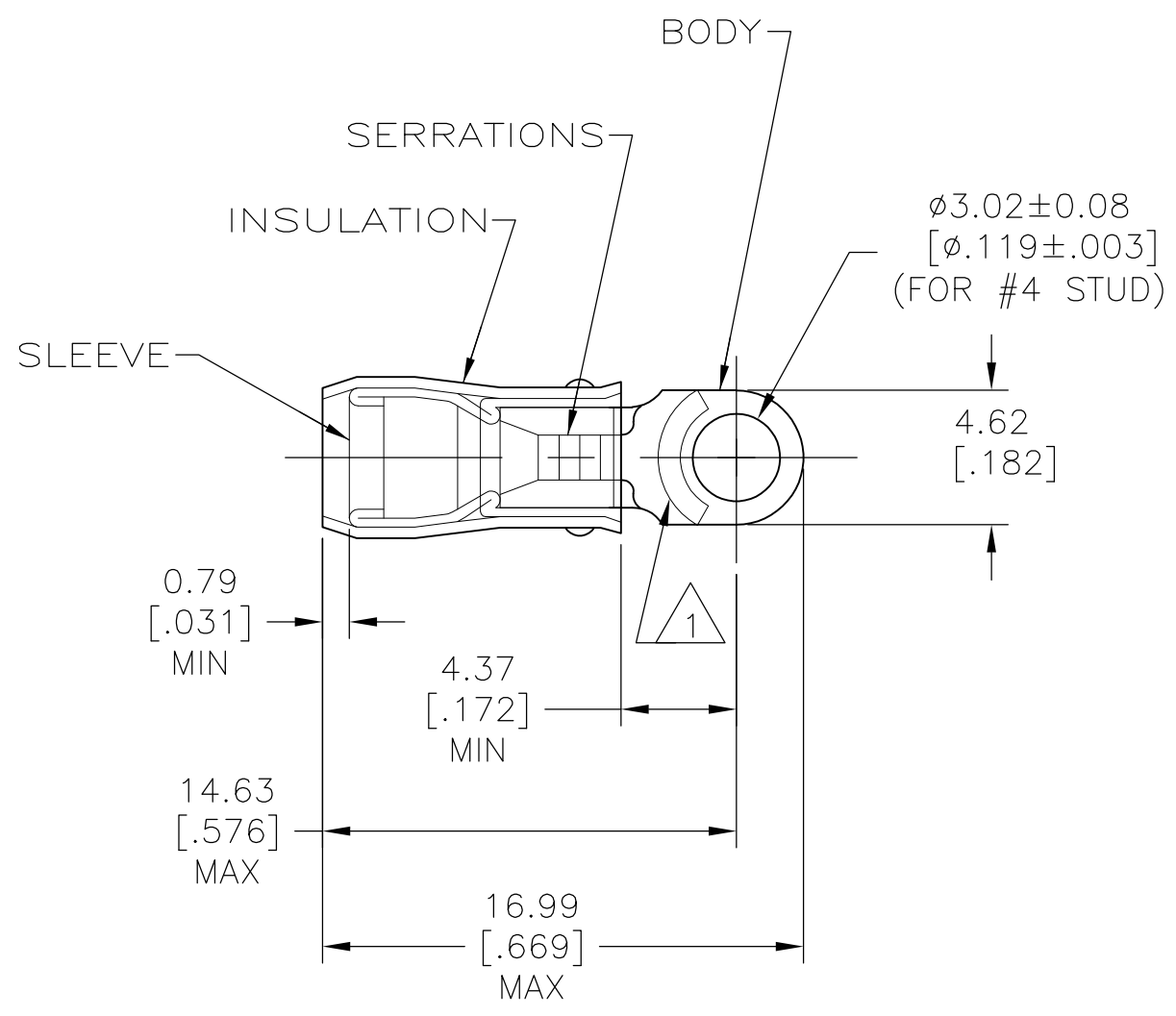

AMP WIRE RANGE	E13288	LR7189 Certified
22-16 AWG SOLID OR STRANDED	22-16 AWG SOLID OR STRANDED	22-16 AWG SOLID OR STRANDED

- 1 STAMP AMP 22-18* APPROX AS SHOWN
22-16 TERMINALS ARE STAMPED 22-18 IN
ACCORDANCE WITH MILITARY SPEC MIL-T-7928
COMMERCIAL WIRE RANGE IS 22-16
- 2 WIRE INSUL DIA, 2.67-3.56 [.105-.140]
- 3 TONGUE MATERIAL THK, 0.79 ± 0.05 [.031 ± .002]

100	LOOSE PIECE, BOX	8-320882-1
5000	ON TAPE, REEL	2-320882-1
1000	LOOSE PIECE	320882
QTY	PACKAGE TYPE	PART NO

AMP INCORPORATED CUSTOMER SERVICE SYSTEM		MAX RECOMMENDED OPERATING TEMPERATURE: 105° C [221° F]	THIS DRAWING IS A CONTROLLED DOCUMENT.		DWN M ELLIS 16JUN95	Tyco Electronics Corporation Harrisburg, PA 17105-3608					
FOR ADDITIONAL PRODUCT INFORMATION OR COPIES OF DRAWINGS AND TECHNICAL DOCUMENTS	PRODUCT INFORMATION CENTER 1-800-522-6752		VOLTAGE RATING: 300 V MAX -	DIMENSIONS: mm [INCHES]	TOLERANCES UNLESS OTHERWISE SPECIFIED:				CHK C PRESNELL 16JUN95	NAME TERMINAL, RING TONGUE, PIDG TM WIRE SIZE, 22-16 AWG	
FOR APPLICATION TOOLING INFORMATION	TOOLING ASSISTANCE CENTER 1-800-722-1111	CIRCULAR MIL AREA: 0.26mm ² - 1.65mm ² [509-3260]		0 PLC ± - 1 PLC ± - 2 PLC ± 0.20[.008] 3 PLC ± - 4 PLC ± - ANGLES ± -	APVD N BIRCH 16JUN95	PRODUCT SPEC UL 486A	SIZE	CAGE CODE	DRAWING NO	RESTRICTED TO	
FOR ORDER ENTRY	1-800-526-5142			MATERIAL BODY,SLV,COPPER PER ASTM-B-152 INSUL, NYLON, COLOR, RED	FINISH BODY & SLV,TIN PLATE PER ASTM-B-545			A3	00779	G-320882	
CUSTOMER DRAWING					WEIGHT	-	SCALE	4:1	SHEET	1 OF 1	REV H1