

Distributed by:

**JAMECO**<sup>®</sup>  
ELECTRONICS

**www.Jameco.com ♦ 1-800-831-4242**

The content and copyrights of the attached  
material are the property of its owner.

Jameco Part Number 842531

THIS DRAWING IS UNPUBLISHED. RELEASED FOR PUBLICATION ,19 .  
 © COPYRIGHT 19 BY AMP INCORPORATED. ALL INTERNATIONAL RIGHTS RESERVED.

LOC	DIST	P	F	ZONE	LTR	REVISIONS	DATE	APPD
G	14					G1 REVISED PER ECR 06-014478	14JUN06	JR MJS

**METRIC**  
 DIMENSIONS LISTED IN mm [ INCHES ]

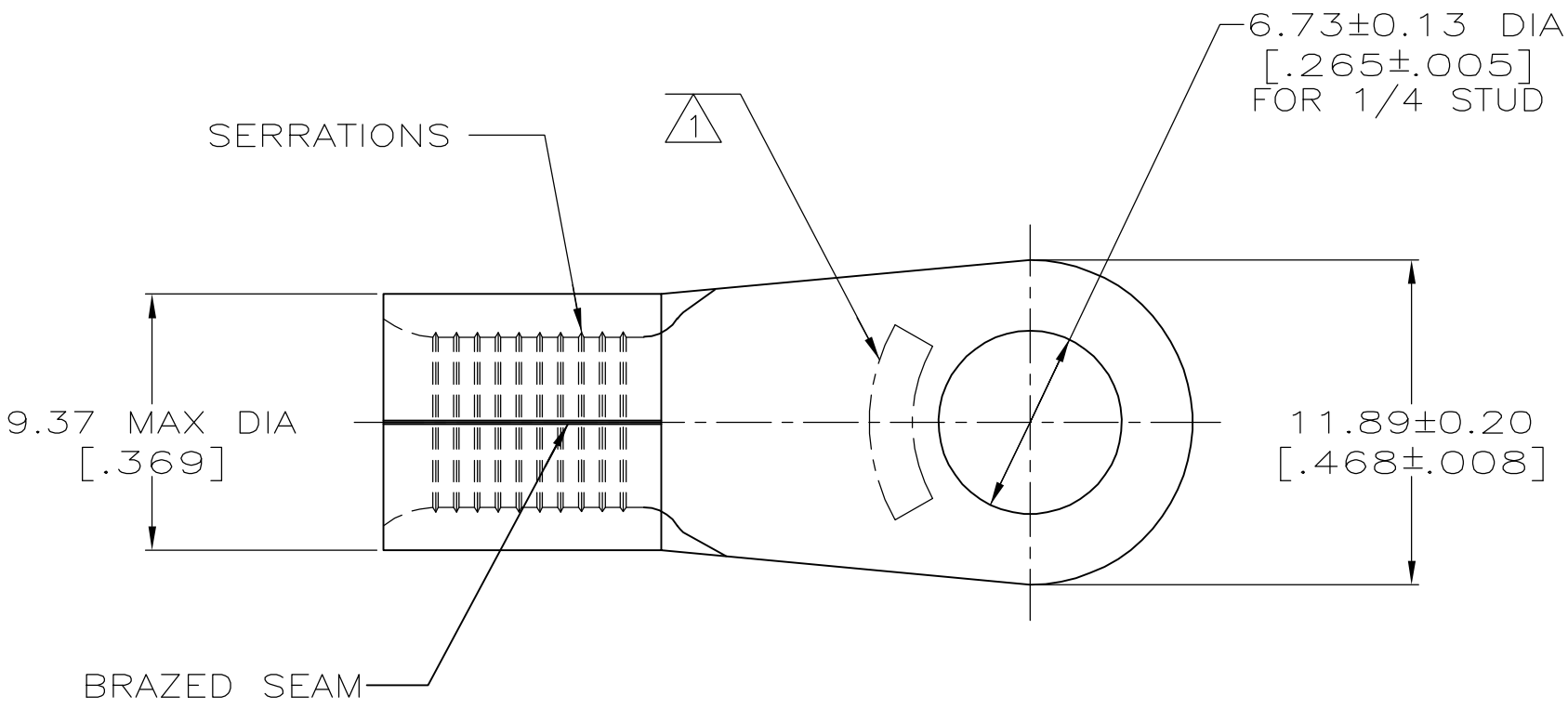

<b>AMP</b> WIRE RANGE	E13288 Listed
6 AWG SOLID OR STRANDED	6 AWG STRANDED
LR7189 Certified	MILITARY P/N AND CLASS
6 AWG SOLID OR STRANDED	MS 20659-109 CLASS 2 P/N 321598 ONLY

STAMP AMP 6\* APPROX AS SHOWN  
 P/N 2-321598-1 PRODUCED ONLY BY FOREIGN SUBSIDIARIES OF AMP INC

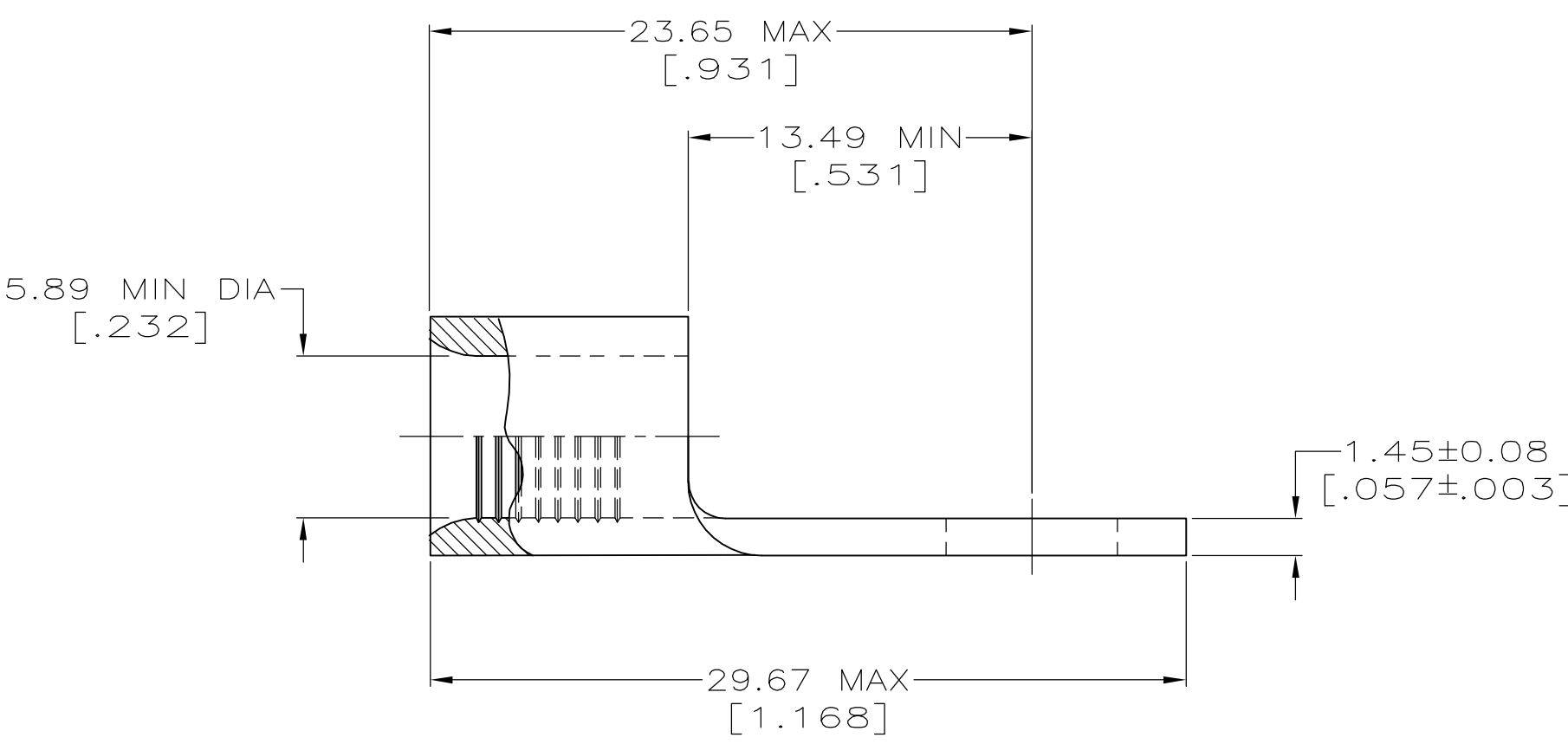

25	LOOSE PIECE BAG 321598	170° C	TIN PLATE 0.00254[.000100] MIN THK PER MIL-T-10727	8-321598-5
25	LOOSE PIECE BOX 321598	170° C	TIN PLATE 0.00254[.000100] MIN THK PER MIL-T-10727	8-321598-3
1000	LOOSE PIECE BOX 321598	170° C	TIN PLATE 0.00254[.000100] MIN THK PER MIL-T-10727	2-321598-4
750	321598 ON TAPE	170° C	TIN PLATE 0.00254[.000100] MIN THK PER MIL-T-10727	2-321598-3
----	LOOSE PIECE	----	GOLD PLATE TYPE II 0.00127 [0.00005] MIN THK PER MIL-G-45204 OVER NICKEL PLATE 0.000762 [0.00003] MIN THK PER QQ-N-290	2-321598-1
----	LOOSE PIECE	170° C	TIN PLATE 0.00254[.000100] MIN THK PER MIL-T-10727	321598

**AMP INCORPORATED**  
**CUSTOMER SERVICE SYSTEMS**

FOR ADDITIONAL PRODUCT INFORMATION OR COPIES OF DRAWINGS AND TECHNICAL DOCUMENTS	PRODUCT INFORMATION CENTER 1-800-522-6752
FOR APPLICATION TOOLING INFORMATION	TOOLING ASSISTANCE CENTER 1-800-722-1111
FOR ORDER ENTRY	1-800-526-5142

MAX RECOMMENDED OPERATING TEMPERATURE:  
 SEE TABLE

VOLTAGE RATING:  
 NOT APPLICABLE

WIRE CROSS SECTIONAL AREA RANGE:  
 10.5-16.8mm<sup>2</sup>[20,800-33,100] CIR MILS  
 SOLID OR STRANDED

THIS DRAWING IS A CONTROLLED DOCUMENT FOR AMP INCORPORATED. IT IS SUBJECT TO CHANGE AND THE CONTROLLING ENGINEERING ORGANIZATION SHOULD BE CONTACTED FOR THE LATEST REVISION.

DO NOT SCALE PRINT. UNLESS SPECIFIED DIMENSIONS IN mm [INCHES]— TOLERANCES ON :  
 2 PLC DEC ± -  
 3 PLC DEC ± -  
 ANGLES ± -

MATERIAL  
 COPPER PER ASTM B-152 ANNEALED

FINISH  
 SEE TABLE

DR 3-24-93  
 TA BRINKMAN  
 CHK 3-24-93  
 DA PATTERSON  
 APPD 3-24-93  
 DE MILLER  
 APPD 3-24-93  
 JL MECKLEY  
 PRODUCT SPEC -  
 APPLICATION SPEC -  
 WEIGHT -

**AMP** AMP Incorporated  
 Harrisburg, PA 17105-3608

NAME  
**TERMINAL, RING TONGUE, SOLISTRAND™**

SIZE	CAGE CODE	DRAWING NO
00779	00779	321598
SCALE	SHEET	
4:1	10F 1	