

THIS DRAWING IS UNPUBLISHED. RELEASED FOR PUBLICATION
 © COPYRIGHT - By - ALL RIGHTS RESERVED.

LOC	DIST	REVISIONS					
G	14	P	LTR	DESCRIPTION	DATE	DWN	APVD
			N2	REVISED PER ECO-15-006978	11MAY2015	NK	MM

AMP WIRE RANGE	Listed FILE E13288	LR7189 Certified
2 AWG SOLID OR STRANDED	2 AWG STRANDED	2 AWG SOLID OR STRANDED

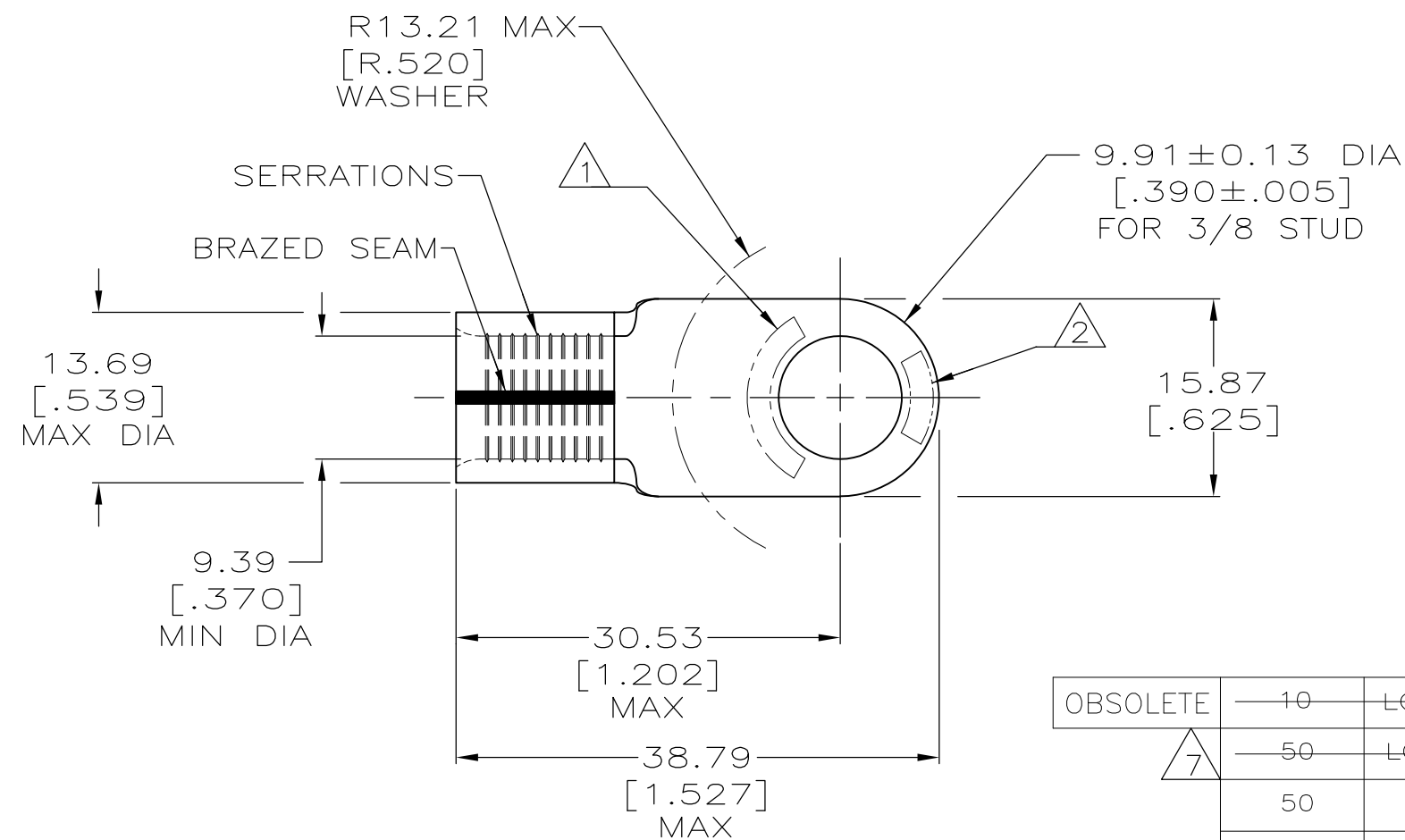

- 1 STAMP AMP 2W* APPROX AS SHOWN.
- 2 STAMP 60-75 APPROX AS SHOWN.
- 3 MATERIAL THK: 1.78±0.08[.070±.003].
- 4 TIN PLATE 0.00254[.000100] MIN THK PER ASTM B-545.
- 5 GOLD PLATE 0.00127[.000050] MIN THK PER ASTM B-488, TYPE 2, GRADE C, OVER NICKEL PL. 0.00076[.000030] MIN THK PER QQ-N-290.
- 6 MEETS MS20659-114, CLASS 2.
- 7 SUPERSEDED BY P/N 321600.

OBSOLETE	10	LOOSE PIECE, BAG		4	8-321600-5
	50	LOOSE PIECE, BOX	--	4	8-321600-2
	50	LOOSE PIECE	--	5	2-321600-1
	50	LOOSE PIECE	6	4	321600
	QTY	PACKAGE TYPE	MILITARY	FINISH	PART NO

CUSTOMER SERVICE SYSTEMS		MAX RECOMMENDED OPERATING TEMPERATURE: 170°C [338°F]	THIS DRAWING IS A CONTROLLED DOCUMENT.		DWN DK SCHRUM 5/25/93	TE Connectivity	
FOR ADDITIONAL PRODUCT INFORMATION OR COPIES OF DRAWINGS AND TECHNICAL DOCUMENTS	PRODUCT INFORMATION CENTER 1-800-522-6752	VOLTAGE RATING: N/A	DIMENSIONS: mm [INCHES]	TOLERANCES UNLESS OTHERWISE SPECIFIED:	CHK RD HEIM 1/27/94	NAME TERMINAL, RING TONGUE, SOLISTRAND	
FOR APPLICATION TOOLING INFORMATION	TOOLING ASSISTANCE CENTER 1-800-722-1111	CIRCULAR MIL AREA: 26.7-42.4mm² [52,600-83,700] SOLID OR STRANDED		0 PLC ± - 1 PLC ± - 2 PLC ± 0.20[.008] 3 PLC ± - 4 PLC ± - ANGLES ± -	APVD J MECKLEY 1/27/94	PRODUCT SPEC	RESTRICTED TO
FOR ORDER ENTRY	1-800-526-5142		MATERIAL COPPER ASTM B-152	FINISH SEE TABLE	APPLICATION SPEC	SIZE A3	CAGE CODE 00779
					WEIGHT -	DRAWING NO C-321600	SCALE 2:1
					CUSTOMER DRAWING	SHEET 1 OF 1	REV N2