

**METRIC**  
 DIMENSIONS LISTED IN mm [ INCHES ]

<b>AMP</b> WIRE RANGE	E13288 Listed
22-16 AWG SOLID OR STRANDED	NOT APPLICABLE
LR7189 Certified	MILITARY P/N AND CLASS
NOT APPLICABLE	NOT APPLICABLE

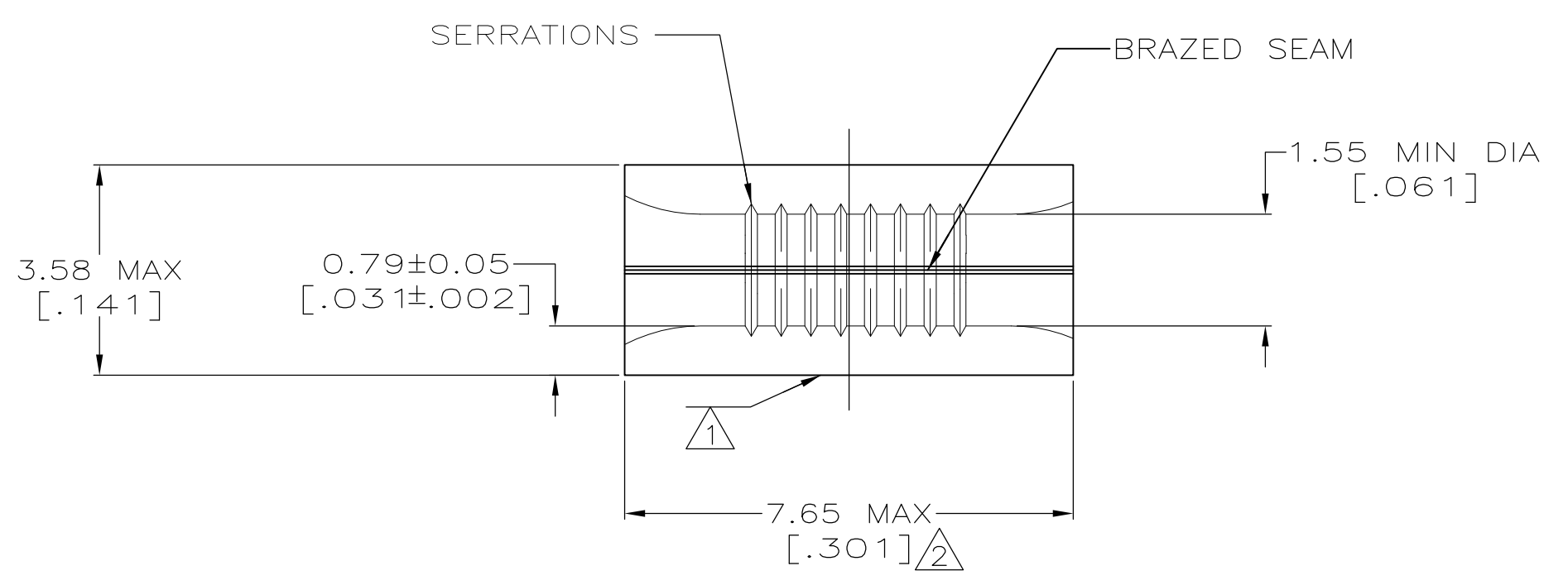

- △1 STAMP AMP 22-18\* APPROX AS SHOWN  
22-16 TERMINALS ARE STAMPED 22-18 IN ACCORDANCE WITH MILITARY SPECIFICATION MIL-T-7928; COMMERCIAL WIRE RANGE IS 22-16
- △2 MAXIMUM LENGTH DOES NOT INCLUDE MANUFACTURING TABS

<b>AMP INCORPORATED CUSTOMER SERVICE SYSTEMS</b>		MAX RECOMMENDED OPERATING TEMPERATURE: 343° C MAX
FOR ADDITIONAL PRODUCT INFORMATION OR COPIES OF DRAWINGS AND TECHNICAL DOCUMENTS	PRODUCT INFORMATION CENTER 1-800-522-6752	VOLTAGE RATING: NOT APPLICABLE
FOR APPLICATION TOOLING INFORMATION	TOOLING ASSISTANCE CENTER 1-800-722-1111	WIRE CROSS SECTIONAL AREA RANGE: 0.26-1.65mm <sup>2</sup> [509-3,260] CIR MILS SOLID OR STRANDED
FOR ORDER ENTRY	1-800-526-5142	THIS DRAWING IS A CONTROLLED DOCUMENT FOR AMP INCORPORATED. IT IS SUBJECT TO CHANGE AND THE CONTROLLING ENGINEERING ORGANIZATION SHOULD BE CONTACTED FOR THE LATEST REVISION.

THIS DRAWING IS A CONTROLLED DOCUMENT.		DWN TA BRINKMAN 4-19-93	TE Connectivity	
DIMENSIONS: mm[INCHES]		CHK DA PATTERSON 4-19-93	NAME DE MILLER 4-19-93	
TOLERANCES UNLESS OTHERWISE SPECIFIED: 0 PLC ± - 1 PLC ± - 2 PLC ± - 3 PLC ± - 4 PLC ± - ANGLES ± ± -		APVD DE MILLER 4-19-93	PRODUCT SPEC APPLICATION SPEC	
MATERIAL COPPER PER ASTM B-152 ANNEALED	FINISH NICKEL PLATE 0.00762[.000300] MIN THK PER QQ-N-290	WEIGHT -	SIZE A2	CAGE CODE 00779
CUSTOMER DRAWING		DRAWING NO G-323030	RESTRICTED TO -	SCALE 10:1 SHEET 1 OF 1 REV D1