



Have a Question?  
Chat with a Product  
Information Specialist

What can we help you find?

[Products](#) [Industries](#) [Resources](#) [About TE](#) [My Account](#) [Innovation](#) [Support Center](#)

## 32562 Product Details

[Share](#) [Print](#) [Email](#)



**32562**

TE Internal Number: 32562

Active

[View 3D PDF](#)

### Ring and Spade Tongue Terminals

Always EU RoHS/ELV Compliant (Statement of Compliance)

#### Product Highlights:

- Terminal Shape = Spade Tongue, Flanged
- Receptacle Style = Straight
- Body Style = PIDG
- Barrel Type = Closed Barrel
- Wire/Cable Type = Regular Wire

[View all Features](#)

### Quick Links

- ▶ [Pricing & Availability](#)
- ▶ [Search for Tooling](#)
- ▶ [Product Feature Selector](#)
- ▶ [Contact Us About This Product](#)

[Add to My Part List](#) [Request Sample](#) [Find Similar Products](#) [Buy Product](#)

### Documentation & Additional Information

#### Product Drawings:

- [WIRE TERMINAL, PIDG, FLANGED SPADE, 22-16 AWG \(PDF, English\)](#)

#### Catalog Pages/Data Sheets:

- None Available

#### Product Specifications:

- None Available

#### Application Specifications:

- [Pre-Insulated Diamond Grip \(PIDG\) Terminals, Splices... \(PDF, English\)](#)

#### Instruction Sheets:

- None Available

#### CAD Files: [\(CAD Format & Compression Information\)](#)

- [2D Drawing \(DXF, Version S\)](#)
- [3D Model \(IGES, Version S\)](#)
- [3D Model \(STEP, Version S\)](#)

[List all Documents](#)

#### Related Products:

- [Tooling](#)

### Product Features (Please use the Product Drawing for all design activity)

#### Product Type Features:

- Terminal Shape = Spade Tongue, Flanged
- Receptacle Style = Straight
- Barrel Type = Closed Barrel
- Wire/Cable Type = Regular Wire
- Insulation = Yes
- Insulation Support = Insulation Support
- Stud Diameter (mm [in]) = 3.68 [0.145]
- Stud Size = 6 [M3.5]
- Shape = SPADE-024
- Heavy Duty = No
- Finish = Tin
- Color = Red

#### Electrical Characteristics:

- Voltage (VAC) = 300

#### Termination Features:

- Wire/Cable Size (CMA) = 509 - 3,260

#### Dimensions:

- Insulation Diameter (mm [in]) = 2.67 - 3.56 [.105 - .140]
- Length (mm [in]) = 18.72 [0.737]
- Width (mm [in]) = 7.52 [0.296]

#### Body Features:

- Body Style = PIDG
- Wire Range (mm [AWG]) = 0.30-1.40<sup>2</sup> [22-16]
- Material = Copper
- Tongue Material Thickness (mm [in]) = 0.79 [0.031]
- Insulation Material = Nylon
- Insulation Sleeve Material = Copper

#### Industry Standards:

- Government/Industry Qualification = No
- RoHS/ELV Compliance = RoHS compliant, ELV compliant
- Lead Free Solder Processes = Not relevant for lead free process
- RoHS/ELV Compliance History = Always was RoHS compliant

#### Packaging Features:

- Packaging Method = Loose Piece

#### Other:

- Brand = AMP

THIS DRAWING IS UNPUBLISHED. RELEASED FOR PUBLICATION  
 © COPYRIGHT - By - ALL RIGHTS RESERVED.

LOC	DIST	REVISIONS					
G	14	P	LTR	DESCRIPTION	DATE	DWN	APVD
		S1		REVISED PER ECO-11-004820	11MAR11	RK	HMR

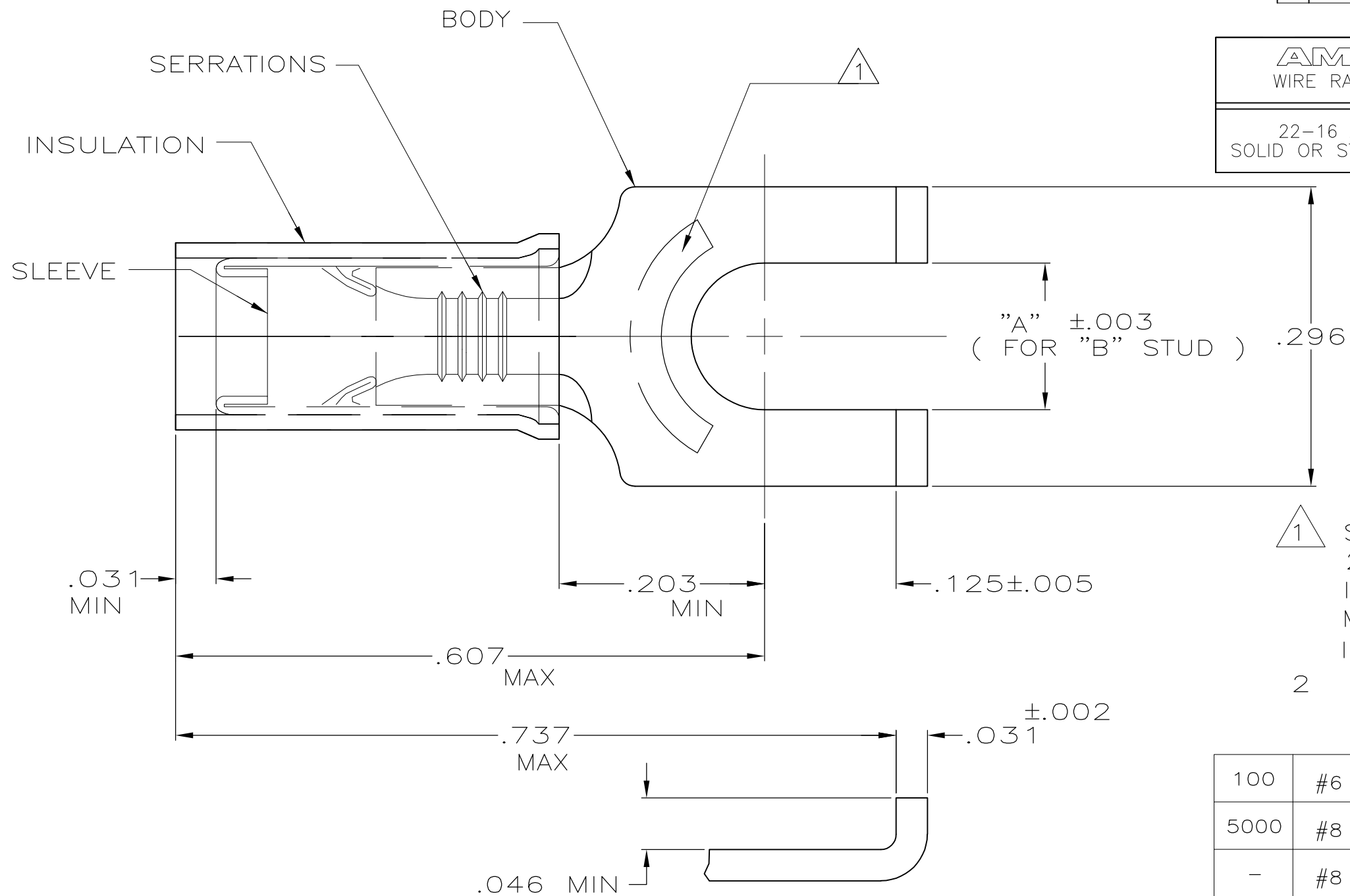

<b>AMP</b> WIRE RANGE	Listed	LR7189 Certified
22-16 AWG SOLID OR STRANDED	22-16 AWG SOLID OR STRANDED	22-16 AWG SOLID OR STRANDED

1 STAMP AMP 22-18\* APPROX AS SHOWN  
 22-16 TERMINALS ARE STAMPED 22-18  
 IN ACCORDANCE WITH MILITARY SPEC  
 MIL-T-7928, COMMERCIAL WIRE RANGE  
 IS 22-16.  
 2 WIRE INSULATION DIA IS .105-.140

100	#6	.145	LOOSE PIECE, BOX	8-32562-1
5000	#8	.171	ON TAPE, REEL	2-32562-3
-	#8	.171	LOOSE PIECE	2-32562-2
5000	#6	.145	ON TAPE, REEL	2-32562-1
-	#6	.145	LOOSE PIECE	32562
QTY	"B"	"A"	DESCRIPTION	PART NO.

**AMP INCORPORATED  
 CUSTOMER SERVICE SYSTEMS**

FOR ADDITIONAL PRODUCT INFORMATION OR COPIES OF DRAWINGS AND TECHNICAL DOCUMENTS	PRODUCT INFORMATION CENTER 1-800-522-6752
FOR APPLICATION TOOLING INFORMATION	TOOLING ASSISTANCE CENTER 1-800-722-1111
FOR ORDER ENTRY	1-800-526-5142

MAX RECOMMENDED OPERATING  
TEMPERATURE:  
105° C MAX

VOLTAGE RATING:  
300 V MAX

WIRE CROSS SECTIONAL AREA RANGE:  
0.26-1.65mm<sup>2</sup> [509-3,260] CIR MILS  
SOLID OR STRANDED

THIS DRAWING IS A CONTROLLED DOCUMENT.

DIMENSIONS: INCHES	TOLERANCES UNLESS OTHERWISE SPECIFIED:
	0 PLC ± - 1 PLC ± - 2 PLC ± - 3 PLC ± .008 4 PLC ± - ANGLES ± -
MATERIAL BODY & SLEEVE: COPPER PER ASTM B152 INSULATION: NYLON-RED	FINISH BODY: TIN PLATE PER ASTM B545

DWN JR RUTH 24JUL02	TE Connectivity
CHK T MICHIELUTTI 24JUL02	
APVD T MICHIELUTTI 24JUL02	
NAME	
PRODUCT SPEC	WIRE TERMINAL, PIDG, FLANGED SPADE, 22-16 AWG
APPLICATION SPEC	SIZE: A3 CAGE CODE: 00779 DRAWING NO: C-32562 RESTRICTED TO: -
WEIGHT: -	CUSTOMER DRAWING SCALE: 8:1 SHEET: 1 OF 1 REV: S1