

## 327638 Product Details

[Share](#) [Print](#) [Email](#)



**327638**

TE Internal Number: 327638

Active

[View 3D PDF](#)

### Splices - Closed Barrel

Converted to EU RoHS/ELV Compliant  
(Statement of Compliance)

#### Product Highlights:

- Splice
- Not Sealed
- Splice Type = Butt
- Butt Splice Type = Step Down
- Body Style = PIDG

[View all Features](#)

### Quick Links

- ▶ [Pricing & Availability](#)
- ▶ [Search for Tooling](#)
- ▶ [Product Feature Selector](#)
- ▶ [Contact Us About This Product](#)

[Add to My Part List](#) [Request Sample](#) [Find Similar Products](#) [Buy Product](#)

### Documentation & Additional Information

#### Product Drawings:

- [SPLICE, BUTT, PIDG WIRE SIZE: 12-10 TO 16-14 AWG](#) (PDF, English)

#### Catalog Pages/Data Sheets:

- None Available

#### Product Specifications:

- None Available

#### Application Specifications:

- [Pre-Insulated Diamond Grip \(PIDG\) Terminals, Splices...](#) (PDF, English)

#### Instruction Sheets:

- [PIDG Butt Splices with Adapters](#) (PDF, English)

#### CAD Files: [\(CAD Format & Compression Information\)](#)

- [2D Drawing](#) (DXF, Version L)
- [3D Model](#) (IGES, Version L)
- [3D Model](#) (STEP, Version L)

[List all Documents](#)

#### Related Products:

- [Tooling](#)

### Product Features (Please use the Product Drawing for all design activity)

#### Product Type Features:

- [Product Type](#) = Splice
- [Sealed](#) = No
- [Splice Type](#) = Butt
- [Insulation](#) = Yes
- [Insulation Support](#) = Insulation Support
- [Finish](#) = Tin
- [Color](#) = Yellow

#### Termination Features:

- [Wire/Cable Size \(CMA\)](#) = 5,180 - 13,100

#### Dimensions:

- [Insulation Diameter \(mm \[in\]\)](#) = 5.59/4.32 [.220/.170] Max.

#### Body Features:

- [Butt Splice Type](#) = Step Down
- [Body Style](#) = PIDG
- [Wire Range \(mm \[AWG\]\)](#) = 3.00-6.00 to 1.25-2.00<sup>2</sup> [12-10 to 16-14]
- [Material](#) = Copper
- [Insulation Sleeve Material](#) = Nylon

#### Industry Standards:

- [Government/Industry Qualification](#) = No
- [RoHS/ELV Compliance](#) = RoHS compliant, ELV compliant
- [Lead Free Solder Processes](#) = Not relevant for lead free process
- [RoHS/ELV Compliance History](#) = Converted to comply with RoHS directive

#### Packaging Features:

- [Packaging Method](#) = Loose Piece

#### Other:

- [Brand](#) = AMP

### Corporate Information

[About TE](#)  
[Investors](#)  
[News Room](#)  
[Supplier Portal](#)

### Quick Links

[Distributor Inventory](#)  
[Product Cross Reference](#)  
[Documents & Drawings](#)  
[Product Compliance Support Center](#)

### Customer Support

[Email or Chat With Us](#)  
[Find a Phone Number](#)  
[Knowledge Base](#)  
[Manage Your Account](#)

THIS DRAWING IS UNPUBLISHED. RELEASED FOR PUBLICATION  
 © COPYRIGHT - By - ALL RIGHTS RESERVED.

LOC	DIST	REVISIONS			
P	LTR	DESCRIPTION	DATE	DWN	APVD
G	14	L1	REVISED PER ECO-11-004917	11MAR11	RK HMR

<b>AMP</b> WIRE RANGE	Listed FILE E13288	LR7189 Certified
12-10 TO 16-14 AWG STRANDED	12-10 TO 16-14 AWG STRANDED	12-10 TO 16-14 AWG STRANDED

1. WIRE INSULATION DIA 3.81[.150] TO 5.59[.220]  
WIRE INSULATION DIA 2.67[.105] TO 4.32[.170]
2. TAPED PART LONG, CRIMP ONLY IN TAPETRONICS
3. TAPE APPLIED TO PART SUCH THAT ADAPTER END IS CRIMPED IN APPLICATOR.
4. COPPER PER ASTM B-152  
NYLON, YELLOW
5. TIN PLATE PER ASTM B-545
6. PARTS MANUFACTURED AFTER MAY 2005 ARE ROHS COMPLIANT.

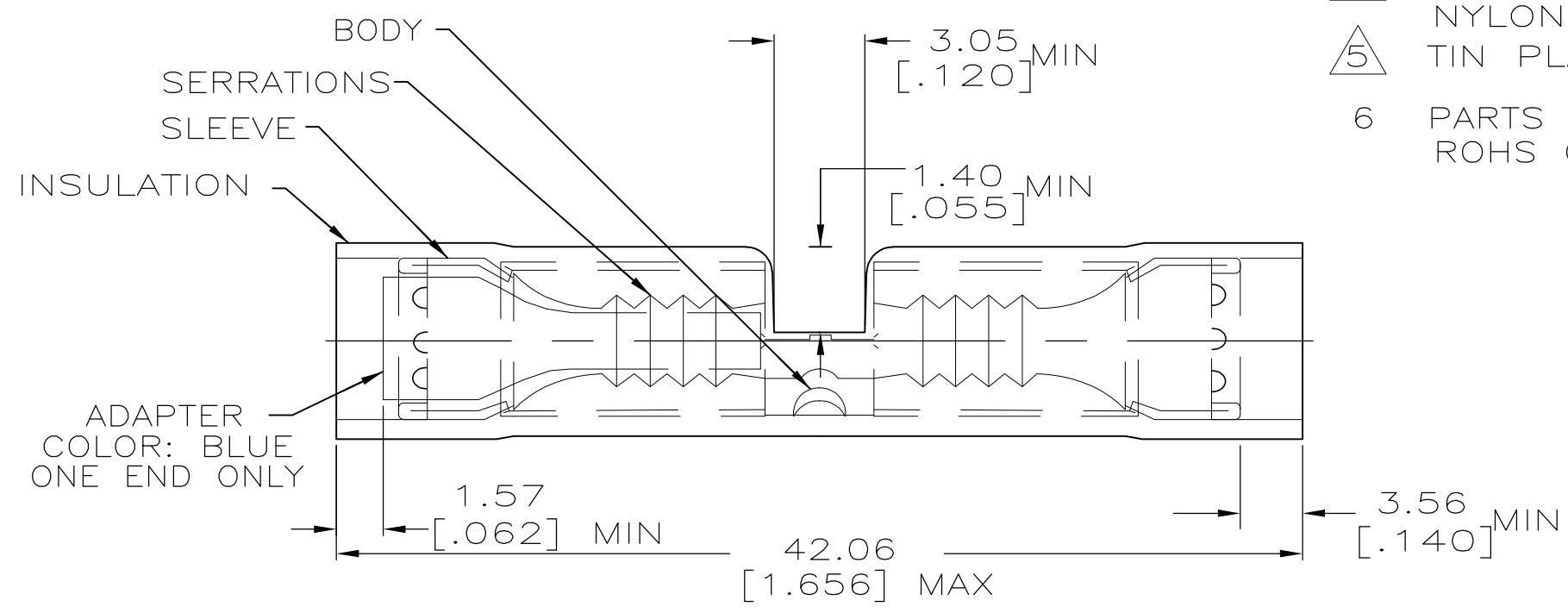

	1500	TAPE, REEL	2-327638-1
	50	LOOSE PIECE	327638
	QTY	PACKAGE TYPE	PART NO

<b>AMP INCORPORATED CUSTOMER SERVICE SYSTEMS</b>		MAX RECOMMENDED OPERATING TEMPERATURE: 105° C	THIS DRAWING IS A CONTROLLED DOCUMENT.		DWN JR RUTH 17DEC02	TE Connectivity				
FOR ADDITIONAL PRODUCT INFORMATION OR COPIES OF DRAWINGS AND TECHNICAL DOCUMENTS	PRODUCT INFORMATION CENTER 1-800-522-6752	VOLTAGE RATING: 300V MAX	DIMENSIONS: INCHES	TOLERANCES UNLESS OTHERWISE SPECIFIED:	CHK T MICHELUTTI 17DEC02				NAME SPLICE, BUTT, PIDG WIRE SIZE: 12-10 TO 16-14 AWG	
FOR APPLICATION TOOLING INFORMATION	TOOLING ASSISTANCE CENTER 1-800-722-1111	CIRCULAR MIL AREA: 2.62-6.64mm <sup>2</sup> [5,180-13,100] 1.04-2.62mm <sup>2</sup> [2,050-5,180] STRANDED		0 PLC ± - 1 PLC ± - 2 PLC ± 0.20[.008] 3 PLC ± - 4 PLC ± - ANGLES ± -	APVD T MICHELUTTI 17DEC02	PRODUCT SPEC	SIZE	CAGE CODE	DRAWING NO	RESTRICTED TO
FOR ORDER ENTRY	1-800-526-5142	THIS DRAWING IS A CONTROLLED DOCUMENT FOR AMP INCORPORATED. IT IS SUBJECT TO CHANGE AND THE CONTROLLING ENGINEERING ORGANIZATION SHOULD BE CONTACTED FOR THE LATEST REVISION.	MATERIAL COPPER	FINISH TIN PLATE	APPLICATION SPEC	WEIGHT	A3	00779	C-327638	-
CUSTOMER DRAWING						SCALE	1:1	SHEET	1 OF 1	REV L1