

Distributed by:

**JAMECO**<sup>®</sup>  
ELECTRONICS

**www.Jameco.com ♦ 1-800-831-4242**

The content and copyrights of the attached  
material are the property of its owner.

Jameco Part Number 751672

THIS DRAWING IS UNPUBLISHED. RELEASED FOR PUBLICATION, 19 .  
 © COPYRIGHT 19 BY AMP INCORPORATED. ALL INTERNATIONAL RIGHTS RESERVED.

| LOC | DIST | P | F | REVISIONS |     |                    |         |       |
|-----|------|---|---|-----------|-----|--------------------|---------|-------|
| G   | 14   |   |   | ZONE      | LTR | DESCRIPTION        | DATE    | APPD  |
|     |      |   |   |           | J   | REV / 0L20-0025-97 | 27JAN97 | ME TM |

|                                |                                |                                |
|--------------------------------|--------------------------------|--------------------------------|
| <b>AMP</b><br>WIRE RANGE       | <b>UL</b> Listed               | <b>SR</b> LR7189<br>Certified  |
| 22-16 AWG<br>SOLID OR STRANDED | 22-16 AWG<br>SOLID OR STRANDED | 22-16 AWG<br>SOLID OR STRANDED |

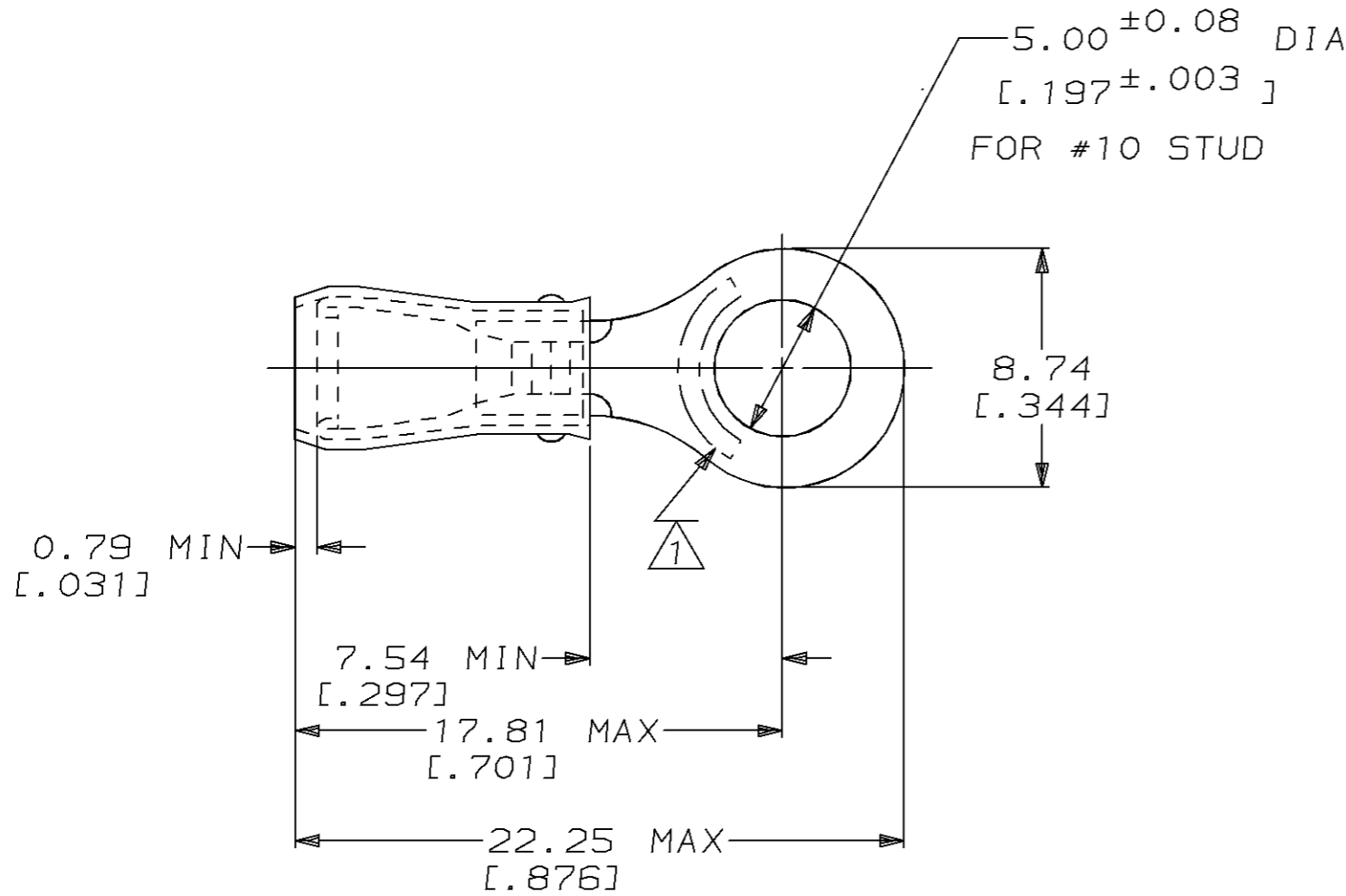

- 1 STAMP AMP 22-18\* APPROX AS SHOWN  
22-16 TERMINALS ARE STAMPED 22-18 IN  
ACCORDANCE WITH MILITARY SPEC MIL-T-7928  
COMMERCIAL WIRE RANGE IS 22-16
- 2 WIRE INSULATION DIA: .105 - .140
- 3 TONGUE MATERIAL THK: 0.79<sup>±0.05</sup> [0.031<sup>±.002</sup>]

| -   | 100  | LOOSE PIECE BOX   | 8-32837-1          |
|---|--|---|--------------------|
| -   | 5000   | ON TAPE, REEL   | 32837-1            |
| -   | -  | LOOSE PIECE   | 32837              |
| MILITARY P/N AND CLASS  | QUANTITY   | PACKAGE TYPE  | PART NO            |
| DO NOT SCALE PRINT.<br>UNLESS SPECIFIED<br>DIMENSIONS IN mm [INCHES]<br>TOLERANCES ON:<br>2 PLC DEC ± 0.20 [0.008]<br>3 PLC DEC ± -<br>ANGLES ± - | DR 02/11/93<br>DK SCHRUM<br>CHK 4/28/93<br>RE HERSEY<br>APPD 4/28/93<br>ML ELLIS<br>APPD 4/28/93<br>M BARNABA<br>PRODUCT SPEC<br>UL 486A | <b>AMP</b> AMP Incorporated<br>Harrisburg, PA 17105-3608      |                    |
| MATERIAL<br>COPPER ASTM B-152<br>SLEEVE, RED NYLON  | FINISH<br>TIN PLATE<br>PER MIL-T-10727   | NAME<br>TERMINAL, RING TONGUE,<br>PIDG™, WIRE SIZE, 22-16 AWG |                    |
|   | APPLICATION SPEC<br>NOT AVAILABLE  | SIZE<br>B   | CAGE CODE<br>00779 |
|   | WEIGHT -   | DRAWING NO<br>C-32837   | SHEET<br>1 OF 1    |
|   |  | SCALE<br>4:1  |                    |

**AMP INCORPORATED  
CUSTOMER SERVICE SYSTEMS**

|   |  |
|---|--|
| FOR ADDITIONAL<br>PRODUCT INFORMATION OR<br>COPIES OF DRAWINGS<br>AND TECHNICAL DOCUMENTS | PRODUCT INFORMATION CENTER<br>1-800-522-6752 |
| FOR APPLICATION<br>TOOLING INFORMATION  | TOOLING ASSISTANCE CENTER<br>1-800-722-1111  |
| FOR ORDER ENTRY   | 1-800-526-5142                               |

MAX RECOMMENDED OPERATING  
TEMPERATURE:  
105°C MAX

VOLTAGE RATING:  
300 V MAX

WIRE CROSS SECTIONAL AREA RANGE:  
0.26-1.65mm<sup>2</sup> [509-3,260] CIR MILS  
SOLID OR STRANDED

THIS DRAWING IS A CONTROLLED DOCUMENT FOR  
AMP INCORPORATED. IT IS SUBJECT TO CHANGE  
AND THE CONTROLLING ENGINEERING ORGANIZATION  
SHOULD BE CONTACTED FOR THE LATEST REVISION.