



Have a Question?
 Chat with a Product
 Information Specialist

What can we help you find?

[Products](#) |
 [Industries](#) |
 [Resources](#) |
 [About TE](#) |
 [My Account](#) |
 [Innovation](#) |
 [Support Center](#)

34855 Product Details

[Share](#) |
 [Print](#) |
 [Email](#)



34855

TE Internal Number: 34855

Active

[View 3D PDF](#)

Ring and Spade Tongue Terminals

Always EU RoHS/ELV Compliant (Statement of Compliance)

Product Highlights:

- Terminal Shape = Ring Tongue
- Receptacle Style = Straight
- Body Style = PLASTI-GRIP
- Barrel Type = Closed Barrel
- Wire/Cable Type = Regular Wire

[View all Features](#)

Quick Links

- ▶ [Pricing & Availability](#)
- ▶ [Search for Tooling](#)
- ▶ [Product Feature Selector](#)
- ▶ [Contact Us About This Product](#)

[Add to My Part List](#) |
 [Request Sample](#) |
 [Find Similar Products](#) |
 [Buy Product](#)

Documentation & Additional Information

Product Drawings:

- [TERMINAL, RING TONGUE, PLASTI-GRIP WIRE SIZE: 12-10 AWG \(PDF, English\)](#)

Catalog Pages/Data Sheets:

- None Available

Product Specifications:

- None Available

Application Specifications:

- [PLASTI-GRIP Terminals and Splices \(PDF, English\)](#)

Instruction Sheets:

- None Available

CAD Files: [\(CAD Format & Compression Information\)](#)

- [2D Drawing \(DXF, Version AA\)](#)
- [3D Model \(IGES, Version AA\)](#)
- [3D Model \(STEP, Version AA\)](#)

[List all Documents](#)

Related Products:

- [Tooling](#)

Product Features (Please use the Product Drawing for all design activity)

Product Type Features:

- Terminal Shape = Ring Tongue
- Receptacle Style = Straight
- Barrel Type = Closed Barrel
- Wire/Cable Type = Regular Wire
- Insulation = Yes
- Insulation Support = Insulation Support
- Stud Diameter (mm [in]) = 6.35 [0.250]
- Stud Size = 1/4 [M6]
- Shape = RING-043
- Heavy Duty = No
- Finish = Tin
- Color = Yellow

Electrical Characteristics:

- Voltage (VAC) = 600

Termination Features:

- Wire/Cable Size (CMA) = 5,180 - 13,100

Dimensions:

- Insulation Diameter (mm [in]) = 6.35 [.250] Max.

Body Features:

- Body Style = PLASTI-GRIP
- Wire Range (mm [AWG]) = 3.00-6.00² [12-10]
- Material = Copper
- Tongue Material Thickness (mm [in]) = 1.07 [0.042]
- Insulation Material = Vinyl

Industry Standards:

- Government/Industry Qualification = No
- RoHS/ELV Compliance = RoHS compliant, ELV compliant
- Lead Free Solder Processes = Not relevant for lead free process
- RoHS/ELV Compliance History = Always was RoHS compliant

Packaging Features:

- Packaging Method = Loose Piece

Other:

- Brand = AMP

Corporate Information

[About TE](#)
[Investors](#)
[News Room](#)

Quick Links

[Distributor Inventory](#)
[Product Cross Reference](#)
[Documents & Drawings](#)

Customer Support

[Email or Chat With Us](#)
[Find a Phone Number](#)
[Knowledge Base](#)

LOC	DIST	REVISIONS					
G	14	P	LTR	DESCRIPTION	DATE	DWN	APVD
			N2	REVISED PER ECO-11-004820	11MAR11	RK	HMR

AMP WIRE RANGE	Listed FILE E13288	LR7189 Certified
12-10 AWG SOLID OR STRANDED	12-10 AWG SOLID OR STRANDED	12-10 AWG SOLID OR STRANDED

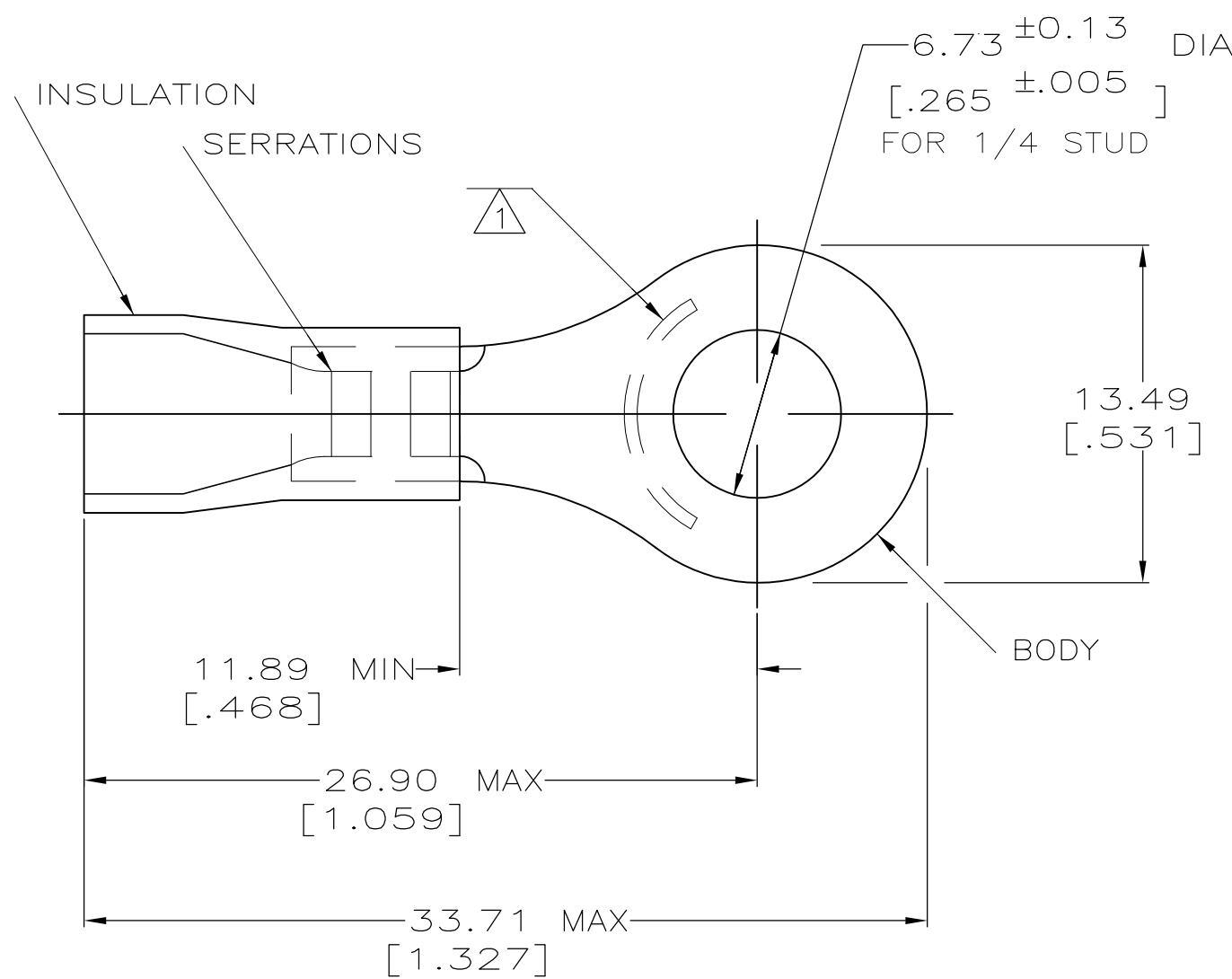

- ① STAMP AMP 12-10* APPROX AS SHOWN
- 2 WIRE INSULATION DIA: .150-.250
- 3 TONGUE MATERIAL THK: 0.99 ^{±0.05} [.039 ^{±0.002}]
- ④ TIN PLATE PER ASTM B 545
- ⑤ GOLD FLASH PLATE
- ⑥ INSULATION COLOR, YELLOW FOR P/N'S 34855, 2-34855-1, 8-34855-2 & 8-34855-4
- ⑦ INSULATION COLOR, RED FOR P/N'S 34855-1 & 2-34855-7
- ⑧ MATERIAL: BODY - CU PER ASTM B152
SLEEVE - PVC, COLOR - SEE NOTES 6 & 7

④	4	LOOSE PC,BLS	8-34855-4
④	50	LOOSE PC,BOX	8-34855-2
⑤	2500	ON TAPE, REEL	2-34855-7
④	2500	ON TAPE, REEL	2-34855-1
⑤	-	LOOSE PIECE	34855-1
④	-	LOOSE PIECE	34855
	QTY	PACKAGE TYPE	PART NO.

AMP INCORPORATED CUSTOMER SERVICE SYSTEMS		MAX RECOMMENDED OPERATING TEMPERATURE: 105°C [221°F]	THIS DRAWING IS A CONTROLLED DOCUMENT.		DWN DK SCHRUM 08/06/92	TE Connectivity				
FOR ADDITIONAL PRODUCT INFORMATION OR COPIES OF DRAWINGS AND TECHNICAL DOCUMENTS	PRODUCT INFORMATION CENTER 1-800-522-6752	VOLTAGE RATING: N/A	DIMENSIONS: mm [INCHES]	TOLERANCES UNLESS OTHERWISE SPECIFIED:	CHK RE HERSEY 11/10/92	NAME M BARNABA				
FOR APPLICATION TOOLING INFORMATION	TOOLING ASSISTANCE CENTER 1-800-722-1111	CIRCULAR MIL AREA: 2.62-6.64mm² [5,180-13,100] SOLID OR STRANDED		0 PLC ± - 1 PLC ± - 2 PLC ± 0.20[.008] 3 PLC ± - 4 PLC ANGLES ± -	APVD M BARNABA 11/10/92	PRODUCT SPEC 108-1034				
FOR ORDER ENTRY	1-800-526-5142	THIS DRAWING IS A CONTROLLED DOCUMENT FOR AMP INCORPORATED. IT IS SUBJECT TO CHANGE AND THE CONTROLLING ENGINEERING ORGANIZATION SHOULD BE CONTACTED FOR THE LATEST REVISION.	MATERIAL - ⑧	FINISH SEE NOTES 4 & 5	APPLICATION SPEC NOT AVAILABLE	SIZE A3	CAGE CODE 00779	DRAWING NO C-34855	RESTRICTED TO -	
					WEIGHT -	CUSTOMER DRAWING		SCALE 4:1	SHEET 1 OF 1	REV N2