



Have a Question?
 Chat with a Product
 Information Specialist

What can we help you find?

[Products](#) |
 [Industries](#) |
 [Resources](#) |
 [About TE](#) |
 [My Account](#) |
 [Innovation](#) |
 [Support Center](#)

3-643817-5 Product Details

[Share](#) |
 [Print](#) |
 [Email](#)

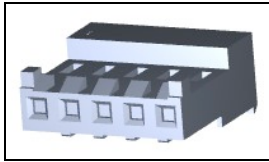

3-643817-5

TE Internal Number: 3-643817-5
✔ Active

[View 3D PDF](#)

MTA, CST-100 II, MT-6 and SL Connectors and Headers

✔ Always EU RoHS/ELV Compliant (Statement of Compliance)

Product Highlights:

- MTA-156 Product Line
- MTA Series
- Wire-to-Post
- Applies To Wire/Cable
- Connector

[View all Features](#)

Quick Links

- ▶ [Pricing & Availability](#)
- ▶ [Search for Tooling](#)
- ▶ [View Mating Products \(27\)](#)
- ▶ [Product Feature Selector](#)
- ▶ [Contact Us About This Product](#)

[Add to My Part List](#) |
 [Request Sample](#) |
 [Find Similar Products](#) |
 [Buy Product](#)

Documentation & Additional Information

Product Drawings:

- [MTA 156 CONNECTOR ASSEMBLY, 18 AWG, STANDARD \(PDF, English\)](#)

Catalog Pages/Data Sheets:

- [MTA, CST-100 II, SL-156 and AMP Economy Power \(EP\) C... \(PDF, English\)](#)

Product Specifications:

- [System, Connector/Header, MTA 156 \(PDF, English\)](#)

Application Specifications:

- [MTA 156 Connectors \(PDF, English\)](#)
- [MTA 156 Ribbon Cable Connector Assemblies \(English A... \(PDF, English\)](#)
- [MTA 156 Ribbon Cable Connector Assemblies \(English A... \(PDF, Japanese\)](#)

Instruction Sheets:

- None Available

CAD Files: [\(CAD Format & Compression Information\)](#)

- [2D Drawing \(DXF, Version H\)](#)
- [3D Model \(IGES, Version H\)](#)
- [3D Model \(STEP, Version H\)](#)

[List all Documents](#)

Additional Information:

- [Product Line Information](#)

Related Products:

- [Tooling](#)
- [Mating Products \(27\)](#)

Product Features (Please use the Product Drawing for all design activity)

Product Type Features:

- [Product Line](#) = MTA-156
- Series = MTA
- Product Type = Connector
- Connector Type = Connector Assembly
- Termination Method to Wire/Cable = IDC
- PCB Mount Retention = Without
- PCB Mount Alignment = Without
- [Connector Design](#) = Closed End
- Strain Relief = With
- Wire/Cable Type = Discrete Wire
- Sealed = No
- UL File Number = E28476
- CSA File Number = LR7189

Mechanical Attachment:

- Contact Retention = With
- Mating Retention Type = Locking Ramp
- [Panel Mount Retention](#) = Without
- Contact Retention Type = Locking Lance

Electrical Characteristics:

- Contact - Rated Current (A) = 7
- Operating Voltage Reference = AC
- Operating Voltage (VAC) = 600

Termination Features:

- Wire/Cable Size (mm²) = 0.8 - 0.9
- Wire/Cable Size (AWG) = 18

Housing Features:

- Connector Style = Receptacle
- Centerline (mm [in]) = 3.96 [0.156]
- Housing Style = Standard
- Housing Material = Nylon 6/6
- Housing Color = White
- [Mating Alignment](#) = With
- Mating Alignment Type = Polarizing Tab
- UL Flammability Rating = UL 94V-2

Configuration Features:

- [Number of Positions](#) = 5
- [Post Number\(s\) Omitted](#) = None
- [Backwall/Post Interruption\(s\)](#) = Without
- Number of Rows = 1

Industry Standards:

- [RoHS/ELV Compliance](#) = RoHS compliant, ELV compliant
- [Lead Free Solder Processes](#) = Not relevant for lead free process
- RoHS/ELV Compliance History = Always was RoHS compliant
- Agency/Standard = UL, CSA
- UL Rating = Recognized
- CSA Rating = Certified

Environmental:

- Operating Temperature (°C [°F]) = -55 - +105 [-67 - +221]

Conditions for Usage:

- [Applies To](#) = Wire/Cable

Body Features:

- Wire Type = Stranded
- Mating Retention = With
- Cable Exit Angle = 90°
- Underplate Material Thickness (μm [μin]) = 0.762 [30.000]
- Assembly Integration Feature = Without

Contact Features:

- Contact Type = Socket
- [Contact Base Material](#) = Copper Alloy
- [Contact Plating, Mating Area, Material](#) = Matte Tin
- Contact Layout = In-Line
- Multiple Contact Types = Without
- Contact Plating, Mating Area, Thickness (μm [μin]) = 2.03 - 5.08 [80 - 200]
- Underplate Material = Nickel

- Accepts Wire Insulation Diameter, Range (mm [in]) = 2.41 [0.095]
- For Use With = MTA .156 Header

Operation/Application:

- Application Use = Wire-to-Post

Packaging Features:

- Packaging Method = Bag
- Packaging Quantity = 250

Other:

- Brand = AMP
- Comment = Stripe may run down between ribs

THIS DRAWING IS UNPUBLISHED. RELEASED FOR PUBLICATION
 © COPYRIGHT - By - ALL RIGHTS RESERVED.

LOC		DIST		REVISIONS			
P	LTR	DESCRIPTION		DATE	DWN	APVD	
CM	00	J		REVISED PER ECO-12-007609	03AUG12	KH	SM

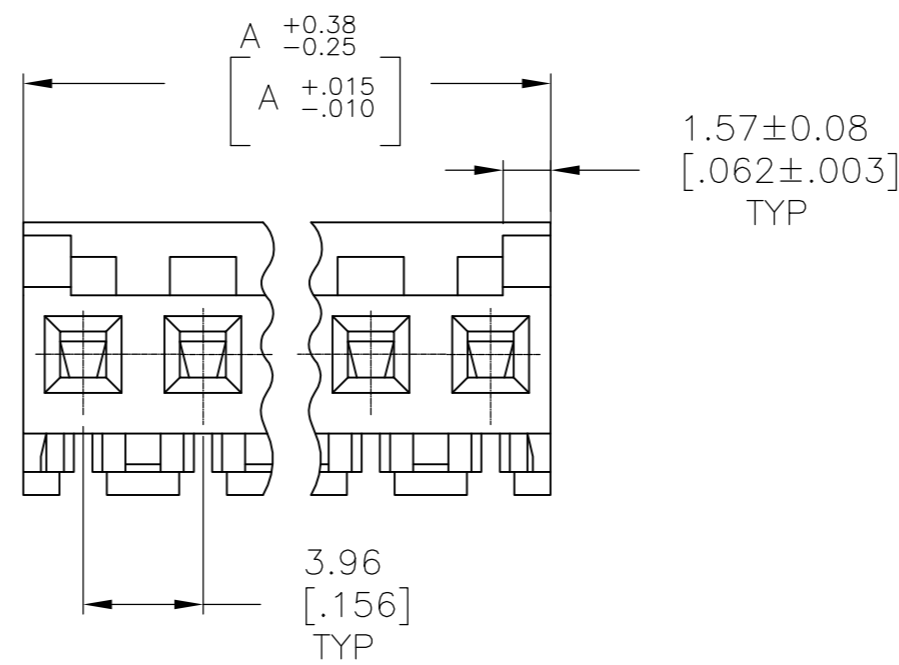
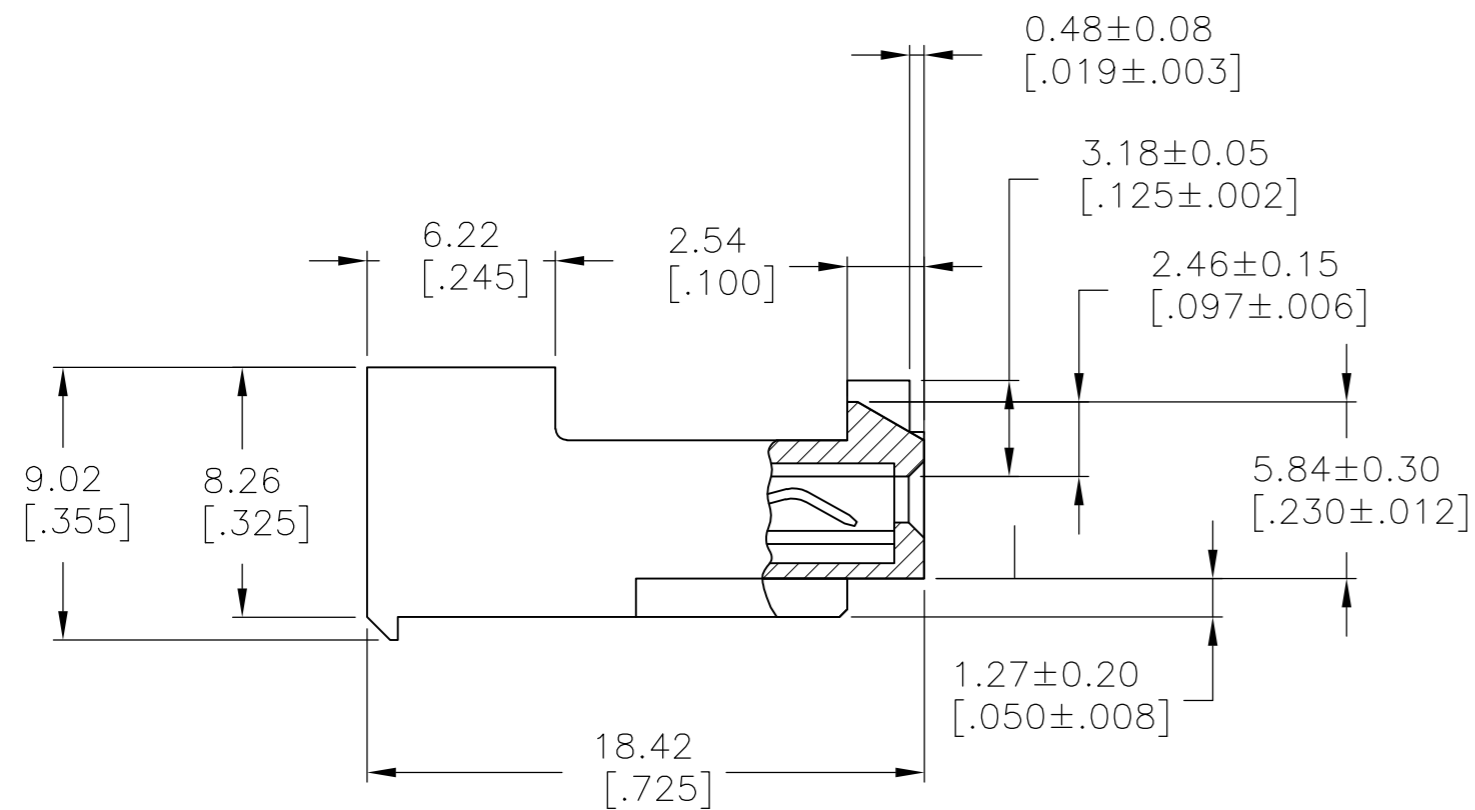
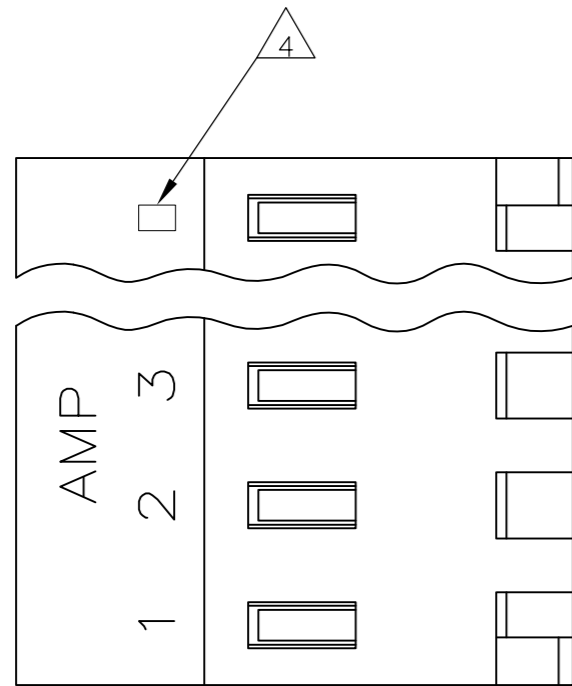

95.10[3.744]	24	5-643817-4
91.13[3.588]	23	5-643817-3
87.17[3.432]	22	5-643817-2
83.21[3.276]	21	5-643817-1
79.25[3.120]	20	5-643817-0
75.29[2.964]	19	4-643817-9
71.32[2.808]	18	4-643817-8
67.36[2.652]	17	4-643817-7
63.40[2.496]	16	4-643817-6
59.44[2.340]	15	4-643817-5
55.47[2.184]	14	4-643817-4
51.51[2.028]	13	4-643817-3
47.55[1.872]	12	4-643817-2
43.59[1.716]	11	4-643817-1
39.62[1.560]	10	4-643817-0
35.66[1.404]	9	3-643817-9
31.70[1.248]	8	3-643817-8
27.74[1.092]	7	3-643817-7
23.77[.936]	6	3-643817-6
19.81[.780]	5	3-643817-5
15.85[.624]	4	3-643817-4
11.89[.468]	3	3-643817-3
7.92[.312]	2	3-643817-2
95.10[3.744]	24	2-643817-4
91.13[3.588]	23	2-643817-3
87.17[3.432]	22	2-643817-2
83.21[3.276]	21	2-643817-1
79.25[3.120]	20	2-643817-0
75.29[2.964]	19	1-643817-9
71.32[2.808]	18	1-643817-8
67.36[2.652]	17	1-643817-7
63.40[2.496]	16	1-643817-6
59.44[2.340]	15	1-643817-5
55.47[2.184]	14	1-643817-4
51.51[2.028]	13	1-643817-3
47.55[1.872]	12	1-643817-2
43.59[1.716]	11	1-643817-1
39.62[1.560]	10	1-643817-0
35.66[1.404]	9	643817-9
31.70[1.248]	8	643817-8
27.74[1.092]	7	643817-7
23.77[.936]	6	643817-6
19.81[.780]	5	643817-5
15.85[.624]	4	643817-4
11.89[.468]	3	643817-3
7.92[.312]	2	643817-2
DIM A	NO. OF CIRCUITS	PART NO.

- △ SUPERSEDED BY 5-643817-4
- △ SUPERSEDED BY 5-643817-3
- △ SUPERSEDED BY 5-643817-2
- △ SUPERSEDED BY 5-643817-1
- △ SUPERSEDED BY 4-643817-9
- △ SUPERSEDED BY 4-643817-7

- 1 MATERIAL: CONNECTOR - NYLON UL94-V2
CONTACTS - 0.30 [.012] THICK COPPER ALLOY
(BRIGHT TIN-LEAD 0.00203 [.000080] MIN. THICK
FOR CONTACTS 643817-2 THRU 2-643817-4).
(MATTE WHISKER MITIGATED TIN 0.00203 [.000080] MIN. THICK
FOR CONTACTS 3-643817-2 THRU 5-643817-4).
- 2 CONTACTS ACCEPT 18 AWG WIRE WITH 2.41 [.095] MAX
INSULATION DIAMETER.
- 3 CONTACTS MUST ACCEPT 1.14±0.03 [.045±.001]
POST AND REMAIN LOCKED IN POSITION.
- 4 IDENTIFICATION NUMBER FOR LAST CIRCUIT MAY
NOT APPEAR ON ALL ASSEMBLIES.
- 5 DIMENSIONS IN BRACKETS ARE IN INCHES.
- 6 HOUSING FEATURES ARE: CLOSED END WITH LOCKING
RAMP AND POLARIZING TAB.
- 7 OBSOLETE PARTS: OBSOLETE CIS STREAMLINING PER D.RENAUD/D.SINISI
- 8 ORANGE COLOR STRIPE ON HOUSING (NOT SHOWN) MAY RUN DOWN BETWEEN RIBS.

METRIC

THIS DRAWING IS A CONTROLLED DOCUMENT.		DWN S. CARPENTER 09JUL2003		
DIMENSIONS: mm [INCHES]		CHK D. BOSSI 09JUL2003		
TOLERANCES UNLESS OTHERWISE SPECIFIED:		APVD D. BOSSI 09JUL2003	NAME	
0 PLC ± -		PRODUCT SPEC	MTA 156 CONNECTOR ASSEMBLY, 18 AWG, STANDARD	
1 PLC ± -		APPLICATION SPEC	SIZE	CAGE CODE
2 PLC ± -		114-1020	A2	00779
3 PLC ± 0.13 [.005]		WEIGHT	DRAWING NO	
4 PLC ± -		-	C=643817	
4 PLC ANGLES ± -		CUSTOMER DRAWING	SCALE	SHEET
FINISH		1	4:1	1 OF 1
MATERIAL		1	REV	J