

2.8 mm Blind Mate Connectors (Continued)

Bulkhead Jack

Material and Finishes

Center Contact — Beryllium copper, gold plated

Inner Shell — Beryllium copper, gold plated

Dielectric — TEFLON

Grip Ring — Beryllium copper or brass, nickel plated

Shroud — Beryllium copper, gold plated

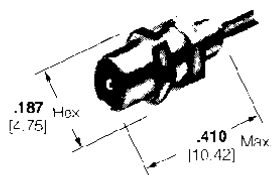

.047 [1.19] Semi-Rigid Cable - Part No. 413024-1

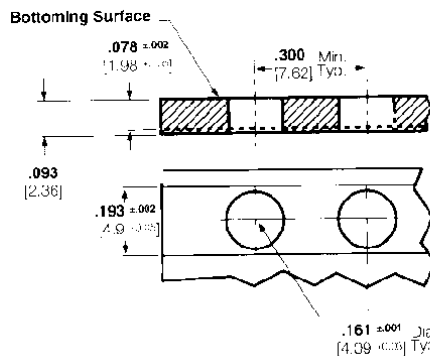

Recommended Panel Layout

Launcher

Materials and Finishes

Center Contact — Brass, gold plated

Inner Shell — Beryllium copper, gold plated

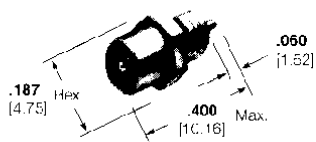

Part No. 413020-1

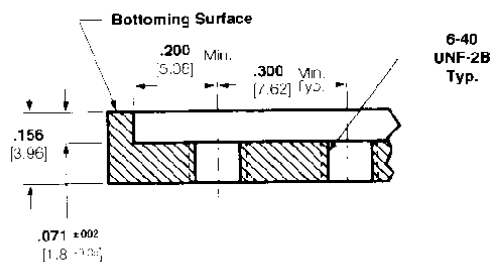

Recommended Panel Layout

6-40
UNF-2B
Typ.

Blind Mate Connectors

Plug

Materials and Finishes

Shroud and Grip Ring — Brass, nickel plated

Retaining Clip — Beryllium copper, gold plated

Shell and Contact — Beryllium copper, gold plated

Dielectric — TEFLON

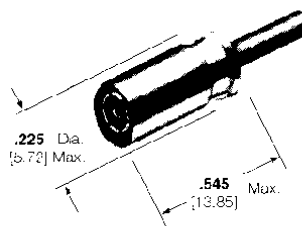

RG-405 Semi-Rigid/.086 Cable
Part No. 413242-1

Jack

Materials and Finishes

Sleeve and Grip Ring — Brass, nickel plated

Retaining Clip — Beryllium copper, nickel plated

Shell and Contact — Beryllium copper, gold plated

Dielectric — TEFLON

Application Tool — 59980-1

(Requires Die Set and Locator, see table for part numbers)

Trimmer Tool — 312317-1

Cable Dressing Fixture — 311395-1

Note: All the above tools are included in Hand Tool Kit No. 59981-1 (see table)

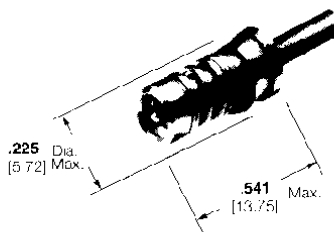

RG-405 Semi-Rigid/.086 Cable
Part No. 413249-1

Connector Cable Range Selection Code†	RG/U Cable	Connector Configuration	Part No.	Hand Tool Kit No. 59981-1	
				Die Set	Locator*
P	405 Semi-Rigid .086 [2.1E]	Plug Jack	413242-1 413249-1	312253-2 312253-2	852113-1 852114-1

†Refer to pages 14 and 15 for code specifications.

*Not included in Hand Tool Kit No. 59981-1; must be purchased separately.