

4  
DRAWING MADE IN THIRD ANGLE PROJECTION

THIS DRAWING IS UNPUBLISHED. RELEASED FOR PUBLICATION  
 © COPYRIGHT 1965 BY AMP INCORPORATED, HARRISBURG, PA. ALL INTERNATIONAL RIGHTS RESERVED. AMP PRODUCTS MAY BE COVERED BY U.S. AND FOREIGN PATENTS AND/OR PATENTS PENDING.

LOC	DIST	REVISIONS						
AF	50	P	F	ZONE	LTR	DESCRIPTION	DATE	APPROVED
					N	REV PER 0012-93	3/1/83	JR/CM

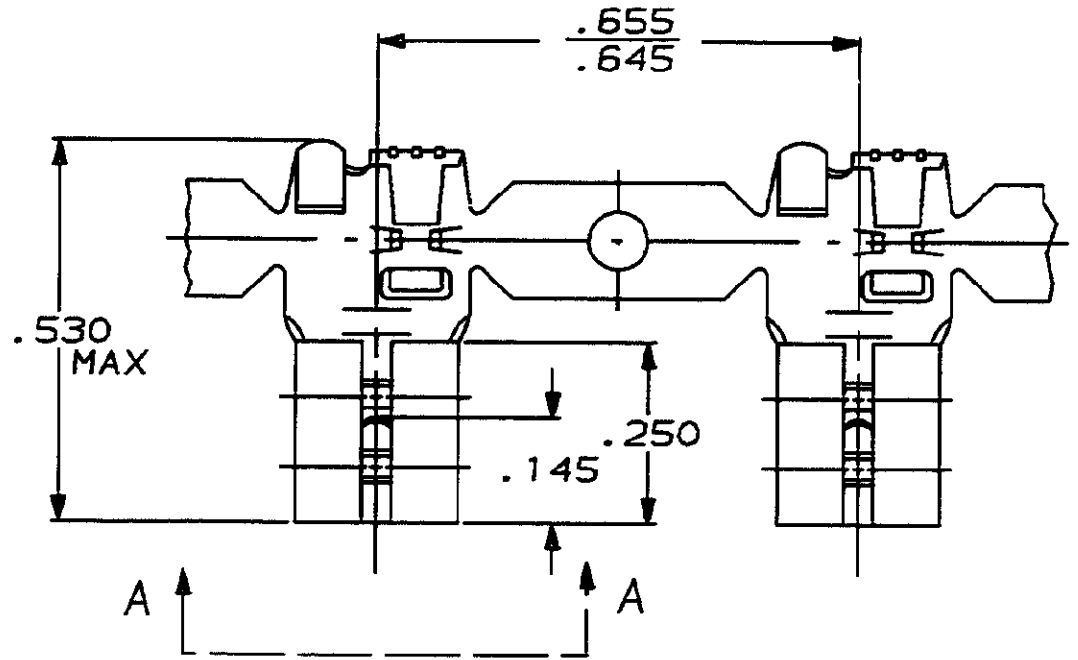

1- CONTINUOUS STRIP ON REELS.

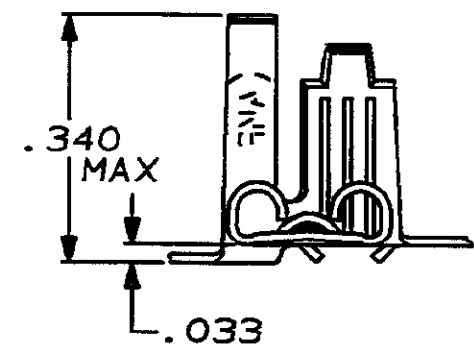
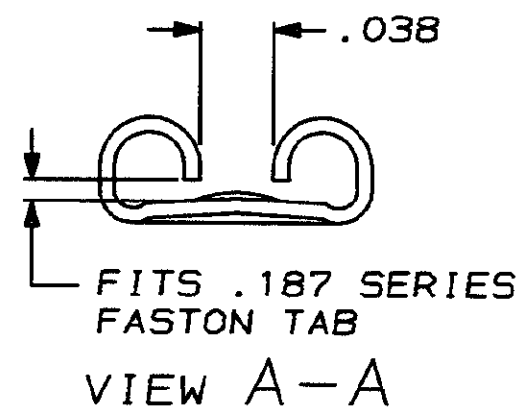

.110-.170	20-16	.020 ±.001	SILVER	.012 BRASS	42486-4
.110-.170	20-16	.020 ±.001	NICKEL	.012 STEEL	42486-3
.110-.170	20-16	.020 ±.001	TIN	.012 BRASS	42486-2
.110-.170	20-16	.020 ±.001	—	.012 BRASS	42486-1
INSUL RANGE	WIRE SIZE	TAB THK	FINISH	MATERIAL	PART NO

UNLESS OTHERWISE SPECIFIED DIMENSIONS ARE IN INCHES TOLERANCES ON: 2 PL DEC ± _____ 3 PL DEC ± .015 ANGLES ± _____	DR 2/7/86	<b>AMP</b>   AMP INCORPORATED Harrisburg, Pa. 17105	
	JR RUTH		
MATERIAL SEE ABOVE	CHK 2/7/86	NAME .187 SERIES FLAG FASTON RECEPTACLE	
	6 YETTER		
FINISH SEE ABOVE	APPD 2/7/86	SIZE	FSCM NO
	C MEYERS	<b>B</b>	00779
	APPD 2/7/86	DRAWING NO	42486
	R KUZD	SCALE	NTS
	PRODUCT SPEC	SHEET	1 OF 1
	APPLICATION SPEC		
	WEIGHT		