

THIS DRAWING IS UNPUBLISHED. RELEASED FOR PUBLICATION
 © COPYRIGHT - By - ALL RIGHTS RESERVED.

LOC	DIST	REVISIONS					
AF	50	P	LTR	DESCRIPTION	DATE	DWN	APVD
		D		REVISED PER ECR-13-004343	30JUL13	KH	KR

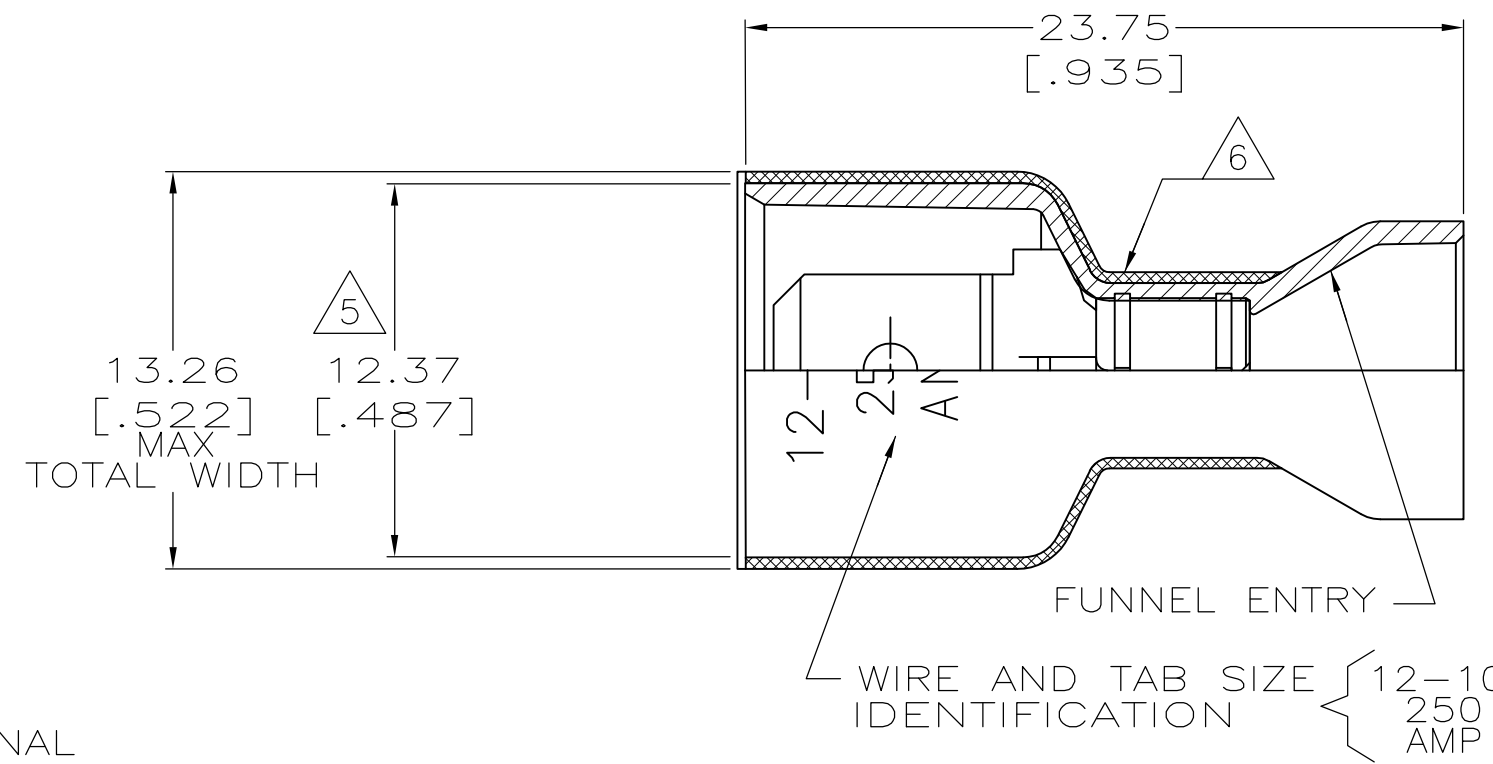

- 1 TAB DIMENSIONS 0.81±0.025 X 6.35 [.032±.001 X .250]
- 2 WIRE STRIP LENGTH 7.92 [.312].
- 3 INSULATION SIZE .320 MAX DIA.
- 4 SUPPLIED IN LOOSE PIECE.
- 5 DIMENSION DOES NOT INCLUDE TRIM BURR.
- 6 0.38 [.015] MAX CARRIER TRIM BURR PER SIDE IS ALLOWABLE IN THE SHADED AREA.

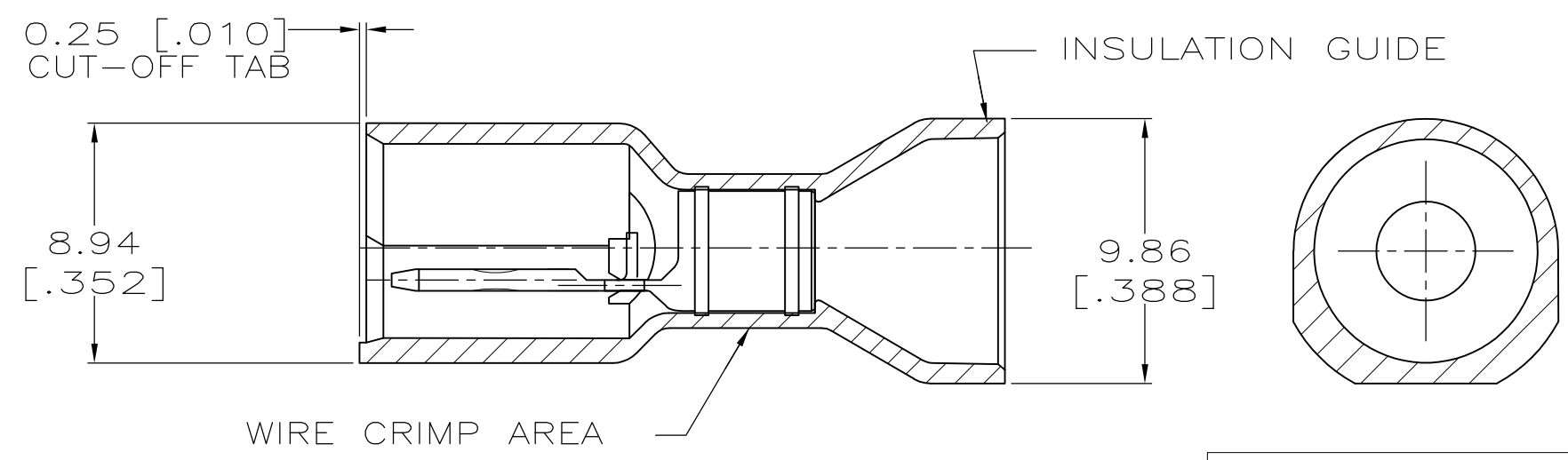
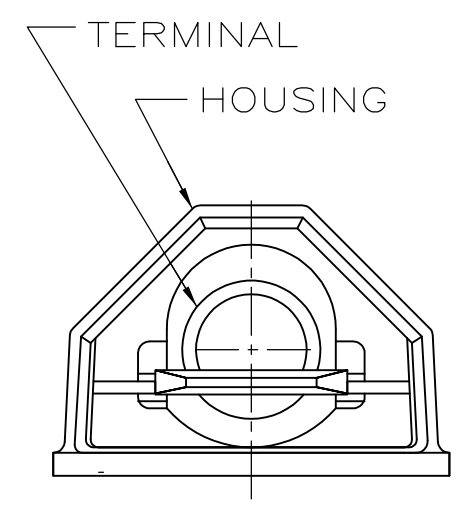

HOUSING: NYLON,COLOR-YELLOW TAB: BRASS,TIN	4-521098-2
MATERIAL & FINISH	PART NO

THIS DRAWING IS A CONTROLLED DOCUMENT.		DWN	JR RUTH	9/25/95	TE Connectivity NAME TAB ASSEMBLY, ULTRA-FAST, [6.35] .250 SERIES, 12-10 AWG								
DIMENSIONS: mm [INCHES]		CHK	P FORTNEY	9/25/95									
TOLERANCES UNLESS OTHERWISE SPECIFIED:		APVD	D BRATINA	9/25/95									
0 PLC ± - 1 PLC ± - 2 PLC ± 0.38 [.015] 3 PLC ± - 4 PLC ± - ANGLES ± -		PRODUCT SPEC	108-2017										
MATERIAL	SEE TABLE	FINISH	SEE TABLE	APPLICATION SPEC	114-2123	SIZE	A3	CAGE CODE	00779	DRAWING NO	C-521098	RESTRICTED TO	-
CUSTOMER DRAWING				WEIGHT	-	SCALE		4:1	SHEET		1 OF 1	REV	D