

Distributed by:

**JAMECO**<sup>®</sup>  
ELECTRONICS

**www.Jameco.com ♦ 1-800-831-4242**

The content and copyrights of the attached  
material are the property of its owner.

Jameco Part Number 753096

- 1 .00076[.000030] GOLD IN THE CONTACT AREA, .00254[.000100]-.00508[.000200] MATTE TIN-LEAD ON THE SOLDER TAIL, ALL OVER .00127[.000050] NICKEL
- 2 POINT OF MEASUREMENT FOR PLATING THICKNESS
- 3 THE NOTED DIMENSIONS APPLY FROM THE BASIC DIMENSION LINE (NOT THE POST CENTERLINE) TO THE SURFACE INDICATED
- 4 ON ASSEMBLIES WITH FOUR OR MORE POSITIONS, TWO POLARIZATION SLOTS.  
ON ASSEMBLIES WITH TWO OR THREE POSITIONS, ONE POLARIZATION SLOT.
- 5 DIMENSIONS NOTED ARE FOR SOLDER STENCIL LAYOUT FOR USE WITH A 1.57±0.20 [.062±.008] THICK PRINTED CIRCUIT BOARD
- 6 MATERIAL: HOUSING - HIGH TEMPERATURE THERMOPLASTIC  
COLOR: BLACK  
POSTS - BRASS
- 7 .00076[.000030] GOLD IN THE CONTACT AREA, .00254[.000100]-.00508[.000200] MATTE TIN ON THE SOLDER TAIL, ALL OVER .00127[.000050] NICKEL

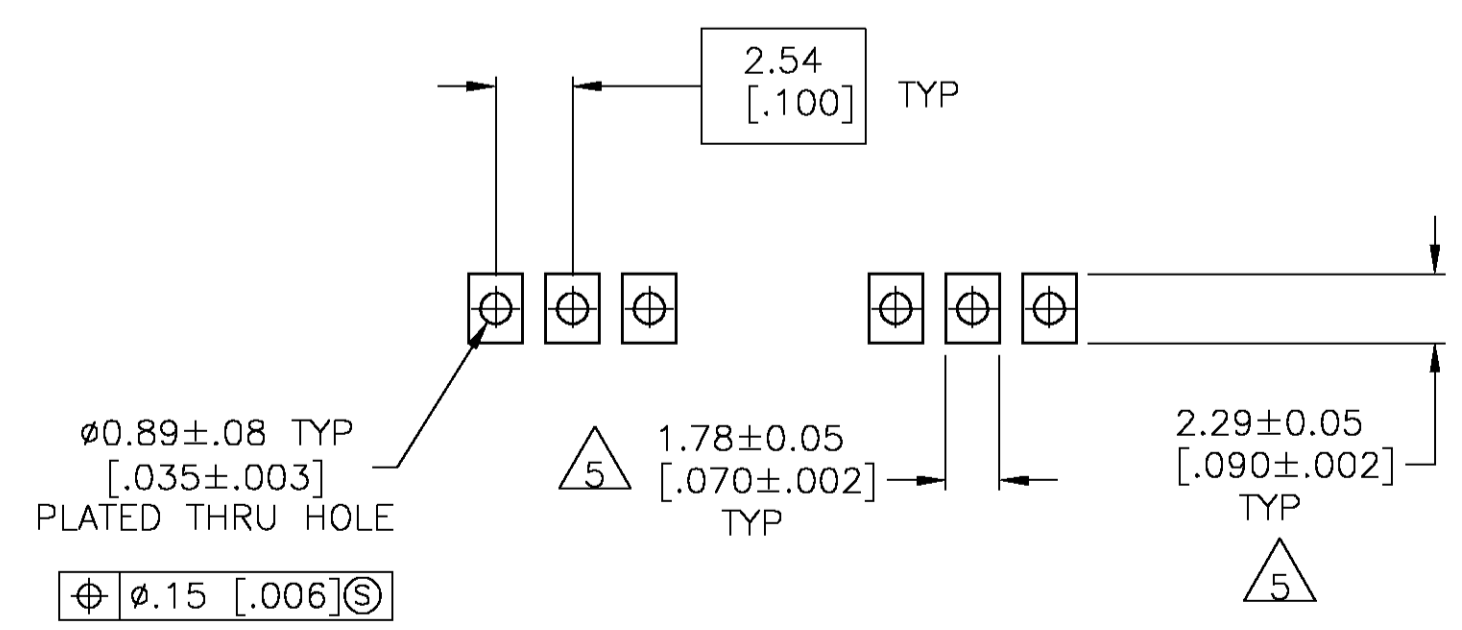
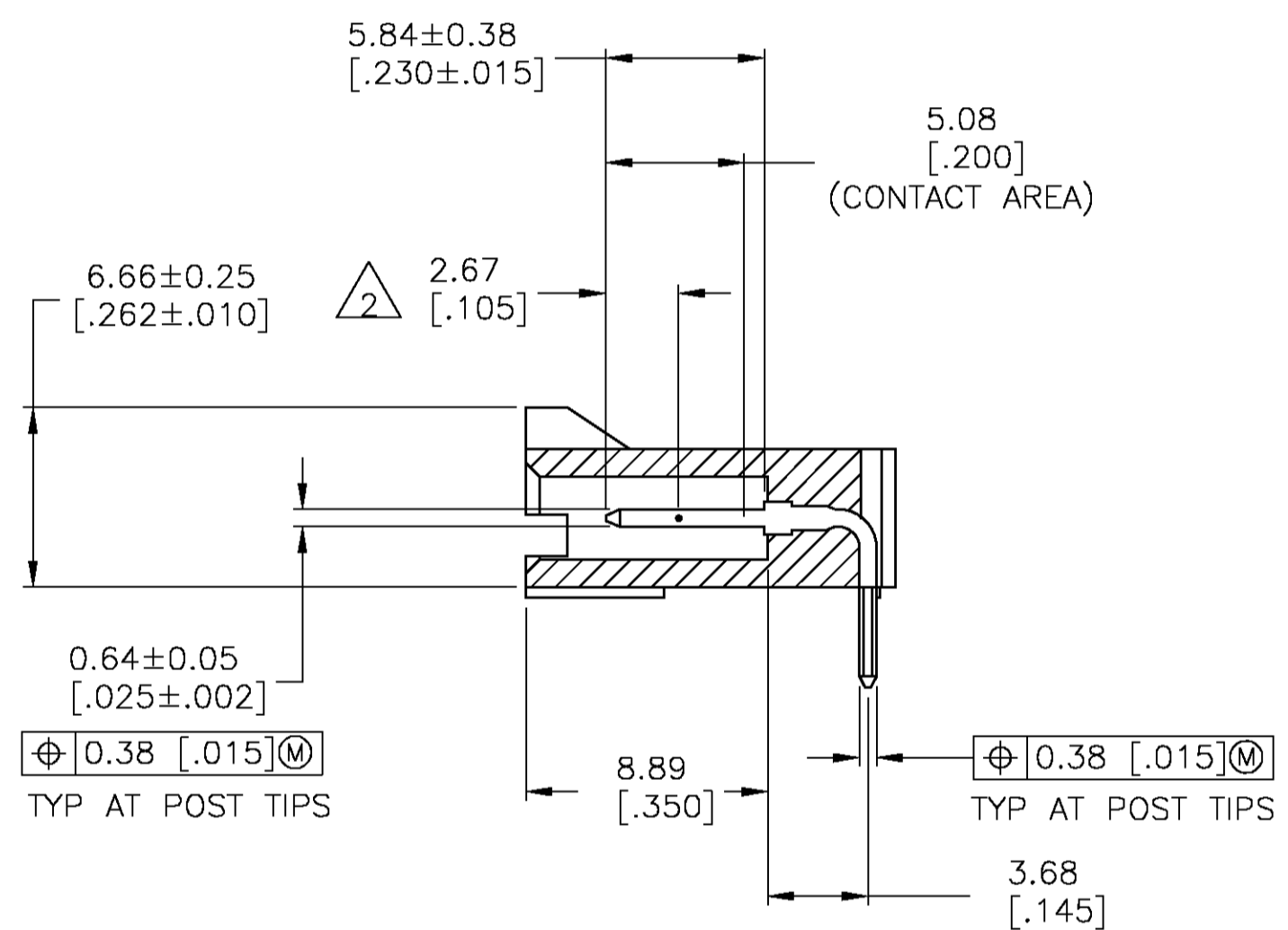
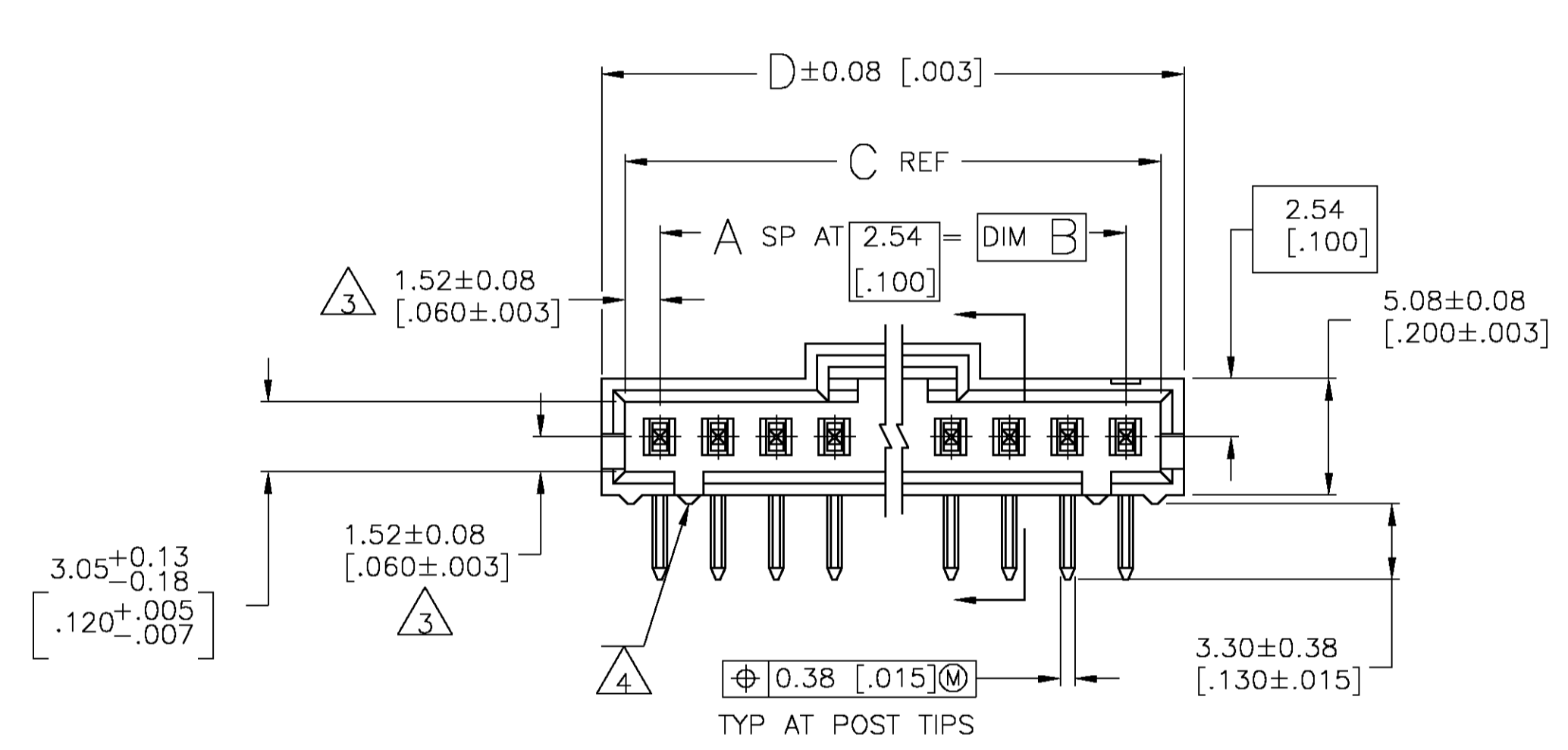
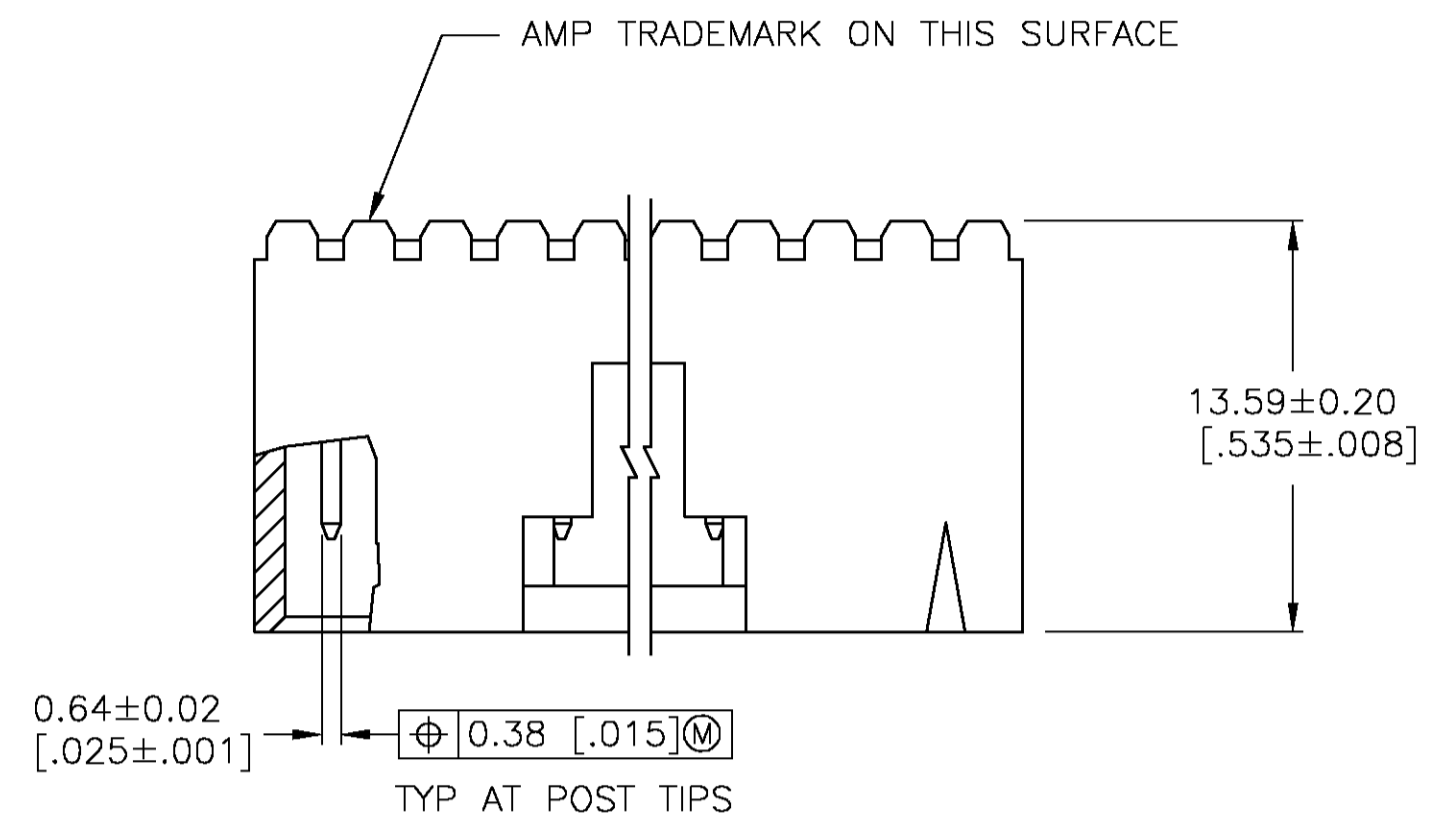

RECOMMENDED PC BOARD MOUNTING DIMENSIONS  
 RECOMMENDED STENCIL THICKNESS = 0.25 [.010]

PLATING	D	C	B	A	NO OF POSN	PART NUMBER
7	2.600	2.520	2.400	24	25	7-104935-4
7	2.500	2.420	2.300	23	24	7-104935-3
7	2.400	2.320	2.200	22	23	7-104935-2
7	2.300	2.220	2.100	21	22	7-104935-1
7	2.200	2.120	2.000	20	21	7-104935-0
7	2.100	2.020	1.900	19	20	6-104935-9
7	2.000	1.920	1.800	18	19	6-104935-8
7	1.900	1.820	1.700	17	18	6-104935-7
7	1.800	1.720	1.600	16	17	6-104935-6
7	1.700	1.620	1.500	15	16	6-104935-5
7	1.600	1.520	1.400	14	15	6-104935-4
7	1.500	1.420	1.300	13	14	6-104935-3
7	1.400	1.320	1.200	12	13	6-104935-2
7	1.200	1.120	1.000	10	11	6-104935-1
7	1.100	1.020	.900	9	10	6-104935-0
7	1.000	.920	.800	8	9	5-104935-9
7	.800	.720	.600	6	7	5-104935-8
7	.700	.620	.500	5	6	5-104935-7
7	.600	.520	.400	4	5	5-104935-6
7	7.62 [.300]	5.59 [.220]	2.54 [.100]	1	2	5-104935-5
	33.02 [1.300]	30.99 [1.220]	27.94 [1.100]	11	12	5-104935-4
	10.16 [.400]	8.13 [.320]	5.08 [.200]	2	3	5-104935-3
	22.86 [.900]	20.83 [.820]	17.78 [.700]	7	8	5-104935-2
	12.70 [.500]	10.67 [.420]	7.62 [.300]	3	4	5-104935-1
1	7.62 [.300]	5.59 [.220]	2.54 [.100]	1	2	104935-5
	33.02 [1.300]	30.99 [1.220]	27.94 [1.100]	11	12	104935-4
	10.16 [.400]	8.13 [.320]	5.08 [.200]	2	3	104935-3
	22.86 [.900]	20.83 [.820]	17.78 [.700]	7	8	104935-2
	12.70 [.500]	10.67 [.420]	7.62 [.300]	3	4	104935-1

THIS DRAWING IS A CONTROLLED DOCUMENT.

DMN E. BRANDBERG 27-JUL-95	Tyco Electronics Corporation Harrisburg, Pa 17105-3608
CHK J. GESFORD 27-JUL-95	
APVD D. DUPLER 27-JUL-95	NAME HEADER ASSY, AMPMODU MTE, RIGHT ANGLE, SINGLE ROW, .100CL, .025 SQ POSTS, WITH LATCH
DIMENSIONS: mm [INCHES]	TOLERANCES UNLESS OTHERWISE SPECIFIED: 0 PLC ± - 1 PLC ± - 2 PLC ± - 3 PLC ± .005 4 PLC ± - ANGLES ± -
MATERIAL 6	FINISH POST : SEE TABLE
SIZE A1	CAGE CODE 00779
WEIGHT -	DRAWING NO 104935
CUSTOMER DRAWING	RESTRICTED TO
SCALE 4:1	SHEET 1 OF 1
	REV F