



All numerical values are in metric units [with U.S. customary units in brackets]. Dimensions are in millimeters. Unless otherwise specified, dimensions have a tolerance of ± 0.13 and angles have a tolerance of $\pm 2^\circ$. Figures and illustrations are for identification only and are not drawn to scale.

1. INTRODUCTION

This specification covers the requirement for application of the Z-PACK HS3 and HS3 Plus 6- and 10-Row Connectors. These connectors significantly reduce signal crosstalk in high speed, sub-nanosecond applications through the use of a ground plane between each column of signal contacts. The system consists of 50 ohm controlled impedance connectors with 2.5 mm signal column spacing.

The Z-PACK HS3 and HS3 Plus Connectors are available in modular right-angle receptacles, and vertical pin headers. HS3 Plus is “backwards” compatible with HS3. Both receptacles and pin headers are available with compliant pin only and are shipped in 50 and 100 signal position (10-row) modules, or 30- and 60-position (6-row) modules which the customer joins together on the printed circuit (pc) board for the correct size.

When corresponding with TE Connectivity Personnel, use the terminology provided in this specification to help facilitate your inquiry for information. Basic terms and features of components are provided in Figure 1.

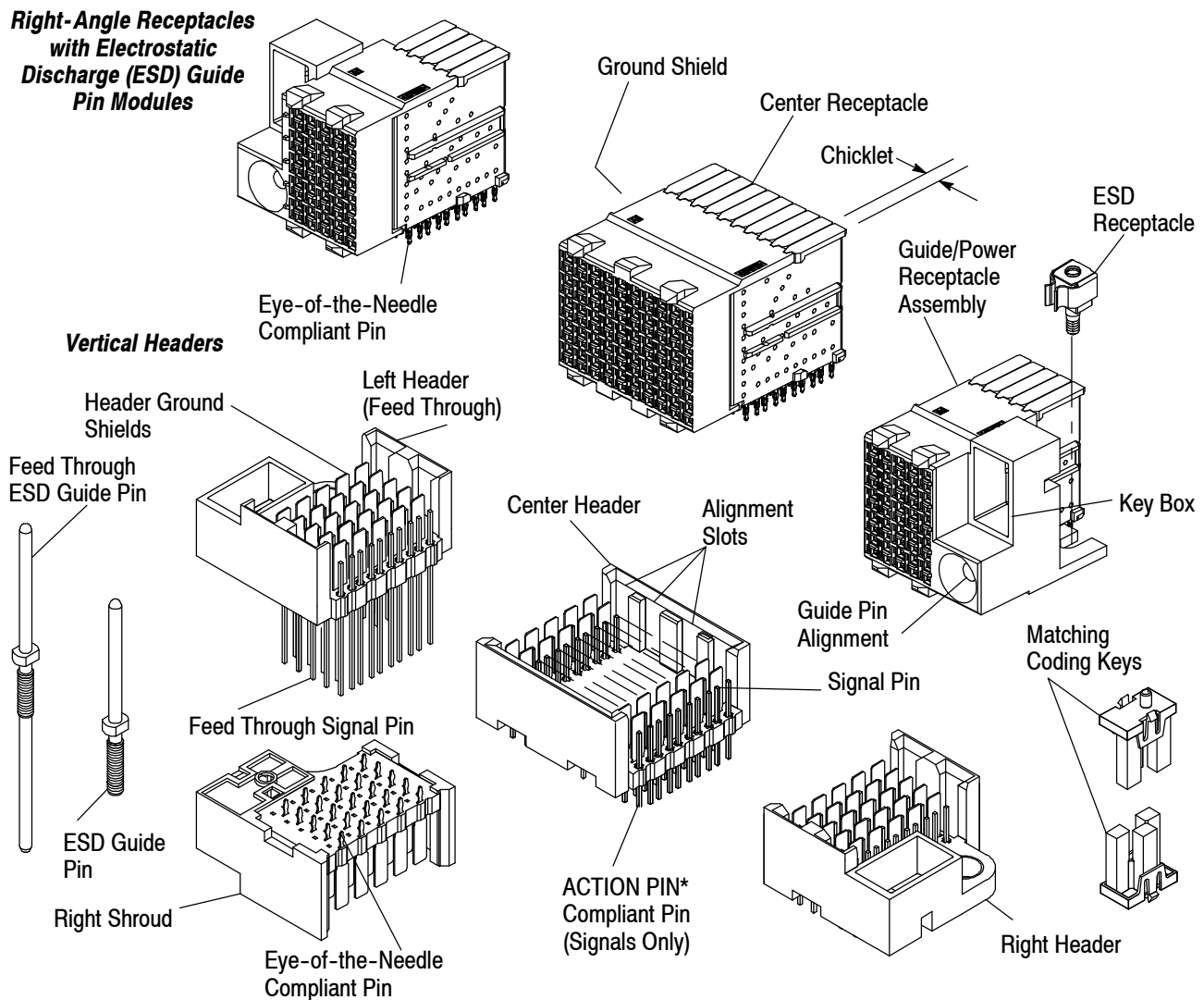

Figure 1 (cont'd)

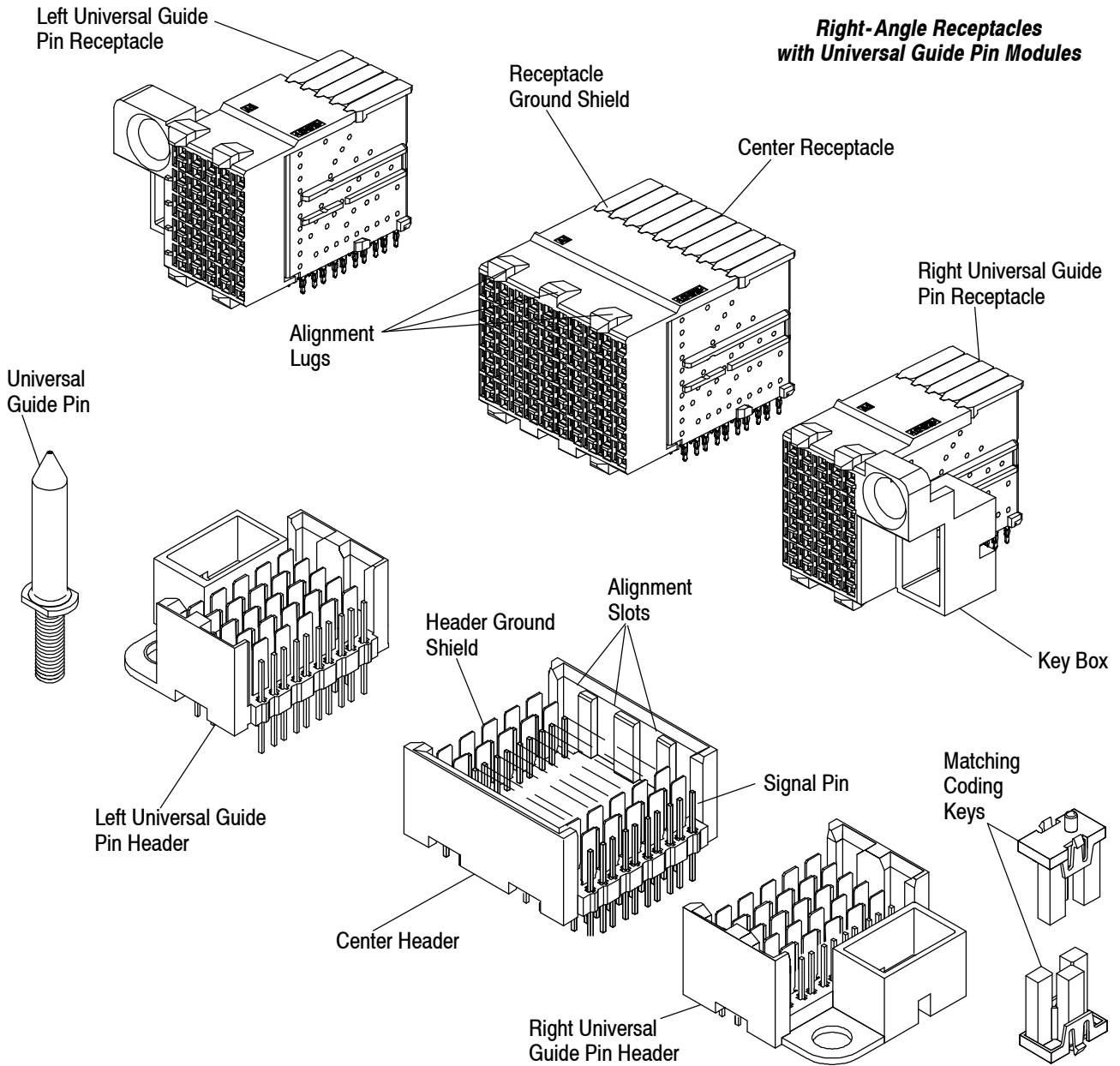

Figure 1 (end)

2. REFERENCE MATERIAL

2.1. Revision Summary

- Updated document to corporate requirements
- Changed “B” Nominal dimension in table in Figure 7

2.2. Customer Assistance

Reference Product Base Part numbers 5120658, 5120790 and Product Code 2957 are representative numbers of Z-PACK HS3 and HS3 Plus 6- and 10-Row Connectors. Use of these numbers will identify the product line and help you obtain product and tooling information. Such information can be obtained through a local TE Representative or, by visiting our website at www.te.com, or by calling PRODUCT INFORMATION or the TOOLING ASSISTANCE CENTER at the numbers at the bottom of page 1.

2.3. Drawings

Customer Drawings for specific products are available from the service network. The information contained in Customer Drawings takes priority if there is a conflict with this specification or with any other technical documentation supplied by TE.

2.4. Report

TE Electrical Performance Reports, 1308505 (6-Row) and 1308506 (10-Row), are available from TE and provide important information on signal integrity performance of Z-PACK HS3 Connectors under a variety of circumstances.

2.5. Specifications

Product Specification 108-1957 is available to provide test and performance results.

2.6. Instructional Material

The following list includes available instruction sheets (408-series) that provide assembly procedures for product, operation, maintenance and repair of tooling, as well as setup and operation procedures of applicators; and customer manuals (409-series) that provide setup, operation, and maintenance of machines.

| <u>Document Number</u> | <u>Document Title</u> |
|------------------------|---|
| 408-2636-1 | CERTI-LOK* Insertion Tool 380392-8 |
| 408-4546 | Seating Tools 91312-[] and 91313-[] for Z-PACK HS3 Backplane Headers |
| 408-4573 | Ground Blade Repair Kits 1320534-1, -2 for Z-PACK HS3 6- and 10-Row Headers |
| 408-8393 | Receptacle Housing Removal Tool 1338744-[] |
| 408-8394 | Receptacle Seating Tools 1338742-[], and 1338743-[] |
| 408-8410 | Chicklet Extraction Tools 1338745-1 and 1338746-1 |
| 408-9979 | Pin Repair Kits 354687-1, -2, and -3 for Z-PACK Signal Pin Contacts |

3. REQUIREMENTS

3.1. Storage

The connectors should remain in the shipping containers until ready for use to prevent deformation to the contacts. The connectors should be used on a first in, first out basis to avoid storage contamination that could adversely affect signal transmissions.

3.2. Product Materials and Selection Criteria

A. Material

All Z-PACK HS3 and HS3 Plus Dual Connector housings and chicklets are molded of high temperature liquid crystal polymer (LCP) thermoplastic, UL94V-O rated.

All contacts are copper alloy and plated at the contact interface with gold or gold flash over palladium-nickel. All contacts have a nickel underplate and tin or tin-lead plated compliant tails.

B. Size

Typical connector sizes and length of pins are shown in Figure 2.

C. Guides

The pin headers have alignment slots with a guide-in feature that helps position the pin and receptacle contacts prior to engagement of the circuits. See Figure 1.

**30-Position
(6-Row)**

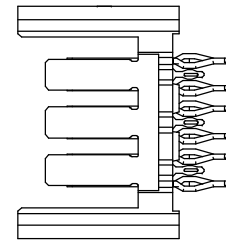
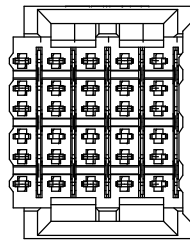
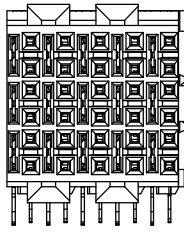

**60-Position
(6-Row)**

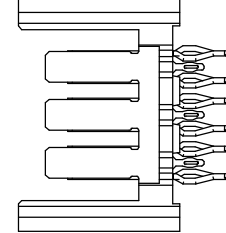
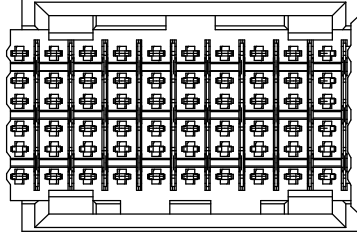
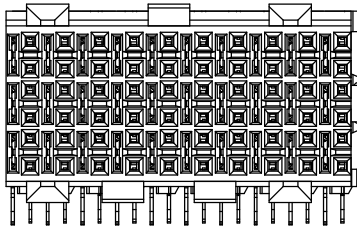

**50-Position
(10-Row)**

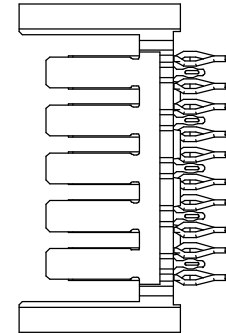
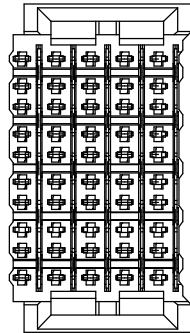
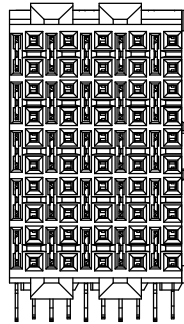

**100-Position
(10-Row)**

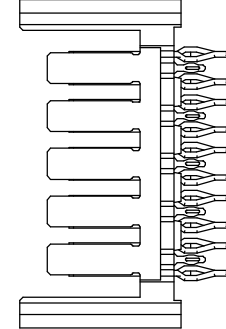
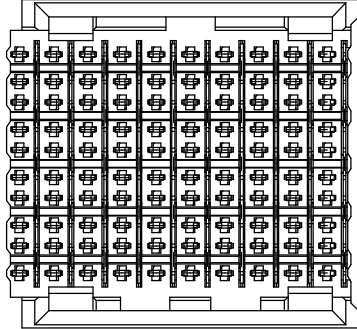
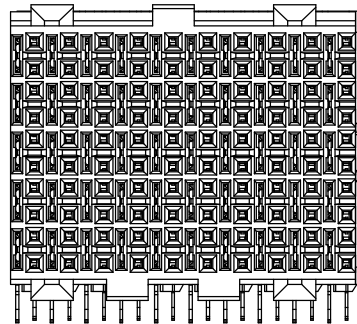

**HS3 Plus
60-Position
(6-Row)**

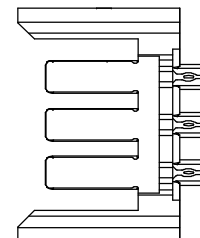
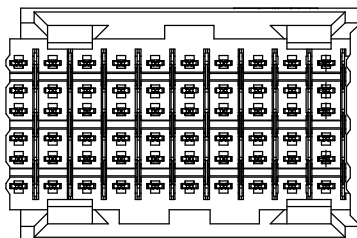
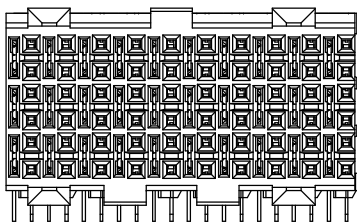

Figure 2 (cont'd)

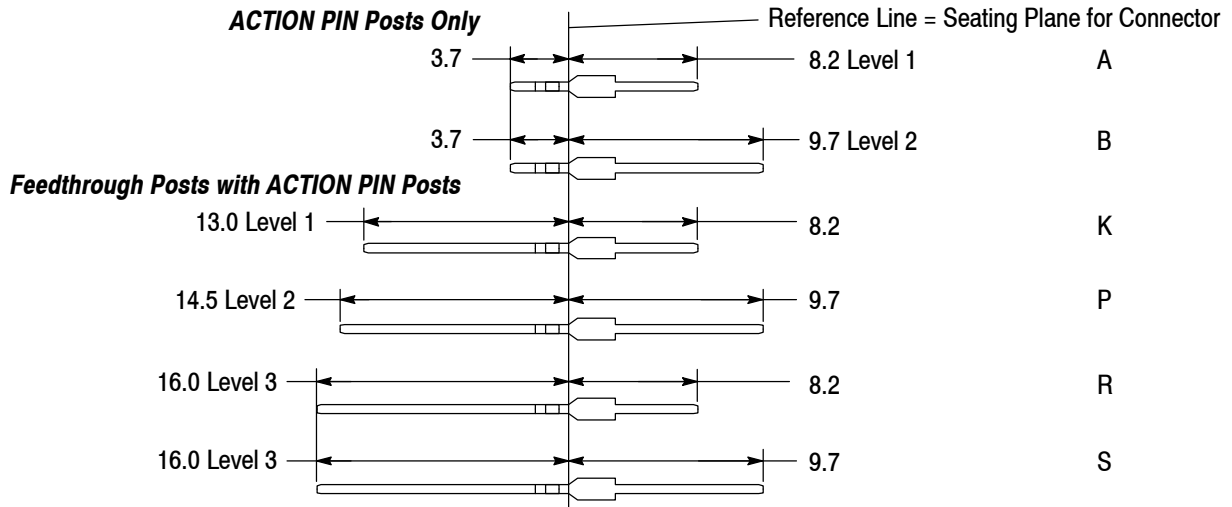
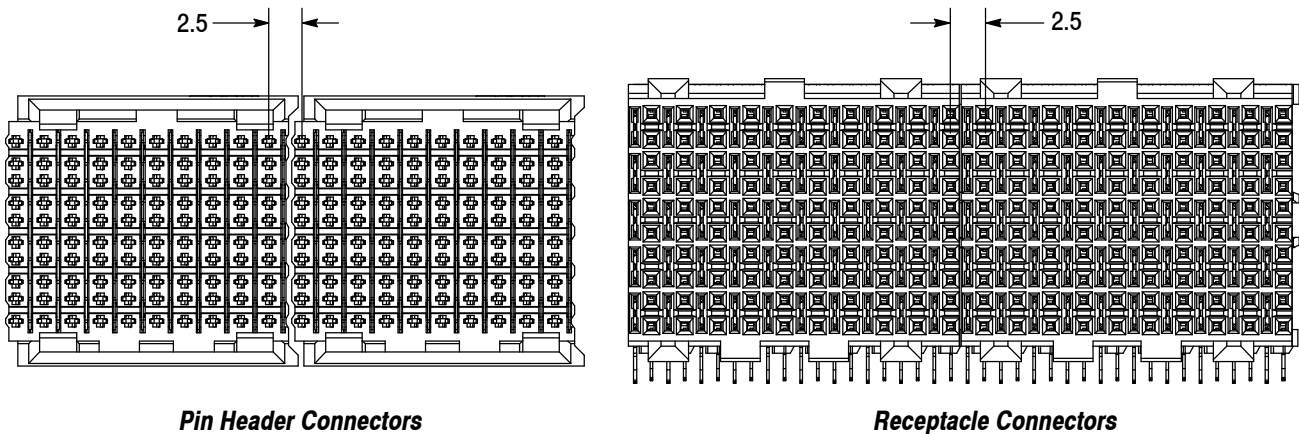

Figure 2 (end)

D. End-to-End Placement

The end contacts in the pin header and receptacle are one half the contact spacing distance from the ends of the housing. This design feature makes it possible to mount connectors end-to-end while maintaining the 2.5 mm column spacing. Connectors can be mounted end-to-end within the specified dimension. See Figure 3.



NOTE: 10-row shown, 6-row is the same for dimensioning purposes.

Figure 3

3.3. Alignment

Proper alignment is essential to ensure full engagement of mating connectors, and to ensure that contacts are not bent or otherwise damaged during mating and unmating. For tolerance limitations, see Figure 4.

NOTE: 6-row shown, 10-row is the same for dimensioning purposes.

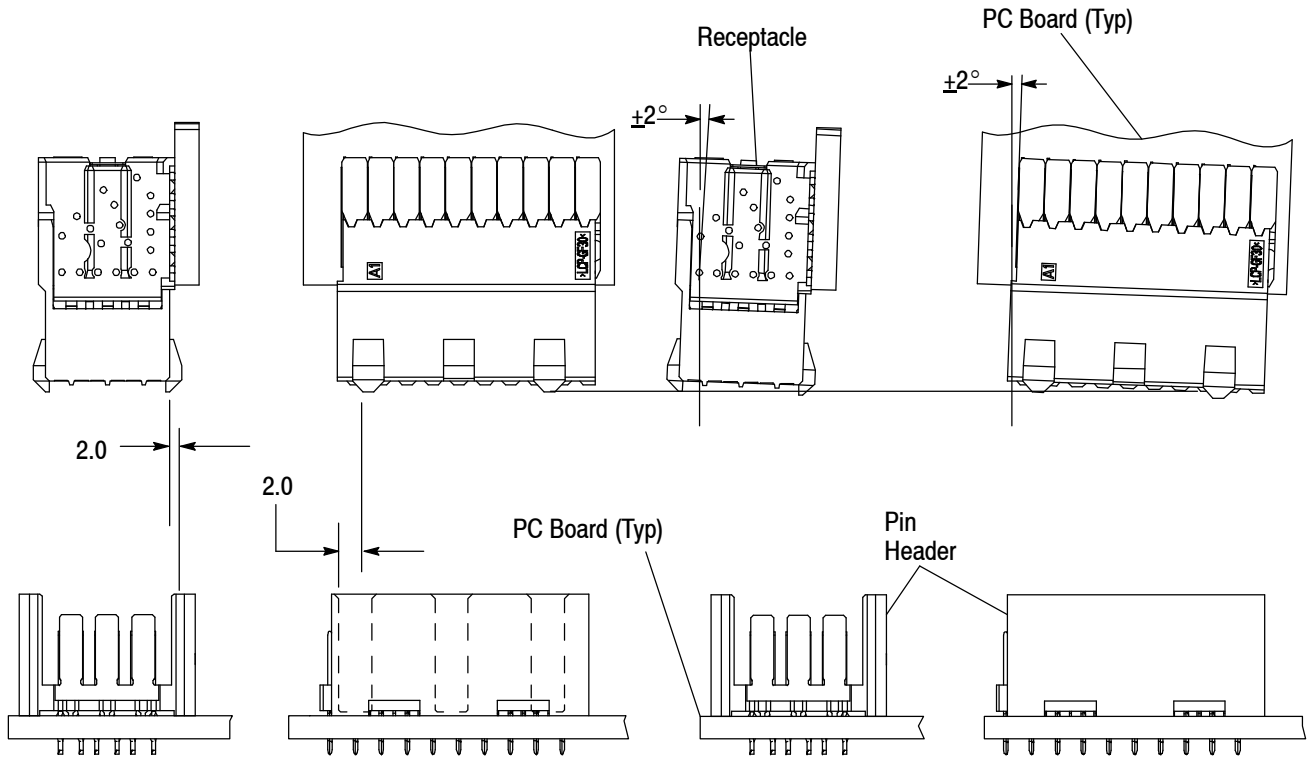

Figure 4

3.4. Mating Dimension

Full mating of connectors is necessary to ensure a good connection. The dimension from the surface of the pc board to which the pin header is mounted and the first row of contacts in the receptacle must be as shown in Figure 5.

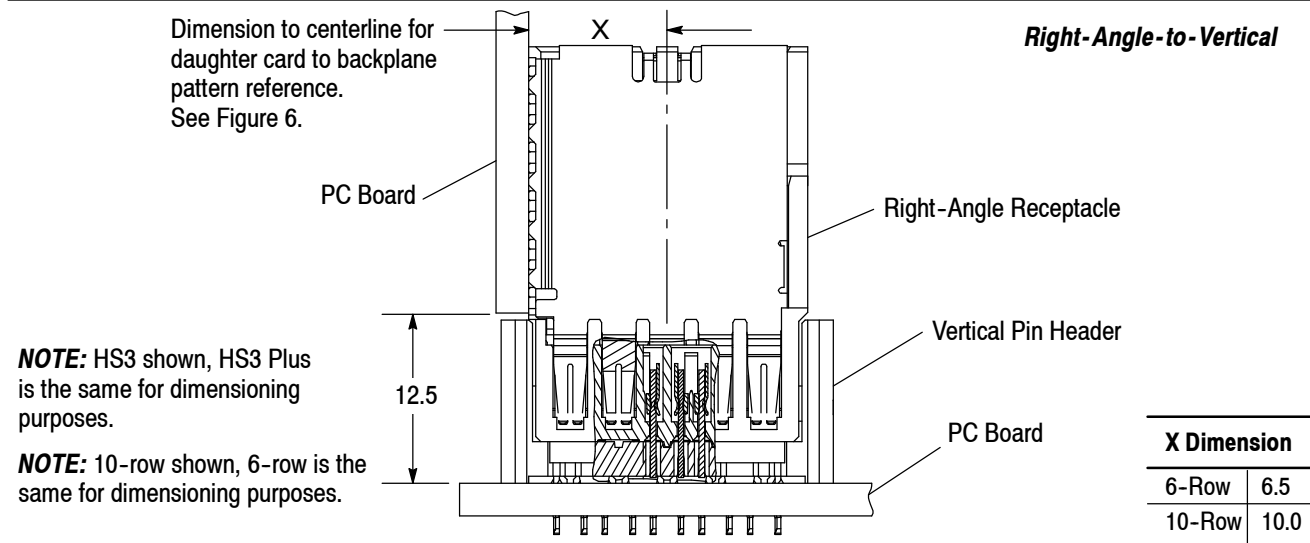

Figure 5

3.5. PC Board Requirements

A. PC Board Thickness

Right-angle receptacle connectors with compliant pin contacts require a pc board with a minimum thickness of 1.40 mm.

Vertical pin header connectors with compliant pin contacts also require a pc board with a minimum thickness of 1.40 mm.

B. PC Board Circuit Pattern Layout

The pc board layout patterns for the placement of Z-PACK HS3 and HS3 Plus Pin Header and Receptacle Connectors are provided in Figure 6. Component side views shown. When mated, backplane and daughtercard plated through hole columns are aligned.

HS3 Daughtercard

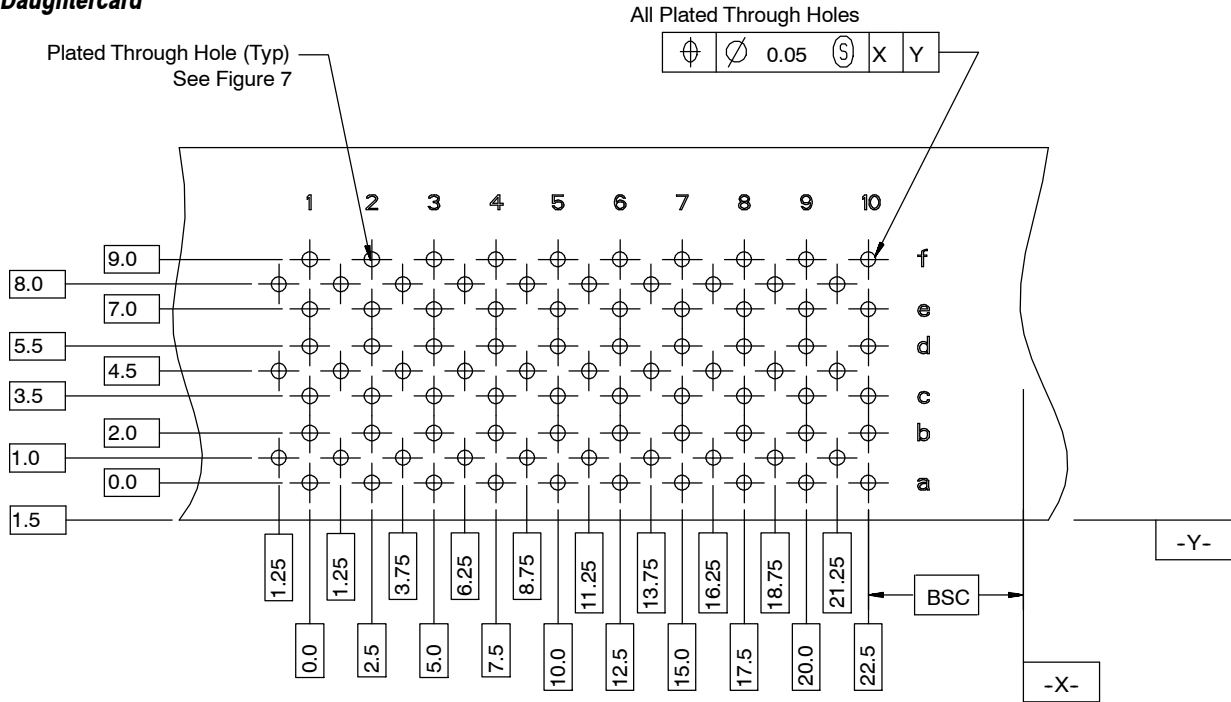

HS3 Plus Daughtercard

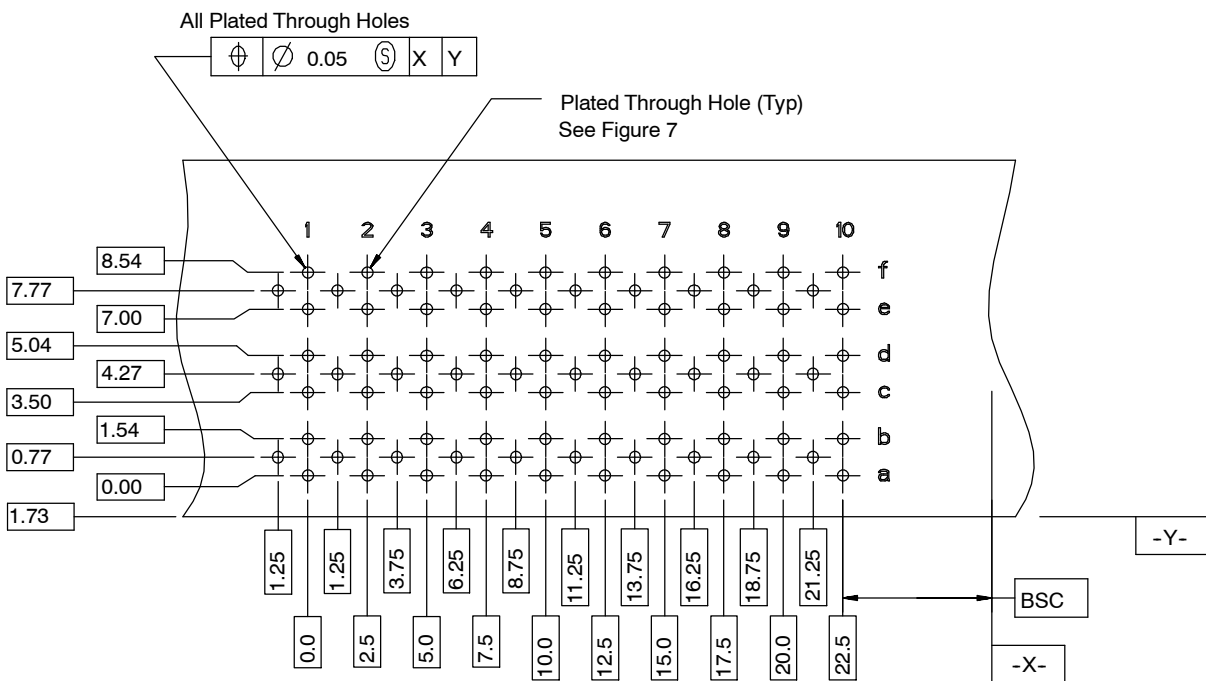
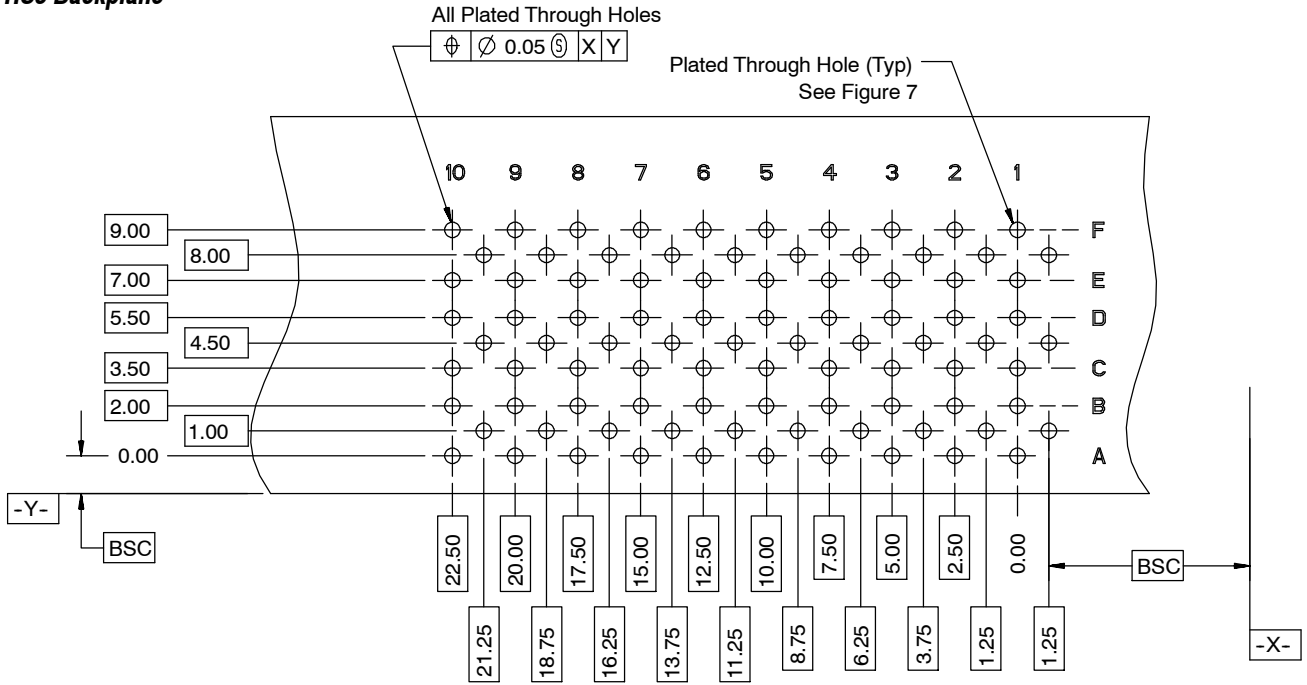

Figure 6 (cont'd)

HS3 Backplane



HS3 Plus Backplane

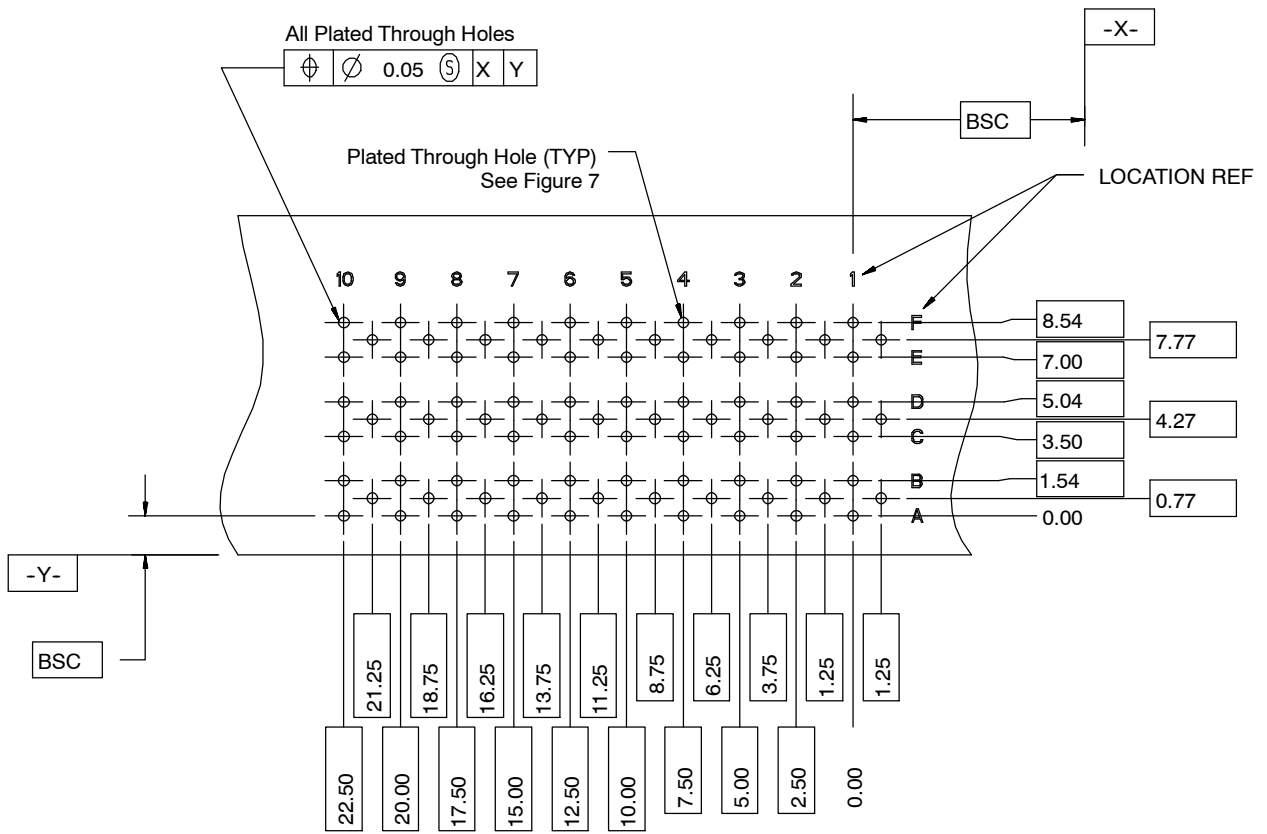
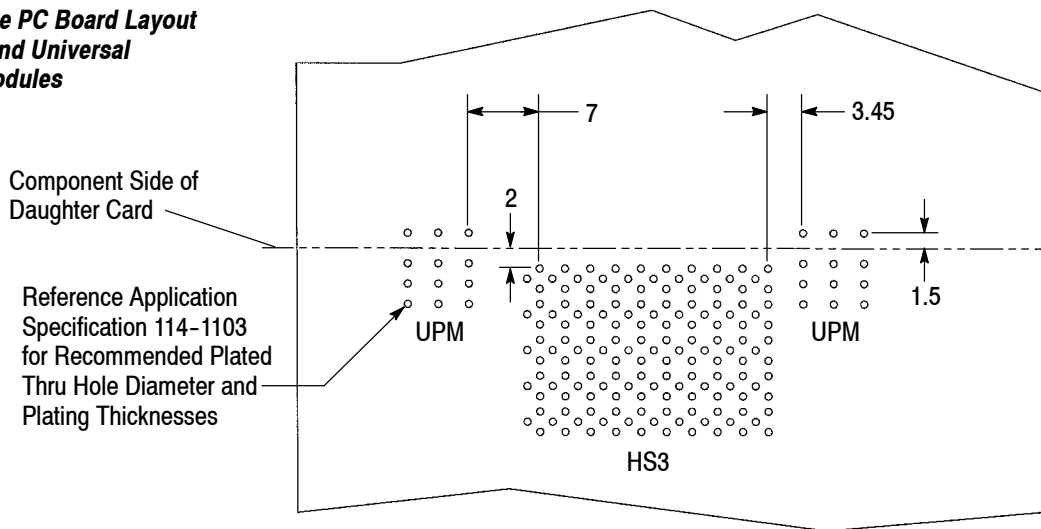

Figure 6 (cont'd)

Backplane PC Board Layout for HS3 and Universal Power Modules



Daughter Card PC Board Layout for HS3 and Universal Power Modules

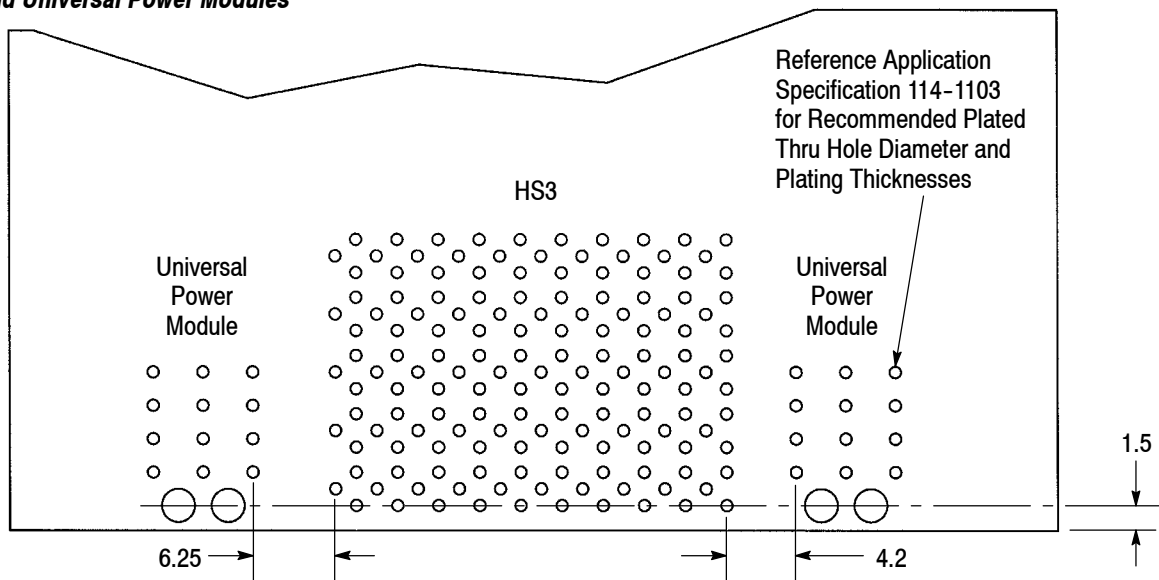

Figure 6 (end)

3.6. Contact Hole Configuration

The contact holes in the pc board for all contacts must be drilled and plated through to specific dimensions shown in Figure 7, Detail A.

3.7. PTH Counterboring

If pc boards are to be back-drilled (counterbored) for signal integrity performance improvement, the depth of the counter bore must be no more than the dimension given in Figure 7, Detail B.

Detail A (HS3 and HS3 Plus)

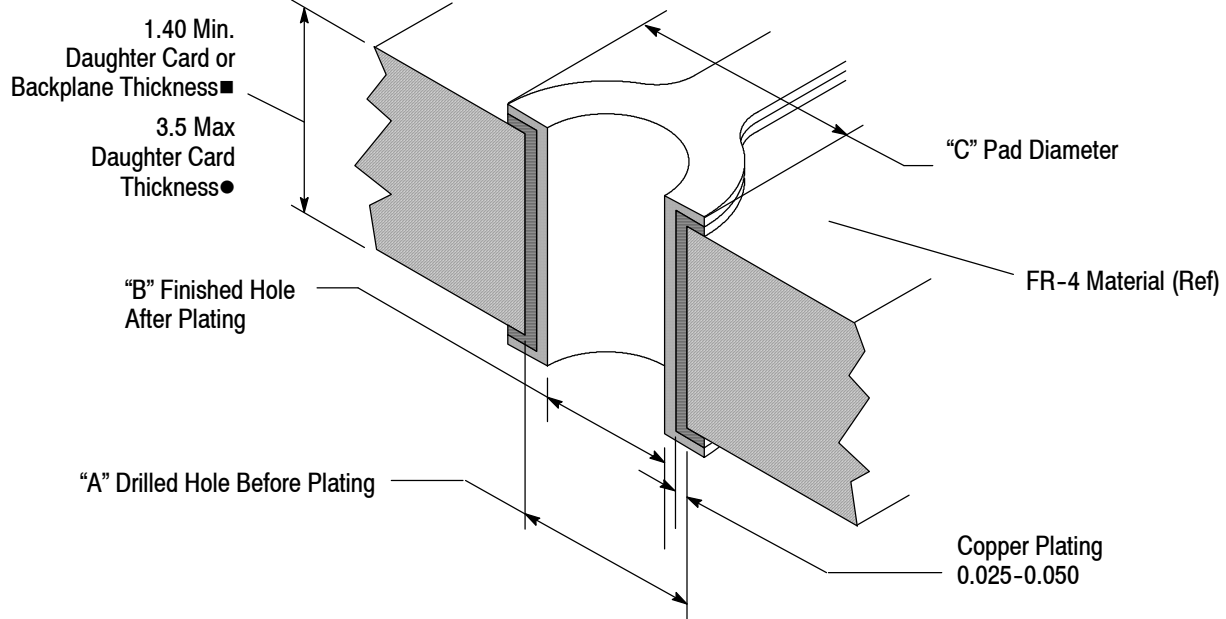

**Detail B (HS3 and HS3 Plus)
Back-Drilled (PTH Counterbore)**

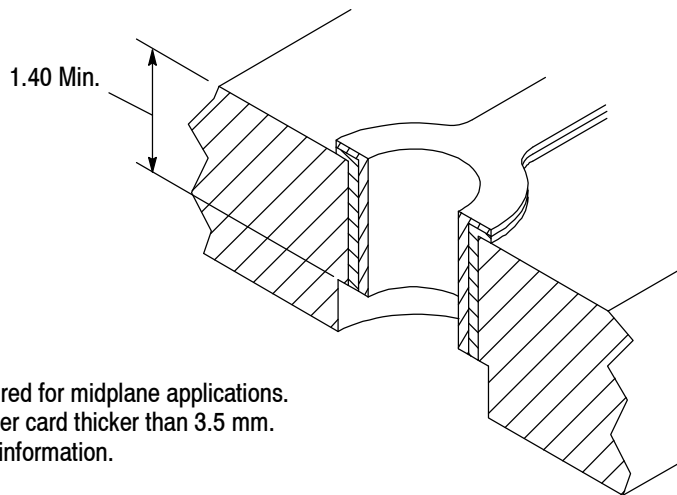

- 3.8 min. backplane thickness required for midplane applications.
 - Special header required for daughter card thicker than 3.5 mm.
- Contact TE Engineering for specific information.

| CONNECTOR | DIMENSION | | | DIMENSION "D" | | |
|-----------|-------------|----------------|------|---|------------------------------------|---------------------------------------|
| | "A" | "B" NOMINAL | "C" | SURFACE FINISH ▲ (HS3 or HS3 Plus) | THICKNESS | |
| | | | | | HS3 | HS3 Plus |
| HS3 | 0.675-0.725 | 0.61• | 1.00 | Hot Air Solder Leveling (HASL) Tin-Lead (Sn Pb) | 0.004-0.010 | 0.0037-0.0123 |
| | | | | Immersion Tin (Sn) | 0.0005-0.0040 | |
| | | | | Organic Solderability Preservative (OSP) | 0.0002-0.0005 | |
| HS3 Plus | 0.53-0.57 | 0.47• | 0.92 | Immersion Gold (Au) Over Nickel (Ni) (ENIG) | 0.004-0.005 Ni 0.0001-0.0005 Au | 0.0001-0.0005 Au 0.00127-0.0076 Ni |
| | | | | Immersion Silver (Ag) | 0.0001-0.0005 | |

▲NOTE: All surfaces finishes may be used on either HS3 or HS3 Plus.

•Tolerance or acceptable range of finished hole diameter is the sum of the plated through hole component tolerances. All component tolerances must be achieved.

Min finished diameter = A(min) - 2 x Copper Thickness(max) - 2 x D(max)

Max finished diameter = A(max) - 2 x Copper Thickness(min) - 2 x D(min)

Figure 7

3.8. Connector Seating

Z-PACK HS3 and HS3 Plus Headers and Receptacles with compliant pin contacts are seated using seating tools 91312-[], 91313-[], 1338743-[], and 1338742-[]. These tools may be used in the application machines listed in Section 5, TOOLING, or with a suitable machine capable of supplying a controllable downward force of 4448 N [1000 lb] *per 100 signal-positions* over the length of the header and 4448 N [1000 lb] *per 100 signal-positions* over the length of the receptacle. Pin headers and receptacles must be seated to the dimension shown in Figure 8.

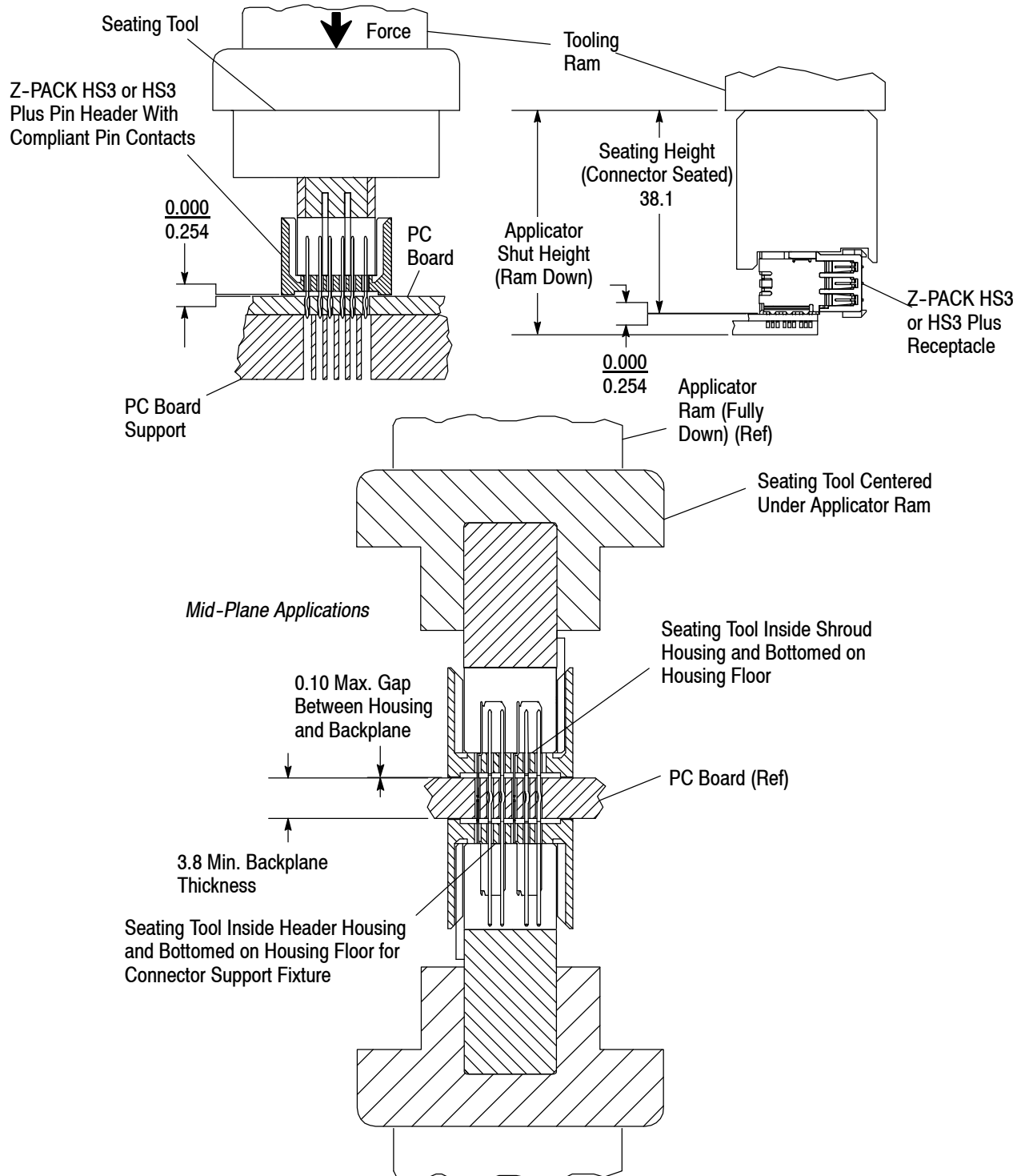

Figure 8

3.9. Solder Process Considerations

Since the Z-PACK HS3 Connector System is a press-in compliant pin type of design, it does not require solder. But, when pc board repair or rework requires soldering after the connectors are already inserted in the pc board, the following applies.



It is imperative that the contact interface be kept clean of flux and cleaning residue, since it acts as an insulator. In addition, flux and cleaning residue that wicks between chicklets and ground planes in the receptacle connector assembly can degrade insulation characteristics of the connector.



Consideration must be given to toxicity and other safety requirements recommended by the solvent manufacturer. Trichloroethylene and Methylene Chloride can be used with no harmful affect to the connectors; however, TE does not recommend them because of the harmful occupational and environmental effects. Both are carcinogenic (cancer-causing) and Trichloroethylene is harmful to the earth's ozone layer.

Air drying of cleaned connectors is recommended. Temperature for the connectors should not exceed -55 to 105°C [-67 to 221°F]. Degradation of the housings could result from extreme temperatures. Gold surfaces of contact tines must be relubricated with a Telcordia approved lubricant if applications require it.

3.10. Connector Installation

A. Initial Positioning

Z-PACK HS3 and HS3 Plus Vertical Pin Headers, and Right-Angle Receptacles must be pre-applied to a pc board by hand.

Connectors should be gripped by the housing only and not by the contacts. When placing a connector into a pc board, all contact tines should be aligned and inserted into the pc board simultaneously to prevent twisting or bending of the contacts.

B. Seating Connectors

Seating force must be applied evenly on the connectors to prevent deformation or other damage to the contacts and housings. When installing header connectors, the insertion force must be simultaneously applied to the shoulders of each contact at the bottom of the slots. When installing right-angle receptacle connectors, the insertion force must be evenly applied to the assembly (top surface of the chicklets) as shown in Figure 8. Refer to Paragraph 3.7 for seating force information. The seating force will vary according to the hole diameter and signal pin count. Approximate force to seat the headers will be 2668-4003 N [600-900 lb] *per 100 signal pins*. Approximate force to seat the receptacles will be 1779-2668 N [400-600 lb] *per 100 signal pins*. Approximate force to seat HS3 Plus headers and receptacles will be 2668-4003 N [600-900 lb] *per 100 signal pins*. Tooling recommendations are covered in Section 5.



*Correct seating of connector is essential to interconnection performance. This includes correct seating height (see Figure 8) and force applied. Overdriving of product will deform parts critical to the quality of the connection. Maximum force occurs prior to seating the connectors on the pc board. For 60-position receptacle modules, the maximum force is 2224 N [500 lb]; for 100-position receptacle modules, the maximum force is 3336 N [750 lb]; and for headers, calculate the maximum force at 62 N [14 lb] *per signal pin*. For 60-position HS3 Plus receptacle modules, the maximum force is 2322 N [522 lb]; for 100-position HS3 Plus receptacle modules: 3870 N [870 lb]; and for HS3 Plus headers calculated the maximum force at 25 N [5.6 lb] *per compliant pin*.*

3.11. Accessories

Guide pins for additional pre-alignment, power pins and receptacles, and special keying inserts are available as shown in Figure 9. Other hardware options to meet specific needs may be available from, or designed by, TE Engineering at customers' request.

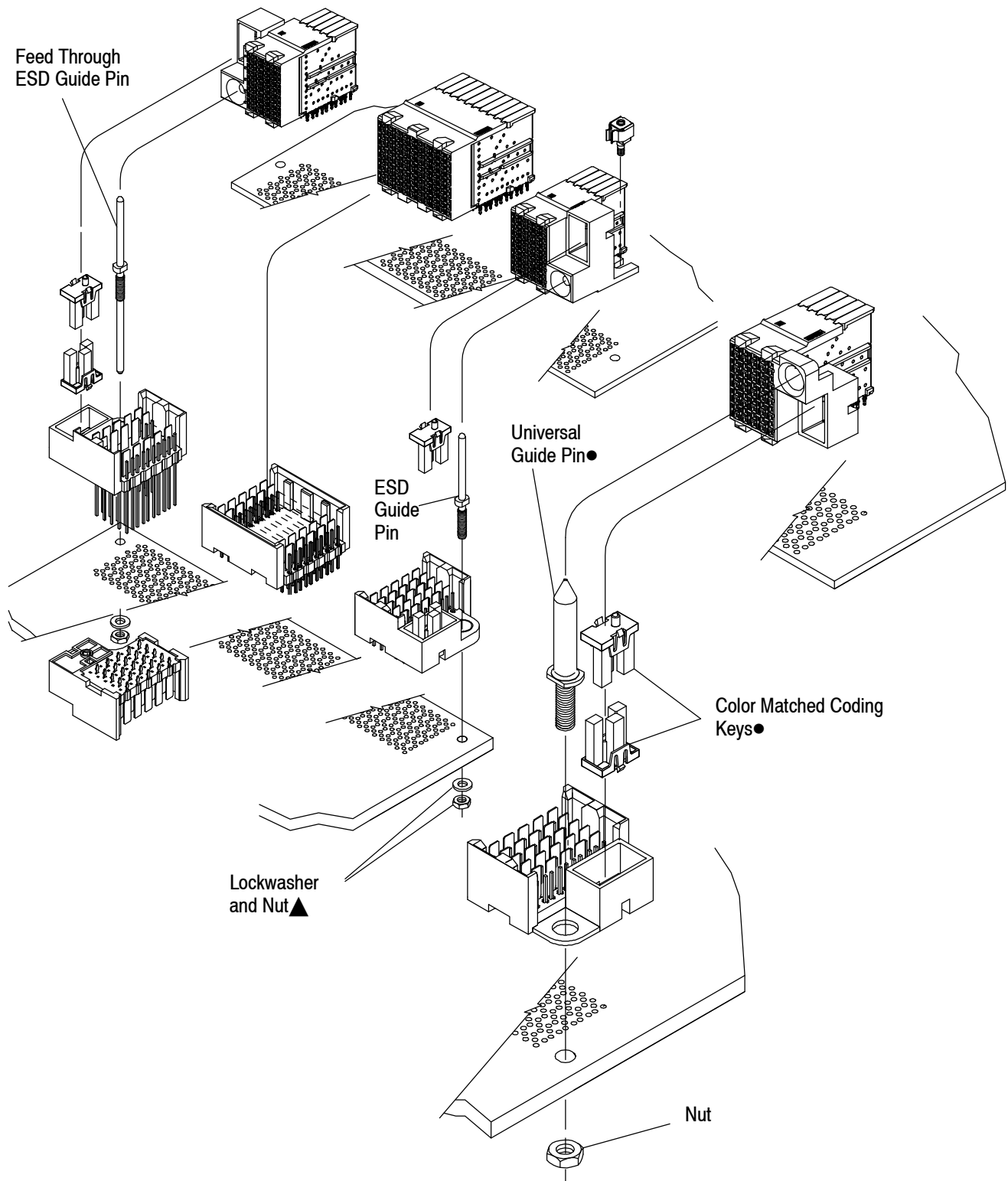

● Coding keys and universal guide pins are not available for 6-row products. ▲ For appropriate nut and lockwasher, refer to the specific customer drawing.

Figure 9

3.12. Repair/Replacement

A. Header Repair

HS3 header assemblies can be repaired without removal from the pc board, in cases where only contacts are in need of replacement. For signal pin contacts, use replacement tool kit 354687-2 (Instruction Sheet 408-9979). For ground blade repair use replacement tool kit 1320534-1 (Instruction Sheet 408-4573). These kits contain tips for removal and replacement of compliant pin contacts. HS3 Plus Header assemblies do not allow for individual signal contact replacement. Damaged headers generally must be completely replaced.

B. Receptacle Repair

Receptacle construction does not allow for replacement of individual contacts or shields. Damaged integral receptacles generally must be completely replaced. Receptacles can be repaired by removing and replacing only the damaged connector module, as follows:

1. To remove the receptacle housing from the connector assembly, use receptacle housing removal tool 1338744-1 (Instruction Sheet 408-8393).
2. Use chicklet removal tool 1338745-1 (6-row), or 1338746-1 (10-row) to remove the chicklet sub-assemblies. Refer to Instruction Sheet 408-8410.
3. Refer to Instruction Sheet 408-8394 to seat the new module in the proper position.

4. QUALIFICATIONS

The Z-PACK HS3 Connector System is Recognized by Underwriters Laboratories Inc. (UL) and Certified to CSA International by UL in File Number E28476.

5. TOOLING

Figure 10 provides tool part numbers and instructional material related to Z-PACK HS3 and HS3 Plus Connector Systems.

NOTE

TE Tool Engineers have designed machines for a variety of application requirements. For assistance in setting up prototype and production line equipment, contact TE Tool Engineering through your local TE Representative or call the Tooling Assistance Center number at the bottom of page 1.

- **PC Board Support**

A pc board support must be used to prevent bowing of the pc board during the insertion of a connector into the board. It should have flat surfaces with holes or a channel wide and deep enough to receive the contact compliant pins and other attaching hardware during installation of the connector on the pc board.

- **Seating Tools**

Seating tools have been designed to push on the contact and seat the connector on the pc board. The tool will prevent contacts from backing out of the housing and prevent damage to the housing. The seating tools may be used with the power units listed or arbor frame assembly.

- **Impact Repair Tools**

Impact repair tools are designed to remove damaged contacts from housings without damaging the housing. The tools must be used with a support that is deep enough to allow full extraction of the contact.

- **Power Units**

Power units are automatic or semi-automatic machines used to assist in the application of a product. A power unit supplies the force to seat the connector onto the pc board using seating tools.

- **Arbor Frame Assembly**

Manual arbor frame assemblies are used to exert a downward force used to apply connectors to a pc board using seating tools.

- **Extraction Tools**

Extraction Tools are designed to remove contacts or housings without damaging any parts of the connector.

- **Insertion Tools**

Insertion Tools are designed for inserting individual contacts or connector assemblies into areas without damaging or touching other component parts.

| PRODUCT | | | TOOLING | |
|-----------|--------|---|-------------------------|---|
| CONNECTOR | TYPE | DESCRIPTION | PART NUMBER (DOCUMENT) | DESCRIPTION |
| 6-ROW | HEADER | 30-POSITION-RIGHT 30-POSITION-LEFT 30-POSITION-THRU 60-POSITION-THRU | 91313-1 (408-4546) | 30-POSITION HEADER SEATING TOOL |
| | | | 91313-2 (408-4546) | 60-POSITION HEADER SEATING TOOL |
| | RECEPT | 30-POSITION-RIGHT 30-POSITION-LEFT 30-POSITION-THRU 60-POSITION-THRU | 1338742-1 (408-8394) | 60-POSITION RECEPTACLE SEATING TOOL |
| | | | 1338742-2 (408-8394) | 120-POSITION RECEPTACLE SEATING TOOL |
| | --- | --- | 354687-2 (408-9979) | SIGNAL PIN REPAIR KIT |
| | | | 1320534-1 (408-4573) | GROUND BLADE REPAIR KIT |
| | | | 1338744-1 (408-8393) | RECEPTACLE HOUSING REMOVAL TOOL |
| | | | 1338745-1 (408-8410) | CHICKLET REMOVAL TOOL |
| 10-ROW | HEADER | 50-POSITION-RIGHT 50-POSITION-LEFT 100-POSITION-THRU | 91312-1 (408-4546) | 50-POSITION HEADER SEATING TOOL |
| | | | 91312-2 (408-4546) | 100-POSITION HEADER SEATING TOOL |
| | RECEPT | 50-POSITION-RIGHT 50-POSITION-LEFT 100-POSITION-THRU | 1338743-1 (408-8394) | 100-POSITION RECEPTACLE SEATING TOOL |
| | | | 1338743-2 (408-8394) | 200-POSITION RECEPTACLE SEATING TOOL |
| | --- | --- | 354687-2 (408-9979) | SIGNAL PIN REPAIR KIT |
| | | | 1320534-2 (408-4573) | GROUND BLADE REPAIR KIT |
| | | | 1338744-1 (408-8393) | RECEPTACLE HOUSING REMOVAL TOOL |
| | | | 1338746-1 (408-8410) | CHICKLET REMOVAL TOOL |

Figure 10 (cont'd)

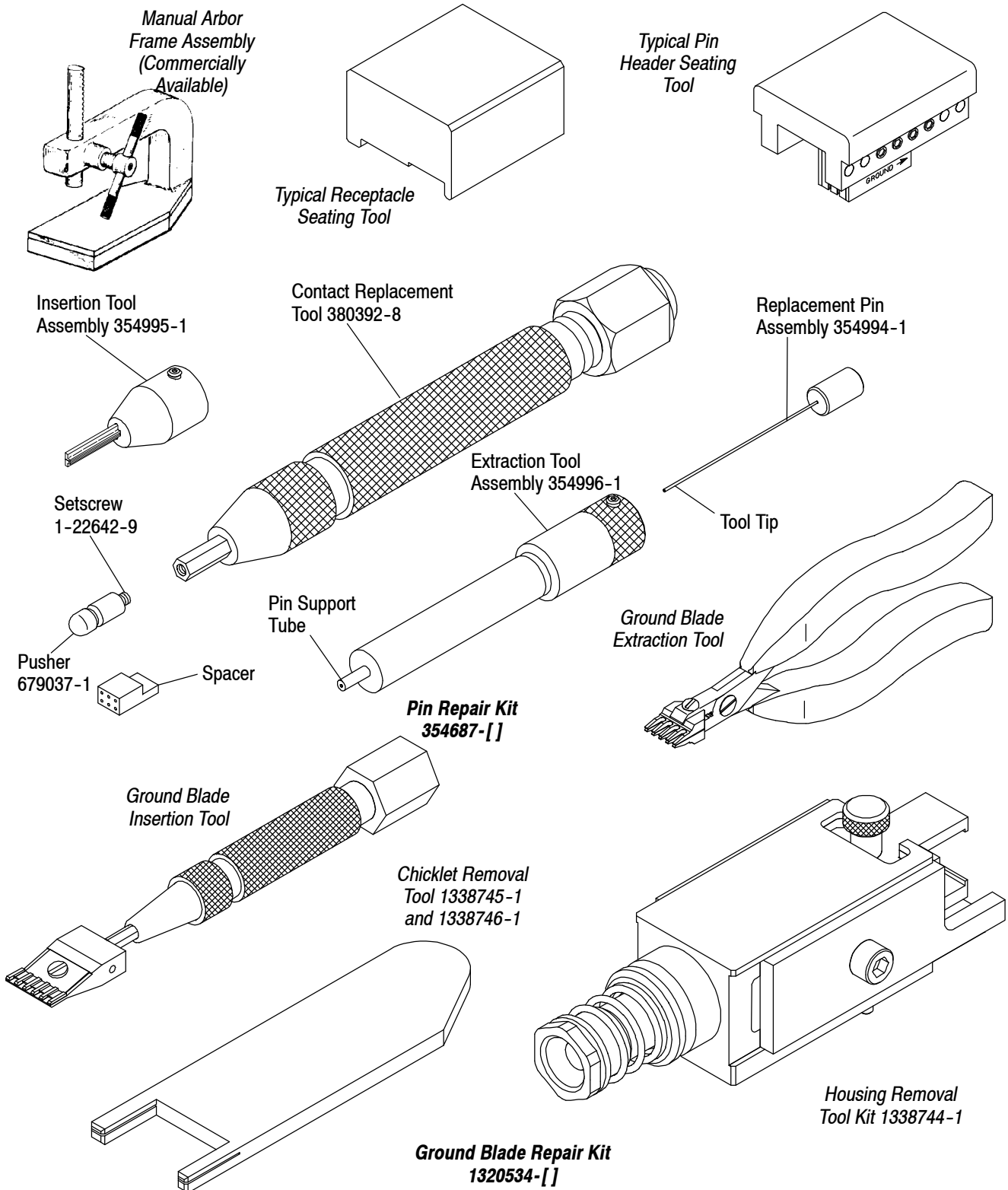

NOTE: Other power units that use seating tools for this product line may be available through TE. Machines that may accommodate your production needs are bench machines BMEP-3T and BMEP-5T; stand alone machines MEP-6T and MEP-12T; and a fully automated machine available, AEP-12T. Contact the Tooling Assistance Center (TAC) phone number at the bottom of page 1 for information on these Automation Services Group (ASG) machines.

Figure 10 (end)

6. VISUAL AID

Figure 11 shows a typical application of an Z-PACK HS3 Connector System. This illustration should be used by production personnel to ensure a correctly applied product. Applications which DO NOT appear correct should be inspected using the information in the preceding pages of this specification and in the instructional material shipped with the product.

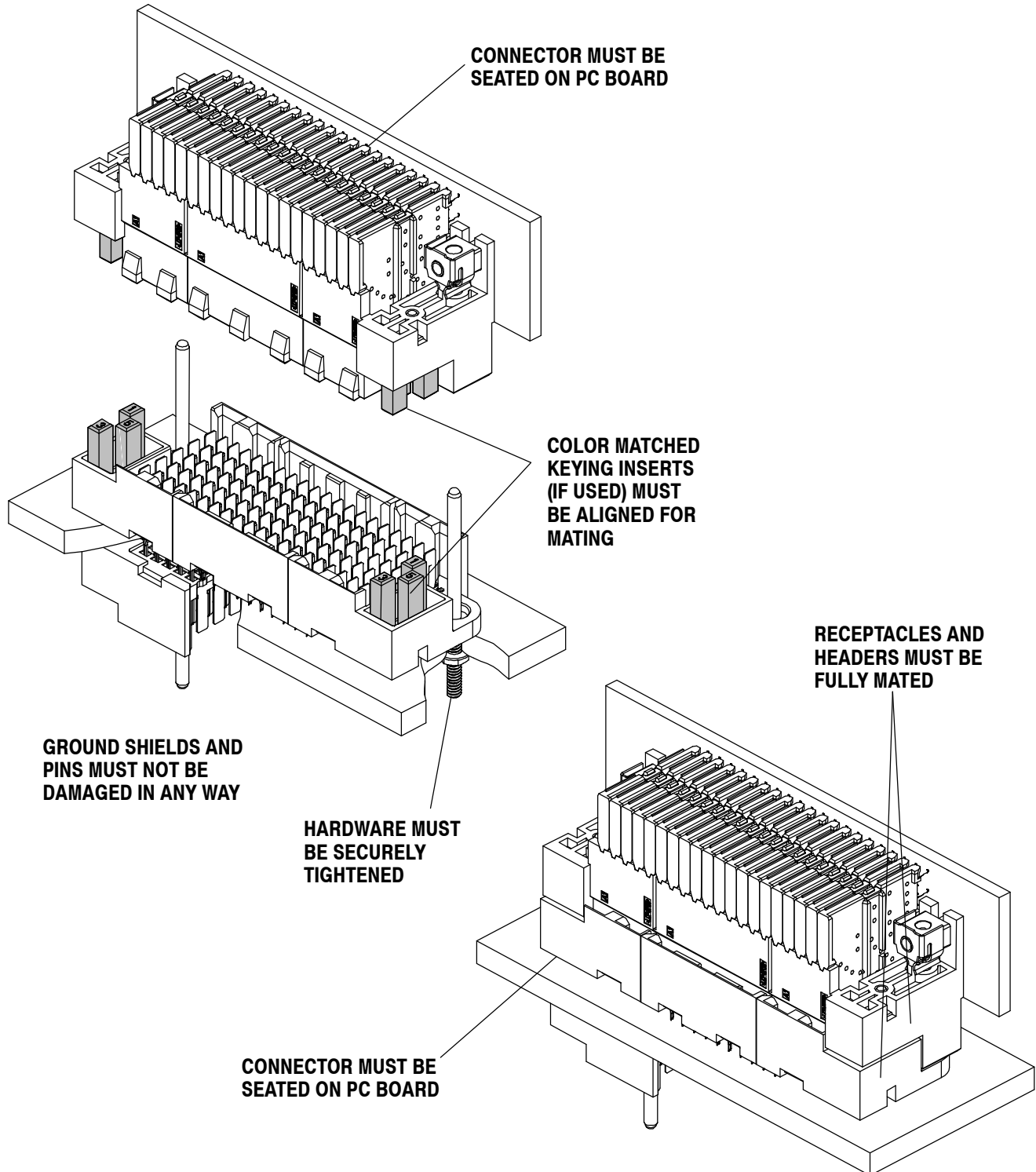

FIGURE 11. VISUAL AID