

- ① HOUSING: HIGH TEMPERATURE THERMOPLASTIC. COLOR - NATURAL
- ② CONTACT: PHOSPHOR BRONZE.
- ③ CONTACT FINISH: .001269[.000050] MIN NICKEL ALL OVER. GOLD FLASH OVER NICKEL IN CONTACT AREA. .002537[.000100] MIN TIN OVER NICKEL ON SOLDER TAILS.
- ④ CONTACT FINISH: .001269[.000050] MIN NICKEL ALL OVER. .000375[.000015] MIN GOLD OVER NICKEL IN CONTACT AREA. .002537[.000100] MIN TIN OVER NICKEL ON SOLDER TAILS.
- ⑤ CONTACT FINISH: .001269[.000050] MIN NICKEL ALL OVER. .000757[.000030] MIN GOLD OVER NICKEL IN CONTACT AREA. .002537[.000100] MIN TIN OVER NICKEL ON SOLDER TAILS.
- ⑥ DISTANCE FROM CONTACT POINT TO BOTTOM OF CARD SLOT.
- ⑦ AMP PART NUMBER, DATE CODE AND CSA LOGO SHOULD BE MARKED ON THE SIDE OF THE HOUSING NEAR THE AMP LOGO.
- ⑧ CORED OR SOLID SIDE WALLS ARE AT DISCRETION OF AMP INCORPORATED.

SEE SHEET 2 FOR HOLE PATTERN

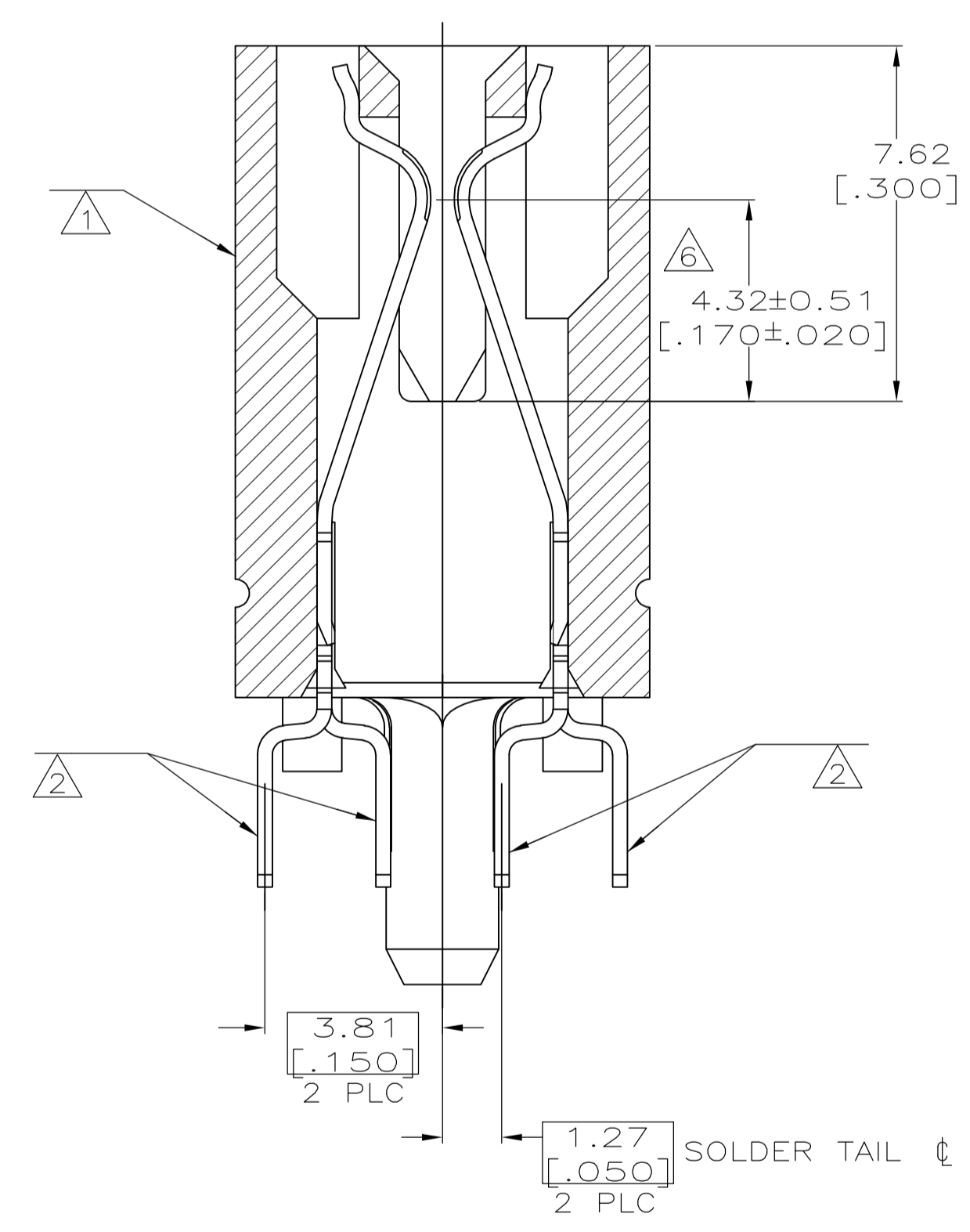
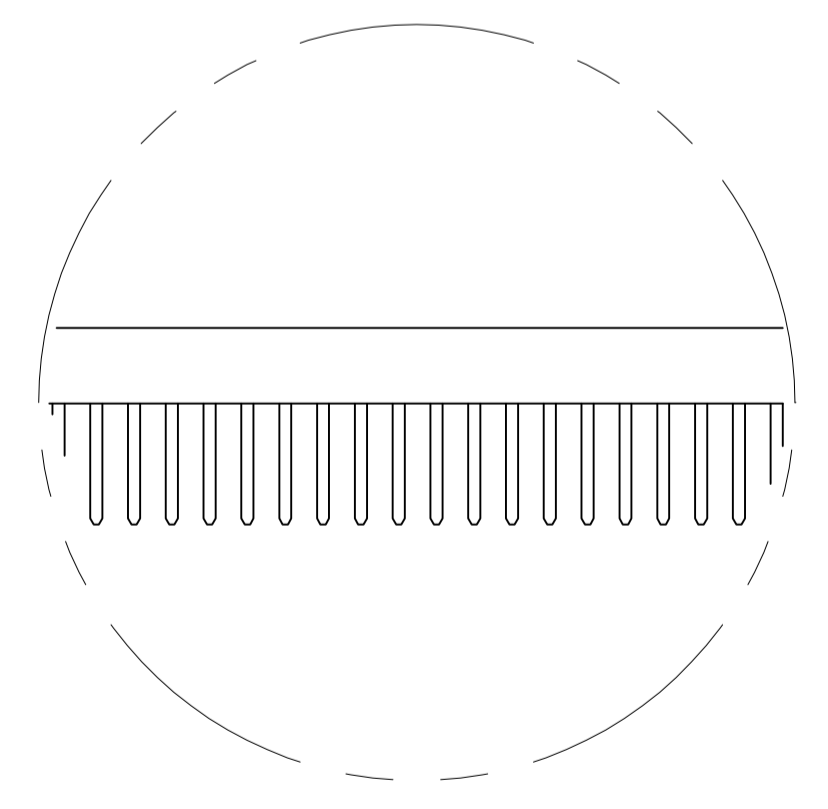

3.56 [.140]	⑤	1-5145154-2
3.18 [.125]	⑤	5145154-8
2.54 [.100]	⑤	5145154-4
2.54 [.100]	④	5145154-2
2.54 [.100]	③	5145154-1

OBSOLETE

W	FINISH	PART NUMBER
---	--------	-------------

THIS DRAWING IS A CONTROLLED DOCUMENT.

DIMENSIONS: mm [INCHES]	TOLERANCES UNLESS OTHERWISE SPECIFIED:	DRN AL FRANTUM 20 MAY 04	CHK AL FRANTUM 20 MAY 04	APVD -	NAME
0 PLC ± -	1 PLC ± -	2 PLC ± .25[.01]	3 PLC ± .125[.005]	4 PLC ± -	ANGLES ± -
MATERIAL	FINISH	PRODUCT SPEC 108-14034	APPLICATION SPEC 114-26012	SIZE	CAGE CODE DRAWING NO
		RESTRICTED TO	WEIGHT	A1 00779	5145154
		CUSTOMER DRAWING	SCALE 4:1	SHEET 1 OF 2	REV B

Tyco Electronics Corporation
 Harrisburg, Pa 17105-3608

CONNECTOR ASSEMBLY,
 60 DUAL POSITION,
 1.27 [.050] SERIES, CARD EDGE

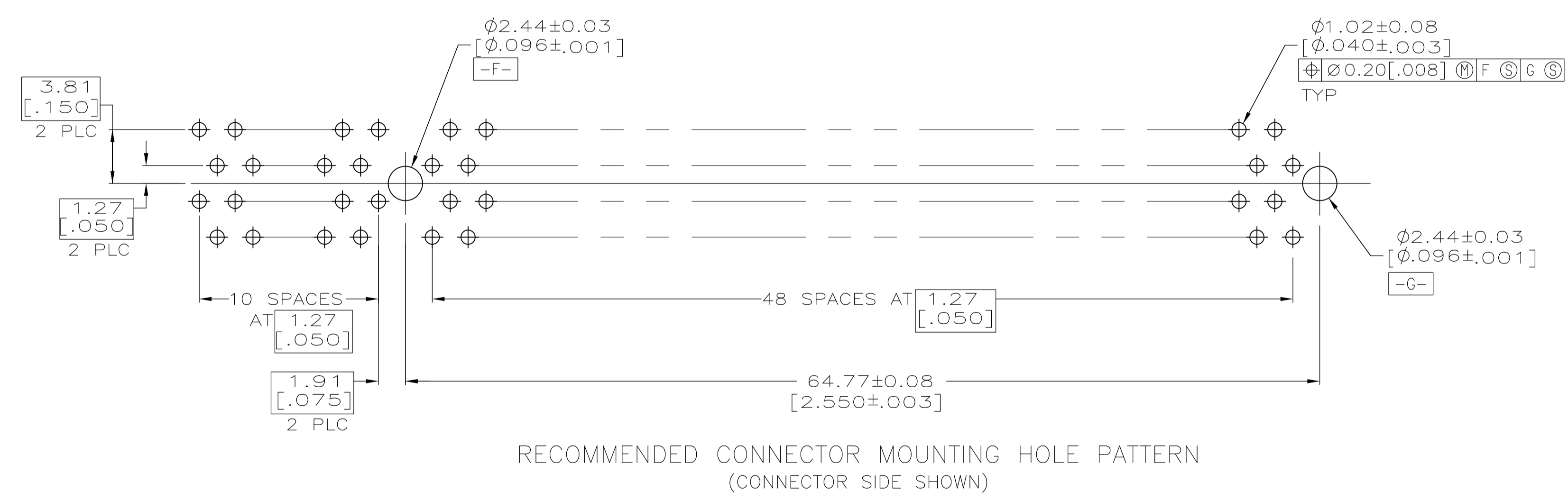
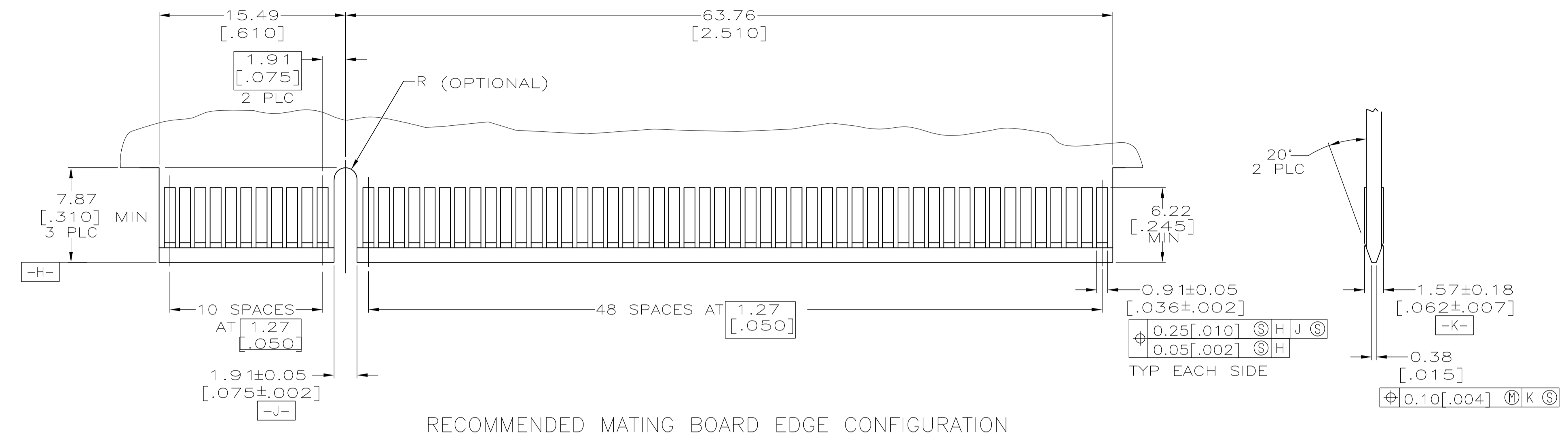

THIS DRAWING IS A CONTROLLED DOCUMENT.		DN AL FRANTUM 20 MAY 04	Tyco Electronics Tyco Electronics Corporation Harrisburg, Pa 17105-3608	
DIMENSIONS: mm [INCHES]		CHK AL FRANTUM 20 MAY 04	NAME	
TOLERANCES UNLESS OTHERWISE SPECIFIED:		APVD	PRODUCT SPEC	
0 PLC ± -	1 PLC ± -	108-14034		
2 PLC ± .25 [.01]	3 PLC ± .125 [.005]	APPLICATION SPEC		
4 PLC ± - ± .2	ANGLES ± - ± .2	SIZE	CAGE CODE	DRAWING NO
MATERIAL	FINISH	114-26012	A1	00779
WEIGHT		C=5145154		RESTRICTED TO
CUSTOMER DRAWING		SCALE 4:1	SHEET 2 OF 2	REV B