

5-146257-4 Product Details

[Share](#) [Print](#) [Email](#)



5-146257-4

TE Internal Number: 5-146257-4

 Active

[View 3D PDF](#)

.100 inch AMPMODU Headers

 Always EU RoHS/ELV Compliant
(Statement of Compliance)

Product Highlights:

- Connector
- Header Type = Breakaway
- 8 Positions
- Mating Post Length = 5.84 mm
- Row-to-Row Spacing = 2.54 mm

[View all Features](#)

Quick Links

- ▶ [Pricing & Availability](#)
- ▶ [Search for Tooling](#)
- ▶ [Product Feature Selector](#)
- ▶ [Contact Us About This Product](#)

[Add to My Part List](#)

[Request Sample](#)

[Find Similar Products](#)

[Buy Product](#)

Documentation & Additional Information

Product Drawings:

- [HEADER ASSEMBLY, MOD II, BREAKAWAY, DOUBLE ROW, HI...](#) (PDF, English)

Catalog Pages/Data Sheets:

- None Available

Product Specifications:

- None Available

Application Specifications:

- None Available

Instruction Sheets:

- None Available

CAD Files: (CAD Format & Compression Information)

- [2D Drawing](#) (DXF, Version M)
- [3D Model](#) (IGES, Version M)
- [3D Model](#) (STEP, Version M)

[List all Documents](#)

Additional Information:

- [Product Line Information](#)

Related Products:

- [Tooling](#)

Product Features (Please use the Product Drawing for all design activity)

Product Type Features:

- Product Type = Connector
- Mount Angle = Vertical
- PCB Mount Retention = Without
- Board Standoff = With
- Mating Connector Lock = Without
- Post Size (mm [in]) = 0.64 [.025]

Mechanical Attachment:

- Mounting Ears = Without
- Panel Mount Retention = Without

Electrical Characteristics:

- Current Rating (A) = 3
- Insulation Resistance (MΩ) = 5,000
- Dielectric Withstanding Voltage (V) = 750

Termination Features:

Housing Features:

- Housing Material = Thermoplastic - GF
- UL Flammability Rating = UL 94V-0

Configuration Features:

- Number of Positions = 8
- Number of Rows = 2
- Surface Mount Compatible = Yes

Industry Standards:

- RoHS/ELV Compliance = RoHS compliant, ELV compliant
- Lead Free Solder Processes = Wave solder capable to 260°C, Wave solder capable to 240°C, Wave solder capable to 265°C, Reflow solder capable to 245°C, Reflow solder capable to 260°C, Pin-in-Paste capable to 245°C, Pin-in-Paste capable to 260°C
- RoHS/ELV Compliance History = Always was RoHS

- Termination Post Length (mm [in]) = 3.05 [0.120]

Dimensions:

- Mating Post Length (mm [in]) = 5.84 [0.230]

Body Features:

- Header Type = Breakaway
- Row-to-Row Spacing (mm [in]) = 2.54 [0.100]
- Selectively Loaded = No
- Mount Type = Printed Circuit Board

Contact Features:

- Contact Plating, Mating Area, Material = Gold (30)
- Solder Tail Contact Plating = Matte Tin over Nickel, Tin over Nickel
- Contact Shape = Square
- Contact Base Material = Phosphor Bronze

compliant

- Approved Standards = CSA LR7189, UL E28476

Environmental:

- Operating Temperature (°C) = -65 - +105

Conditions for Usage:

- High Temperature Housing = Yes

Operation/Application:

- High Speed Serial Data Connector = No

Other:

- Brand = AMP

Corporate Information

[About TE](#)
[Investors](#)
[News Room](#)
[Supplier Portal](#)
[Careers](#)
[Terms & Conditions](#)
[Privacy Policy](#)

Quick Links

[Distributor Inventory](#)
[Product Cross Reference](#)
[Documents & Drawings](#)
[Product Compliance Support Center](#)
[Site Map](#)

Customer Support

[Email or Chat With Us](#)
[Find a Phone Number](#)
[Knowledge Base](#)
[Manage Your Account](#)

Keep Me Informed

- ASSEMBLY MAY BE BROKEN TO THE DESIRED NUMBER OF POSITIONS
- TRUE POSITION TOLERANCE OF THE POST TIPS APPLIES WHEN THE HEADER IS HELD FLAT AGAINST THE PRINTED CIRCUIT BOARD
- THE NOTED DIMENSIONS APPLY AT THE INTERSECTION OF THE POST AND HOUSING
- POST PLATING: 0.00762[.000030] GOLD ON CONTACT AREA, 0.00254-0.00508[.000100-.000200] MATTE TIN-LEAD ON SOLDERTAIL, ALL OVER 0.00127[.000050] NICKEL.
- HOUSING: LCP, COLOR-BLACK.
- POST: PHOSPHOR BRONZE
- PARTS PACKAGED IN TUBES.
- POST PLATING: 0.00762[.000030] GOLD ON CONTACT AREA, 0.00254-0.00508[.000100-.000200] MATTE TIN ON SOLDERTAIL, ALL OVER 0.00127[.000050] NICKEL.
- PRELIMINARY PART - NOT RELEASED FOR PRODUCTION.
- OBSOLETE PARTS: OBSOLETE CIS STREAMLINING PER D.RENAUD/D.SINISI

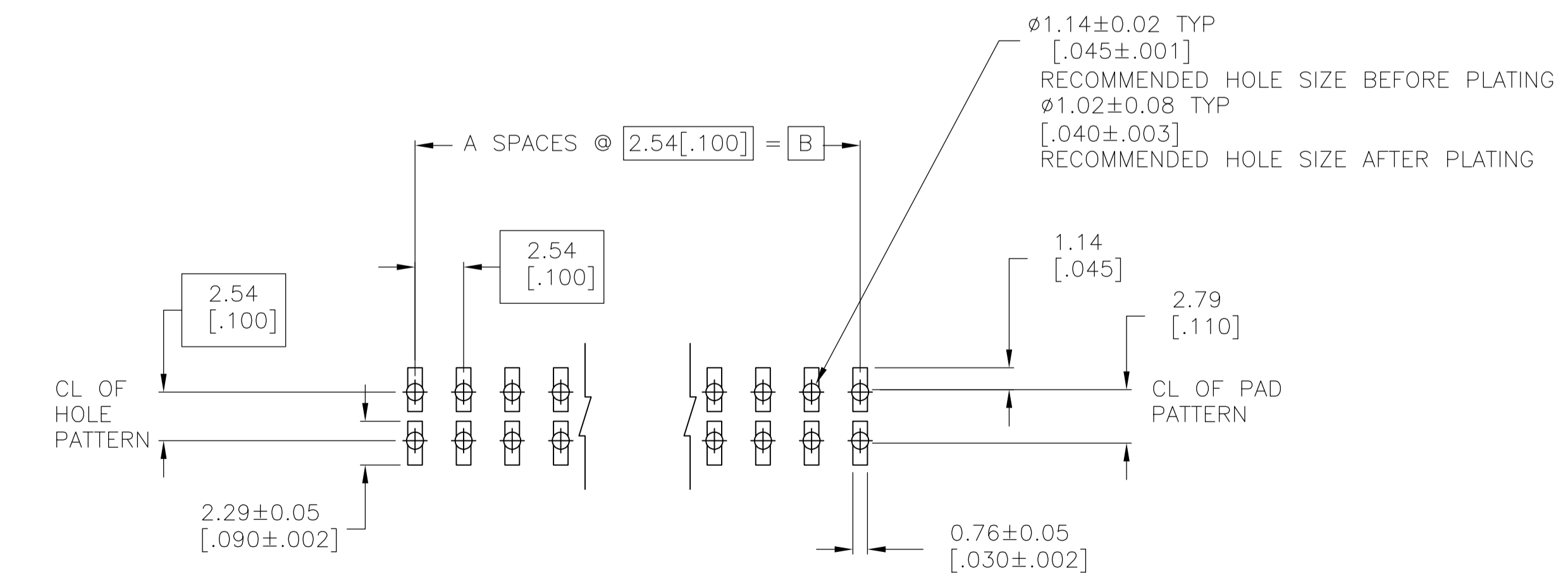
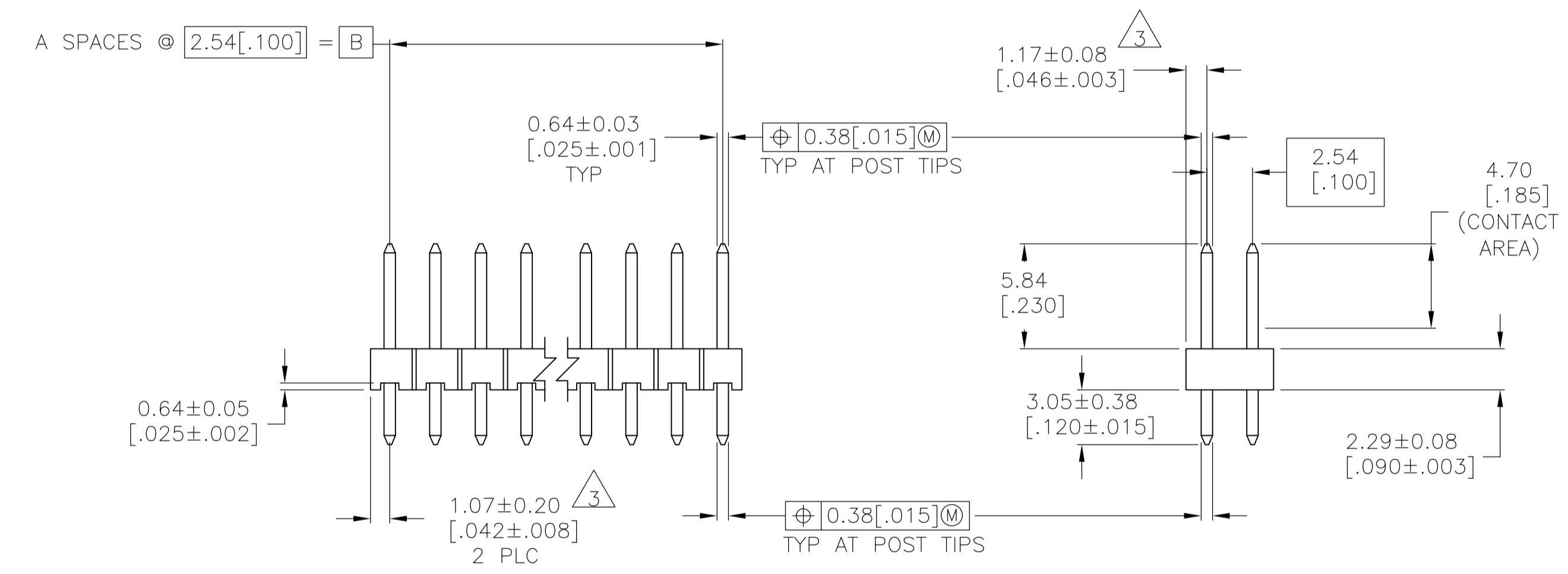
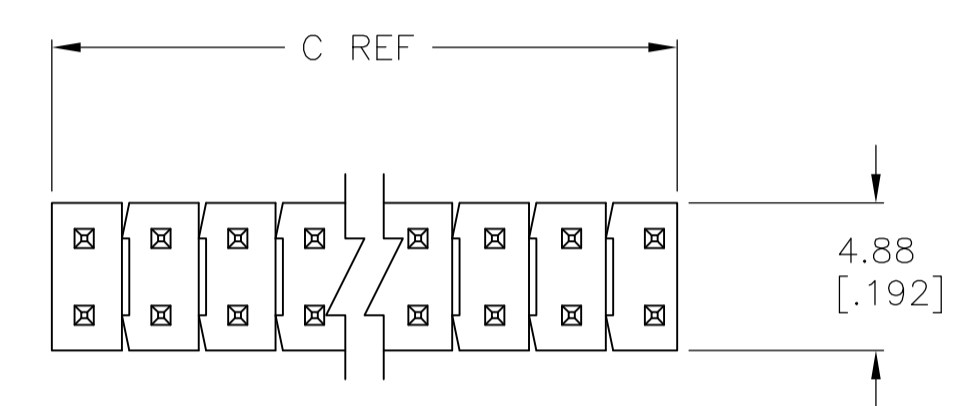

RECOMMENDED PC BOARD MOUNTING DIMENSIONS FOR .063 [1.60] THICK PC BOARD AND .012 [.305] STENCIL THICK.

8	101.19 [3.984]	99.06 [3.900]	39	80	9-146257-0
8	98.65 [3.884]	96.52 [3.800]	38	78	8-146257-9
8	96.11 [3.784]	93.98 [3.700]	37	76	8-146257-8
8	93.57 [3.684]	91.44 [3.600]	36	74	8-146257-7
8	91.03 [3.584]	88.90 [3.500]	35	72	8-146257-6
8	88.49 [3.484]	86.36 [3.400]	34	70	8-146257-5
8	85.95 [3.384]	83.82 [3.300]	33	68	8-146257-4
8	83.41 [3.284]	81.28 [3.200]	32	66	8-146257-3
8	80.87 [3.184]	78.74 [3.100]	31	64	8-146257-2
8	78.33 [3.084]	76.20 [3.000]	30	62	8-146257-1
8	75.79 [2.984]	73.66 [2.900]	29	60	8-146257-0
8	73.25 [2.884]	71.12 [2.800]	28	58	7-146257-9
8	70.71 [2.784]	68.58 [2.700]	27	56	7-146257-8
8	68.17 [2.684]	66.04 [2.600]	26	54	7-146257-7
8	65.63 [2.584]	63.5 [2.500]	25	52	7-146257-6
8	63.09 [2.484]	60.96 [2.400]	24	50	7-146257-5
8	60.55 [2.384]	58.42 [2.300]	23	48	7-146257-4
8	58.01 [2.284]	55.88 [2.200]	22	46	7-146257-3
8	55.47 [2.184]	53.34 [2.100]	21	44	7-146257-2
8	52.93 [2.084]	50.80 [2.000]	20	42	7-146257-1
8	50.39 [1.984]	48.26 [1.900]	19	40	7-146257-0
8	47.85 [1.884]	45.72 [1.800]	18	38	6-146257-9
8	45.31 [1.784]	43.18 [1.700]	17	36	6-146257-8
8	42.77 [1.684]	40.64 [1.600]	16	34	6-146257-7
8	40.23 [1.584]	38.10 [1.500]	15	32	6-146257-6
8	37.69 [1.484]	35.56 [1.400]	14	30	6-146257-5
8	35.15 [1.384]	33.02 [1.300]	13	28	6-146257-4
8	32.61 [1.284]	30.48 [1.200]	12	26	6-146257-3
8	30.07 [1.184]	27.94 [1.100]	11	24	6-146257-2
8	27.53 [1.084]	25.40 [1.000]	10	22	6-146257-1
8	24.99 [.984]	22.86 [.900]	9	20	6-146257-0
8	22.45 [.884]	20.32 [.800]	8	18	5-146257-9
8	19.91 [.784]	17.78 [.700]	7	16	5-146257-8
8	17.37 [.684]	15.24 [.600]	6	14	5-146257-7
8	14.83 [.584]	12.70 [.500]	5	12	5-146257-6
8	12.29 [.484]	10.16 [.400]	4	10	5-146257-5
8	9.75 [.384]	7.62 [.300]	3	8	5-146257-4
8	7.21 [.284]	5.08 [.200]	2	6	5-146257-3
8	4.67 [.184]	2.54 [.100]	1	4	5-146257-2
8	-	-	0	2	5-146257-1
PLATING	C	B	A	NO. OF POSITIONS	PART NUMBER

9	17.37 [.684]	15.24 [.600]	6	14	4-146257-6
9	9.75 [.384]	7.62 [.300]	3	8	4-146257-5
9	7.21 [.284]	5.08 [.200]	2	6	4-146257-4
9	24.99 [.984]	22.86 [.900]	9	20	4-146257-3
9	75.79 [2.984]	73.66 [2.900]	29	60	4-146257-2
9	17.37 [.684]	15.24 [.600]	6	14	4-146257-1
9	101.19 [3.984]	99.06 [3.900]	39	80	4-146257-0
9	98.65 [3.884]	96.52 [3.800]	38	78	3-146257-9
9	96.11 [3.784]	93.98 [3.700]	37	76	3-146257-8
9	93.57 [3.684]	91.44 [3.600]	36	74	3-146257-7
9	91.03 [3.584]	88.90 [3.500]	35	72	3-146257-6
9	88.49 [3.484]	86.36 [3.400]	34	70	3-146257-5
9	85.95 [3.384]	83.82 [3.300]	33	68	3-146257-4
9	83.41 [3.284]	81.28 [3.200]	32	66	3-146257-3
9	80.87 [3.184]	78.74 [3.100]	31	64	3-146257-2
9	78.33 [3.084]	76.20 [3.000]	30	62	3-146257-1
9	75.79 [2.984]	73.66 [2.900]	29	60	3-146257-0
9	73.25 [2.884]	71.12 [2.800]	28	58	2-146257-9
9	70.71 [2.784]	68.58 [2.700]	27	56	2-146257-8
9	68.17 [2.684]	66.04 [2.600]	26	54	2-146257-7
9	65.63 [2.584]	63.5 [2.500]	25	52	2-146257-6
9	63.09 [2.484]	60.96 [2.400]	24	50	2-146257-5
9	60.55 [2.384]	58.42 [2.300]	23	48	2-146257-4
9	58.01 [2.284]	55.88 [2.200]	22	46	2-146257-3
9	55.47 [2.184]	53.34 [2.100]	21	44	2-146257-2
9	52.93 [2.084]	50.80 [2.000]	20	42	2-146257-1
9	50.39 [1.984]	48.26 [1.900]	19	40	2-146257-0
9	47.85 [1.884]	45.72 [1.800]	18	38	1-146257-9
9	45.31 [1.784]	43.18 [1.700]	17	36	1-146257-8
9	42.77 [1.684]	40.64 [1.600]	16	34	1-146257-7
9	40.23 [1.584]	38.10 [1.500]	15	32	1-146257-6
9	37.69 [1.484]	35.56 [1.400]	14	30	1-146257-5
9	35.15 [1.384]	33.02 [1.300]	13	28	1-146257-4
9	32.61 [1.284]	30.48 [1.200]	12	26	1-146257-3
9	30.07 [1.184]	27.94 [1.100]	11	24	1-146257-2
9	27.53 [1.084]	25.40 [1.000]	10	22	1-146257-1
9	24.99 [.984]	22.86 [.900]	9	20	1-146257-0
9	22.45 [.884]	20.32 [.800]	8	18	1-146257-9
9	19.91 [.784]	17.78 [.700]	7	16	1-146257-8
9	17.37 [.684]	15.24 [.600]	6	14	1-146257-7
9	14.83 [.584]	12.70 [.500]	5	12	1-146257-6
9	12.29 [.484]	10.16 [.400]	4	10	1-146257-5
9	9.75 [.384]	7.62 [.300]	3	8	1-146257-4
9	7.21 [.284]	5.08 [.200]	2	6	1-146257-3
9	4.67 [.184]	2.54 [.100]	1	4	1-146257-2
9	-	-	0	2	1-146257-1
PLATING	C	B	A	NO. OF POSITIONS	PART NUMBER

THIS DRAWING IS A CONTROLLED DOCUMENT.

DIMENSIONS: mm	TOLERANCES UNLESS OTHERWISE SPECIFIED:	DIN R BROWN 19JAN05	APVO J. GESFORD 19JAN05	NAME
0 PLC ± -	1 PLC ± 0.15[.02]	19JAN05	PRODUCT SPEC	TE Connectivity
2 PLC ± 0.12[.005]	3 PLC ± 0.12[.005]	19JAN05	APPLICATION SPEC	HEADER ASSEMBLY, MOD II, BREAKAWAY, DOUBLE ROW, HIGH TEMPERATURE
4 PLC ± 0.127[.0005]	ANGLES ±	19JAN05	WEIGHT	SIZE CASE CODE DRAWING NO. RESTRICTED TO
MATERIAL	FINISH SEE TABLE	19JAN05	A1 00779C=146257	SCALE 4:1 SHEET 1 OF 1 REV M2

CUSTOMER DRAWING