

LOC		DIST		REVISIONS			
F	LTR	DESCRIPTION	DATE	DWN	APVD		
F		REVISED PER ECO-14-004696	11APR2014	NK	JO		

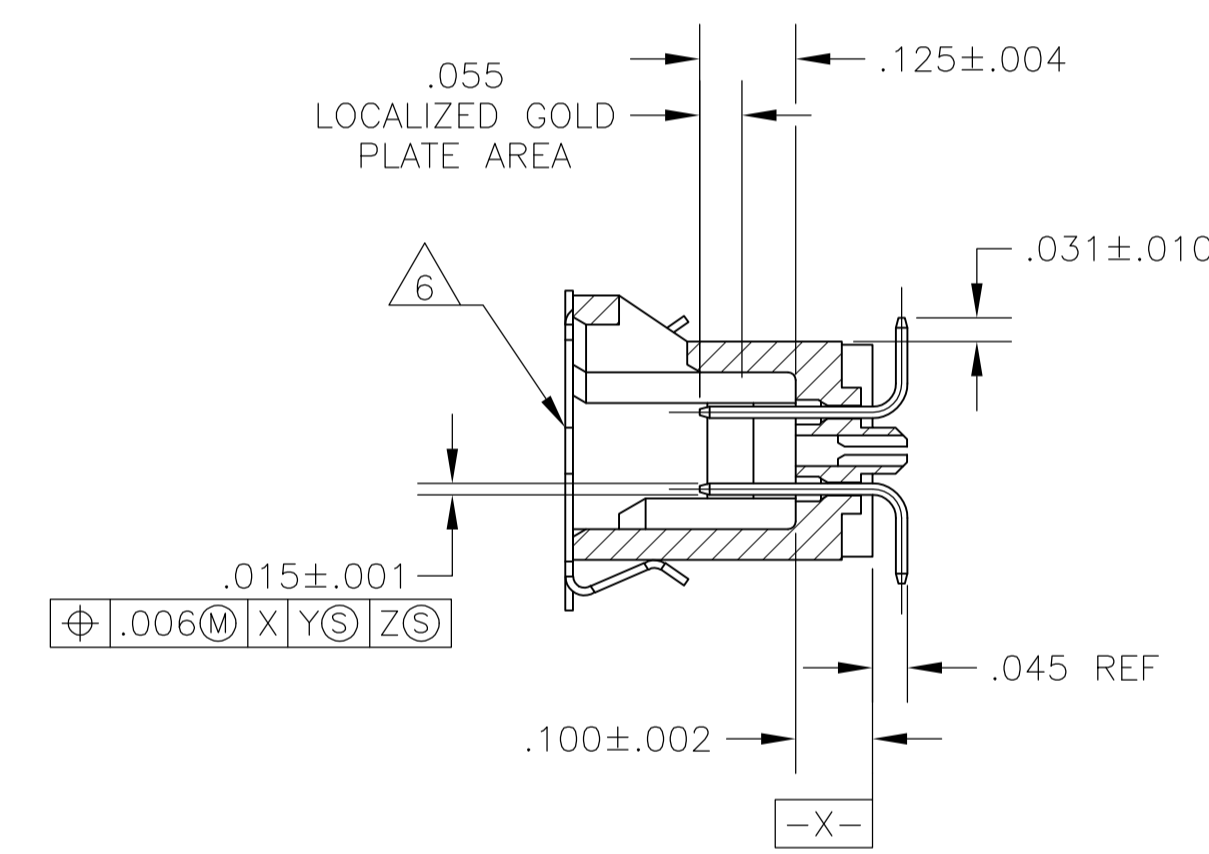

- 1 .000030 GOLD IN LOCALIZED PLATE AREA, .000150 TIN-LEAD ON SOLDER TAILS ALL OVER .000050 NICKEL.
- 2 CIRCUIT IDENTIFICATION FEATURE OMITTED ON 10 POSITION HEADER ASSEMBLIES.
- 3 DIMENSION APPLIES AT BASE OF SHROUD.
- 4 THE NOTED DIMENSIONS APPLY AT THE MATING FACE OF THE HOUSING.
- 5 (Y3) (Y4) ARE LOCATED THE SAME AS (Y1) (Y2) EXCEPT ON OPPOSITE SIDE OF HOUSING.
- 6 VACUUM COVER DESIGNED FOR .160 [4mm] DIA NOZZLE. VACUUM COVER TO BE REMOVED AFTER SOLDERING.
- 7 PACKAGED IN TAPE AND REEL PER EIA-481 SPECIFICATIONS. SEE CHART FOR TAPE WIDTHS.
- 8 .265 [6.75mm] MIN TARGET AREA FOR VACUUM PICK-UP.
- 9 HOUSING: PPA. CONTACT: PHOSPHOR BRONZE. VACUUM COVER: ALUMINUM
- 10 VACUUM COVER SHOWN IN PHANTOM LINE.
- 11 .000030 GOLD IN LOCALIZED PLATE AREA, .000150 TIN ON SOLDER TAILS, ALL OVER .000050 NICKEL.
- 12 OBSOLETE PARTS: OBSOLETE CIS STREAMLINING PER D.RENAUD / D.SINISI
- 13 NO CIRCUIT IDENTIFICATION FEATURE ON 10,12,20,24 AND 30 POSITION PARTS.

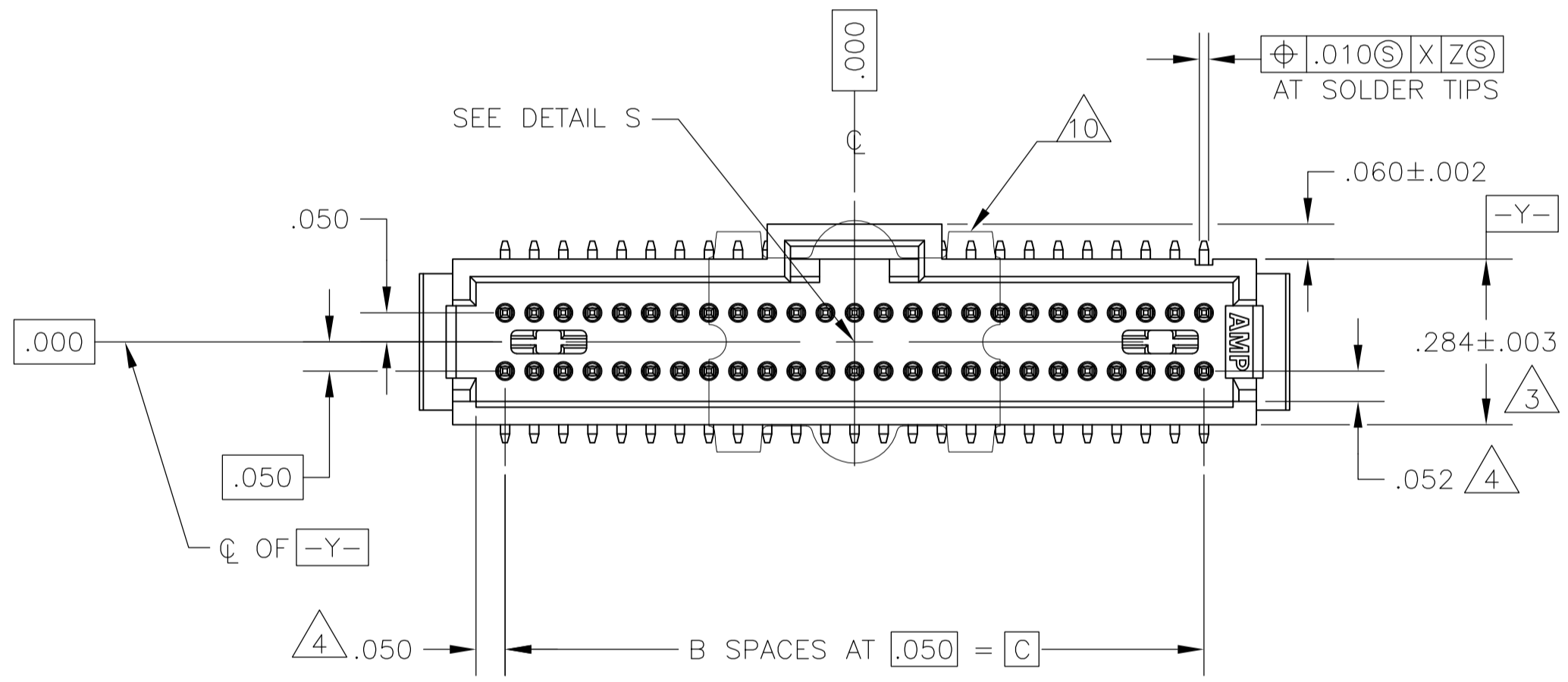
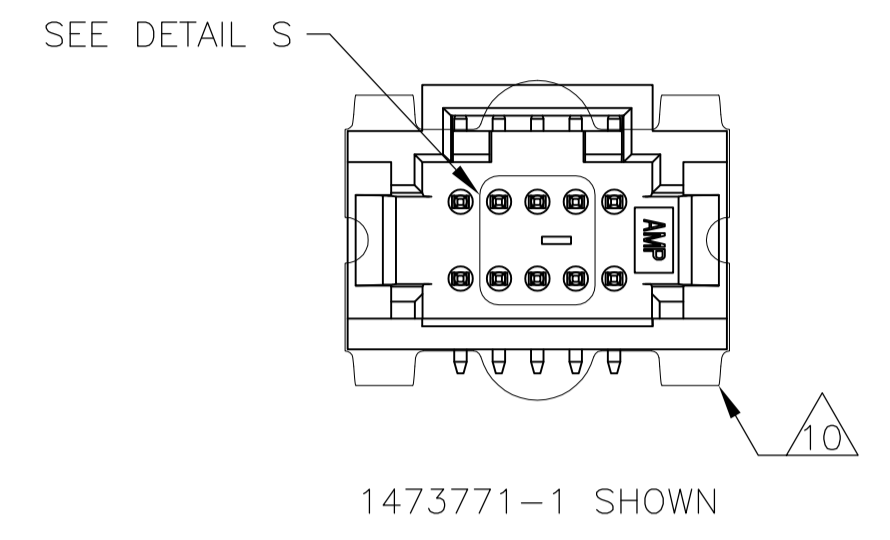
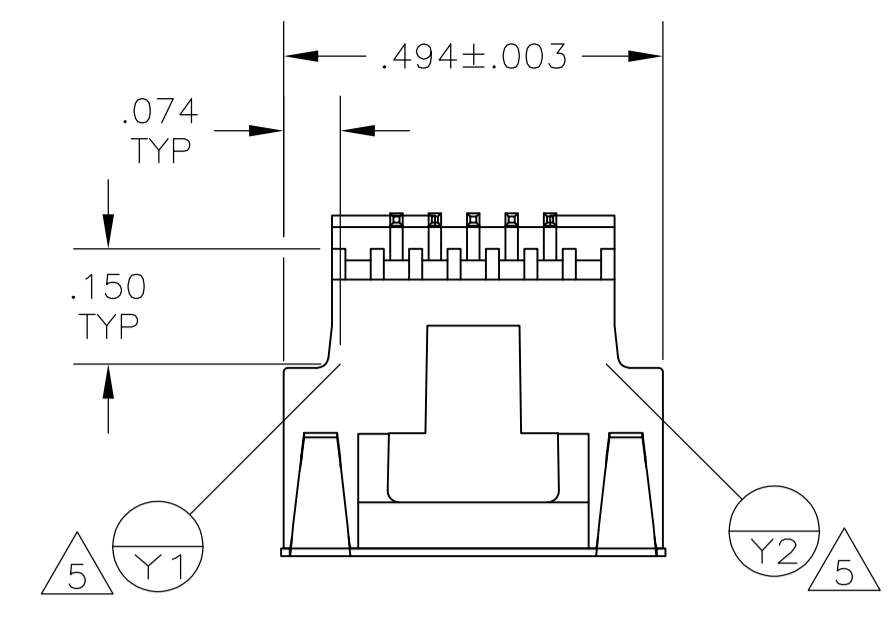
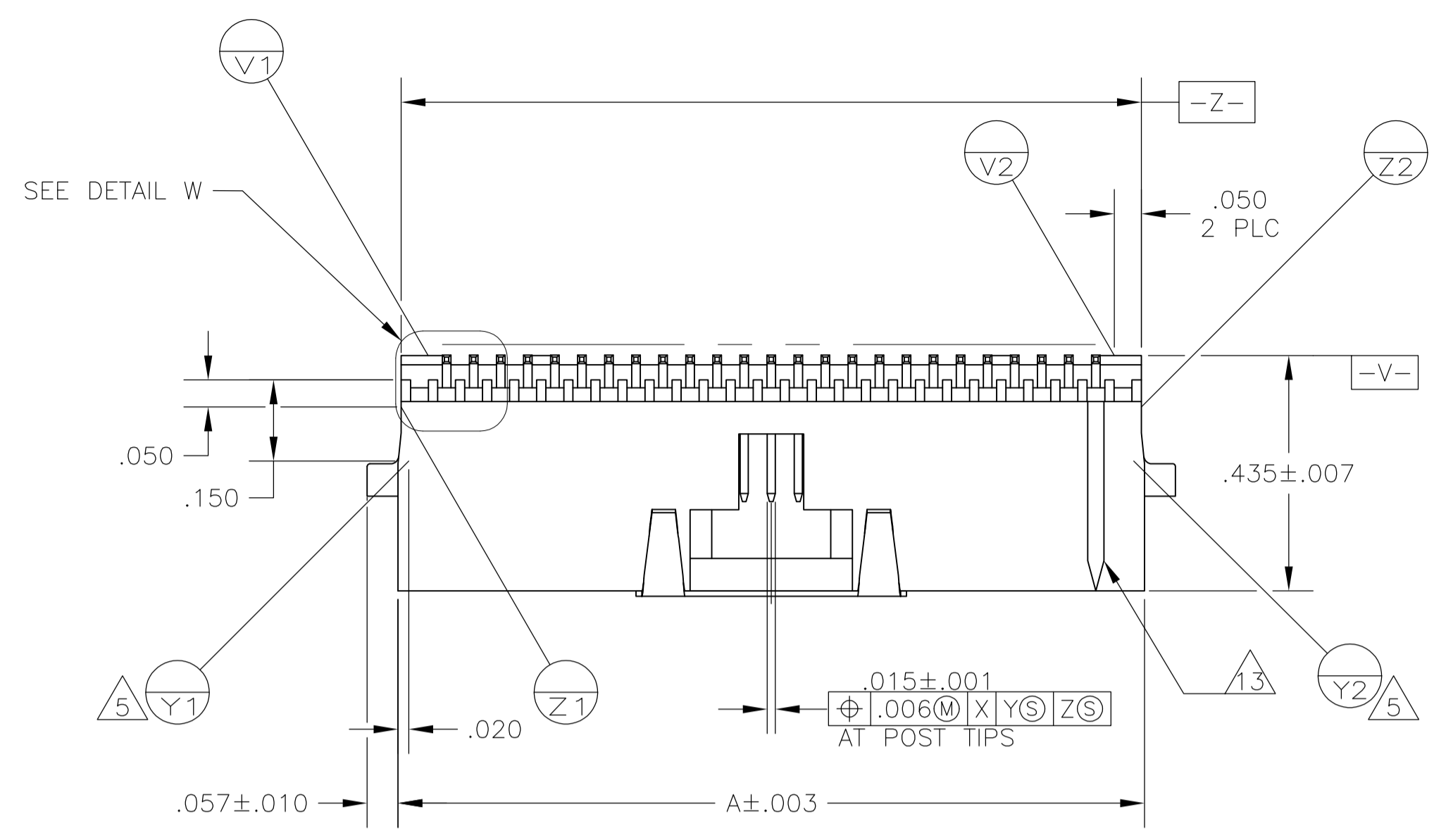
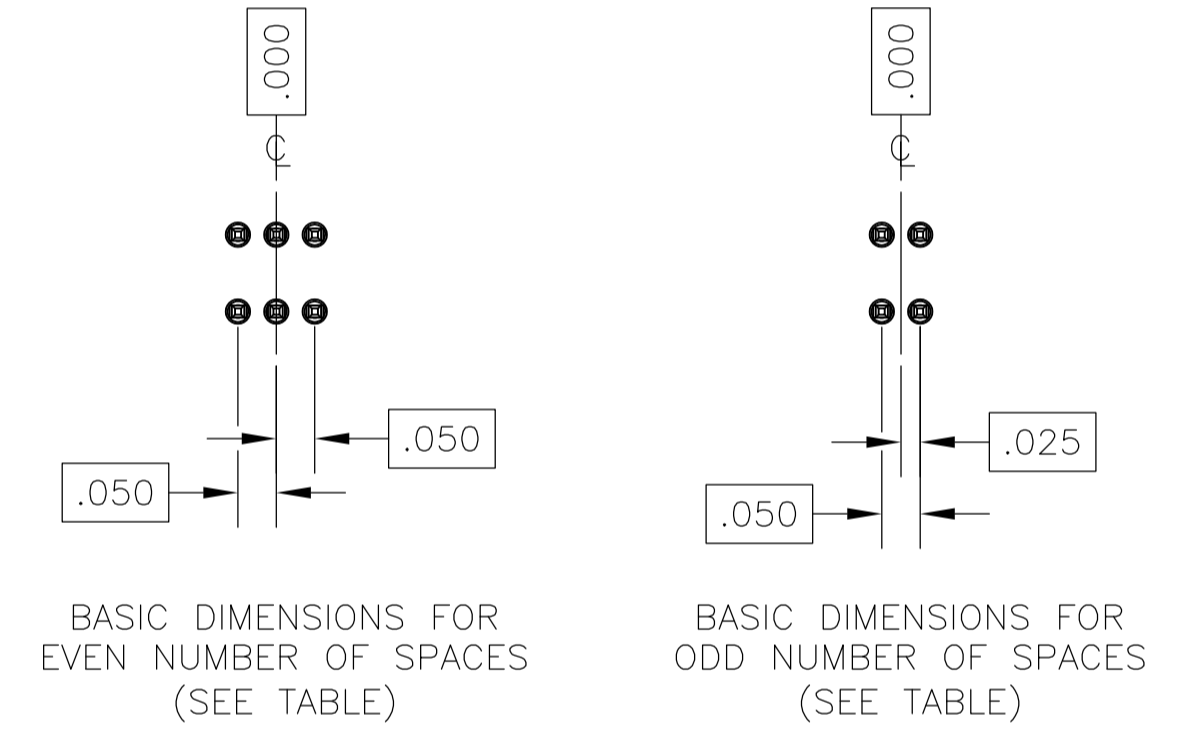

DETAIL S

- 14 FINISH: .000001 MIN GOLD ON GOLD PLATED AREA, .000150-.000250 MATTE TIN-LEAD ON TIN PLATED AREA. UNDER PLATING TO BE .000050-.000100 NICKEL ON ENTIRE CONTACT
- 15 FINISH: .000001 MIN GOLD ON GOLD PLATED AREA, .000150-.000250 MATTE TIN ON TIN PLATED AREA. UNDER PLATING TO BE .000050-.000100 NICKEL ON ENTIRE CONTACT
- 16 PRELIMINARY - NOT FOR PRODUCTION

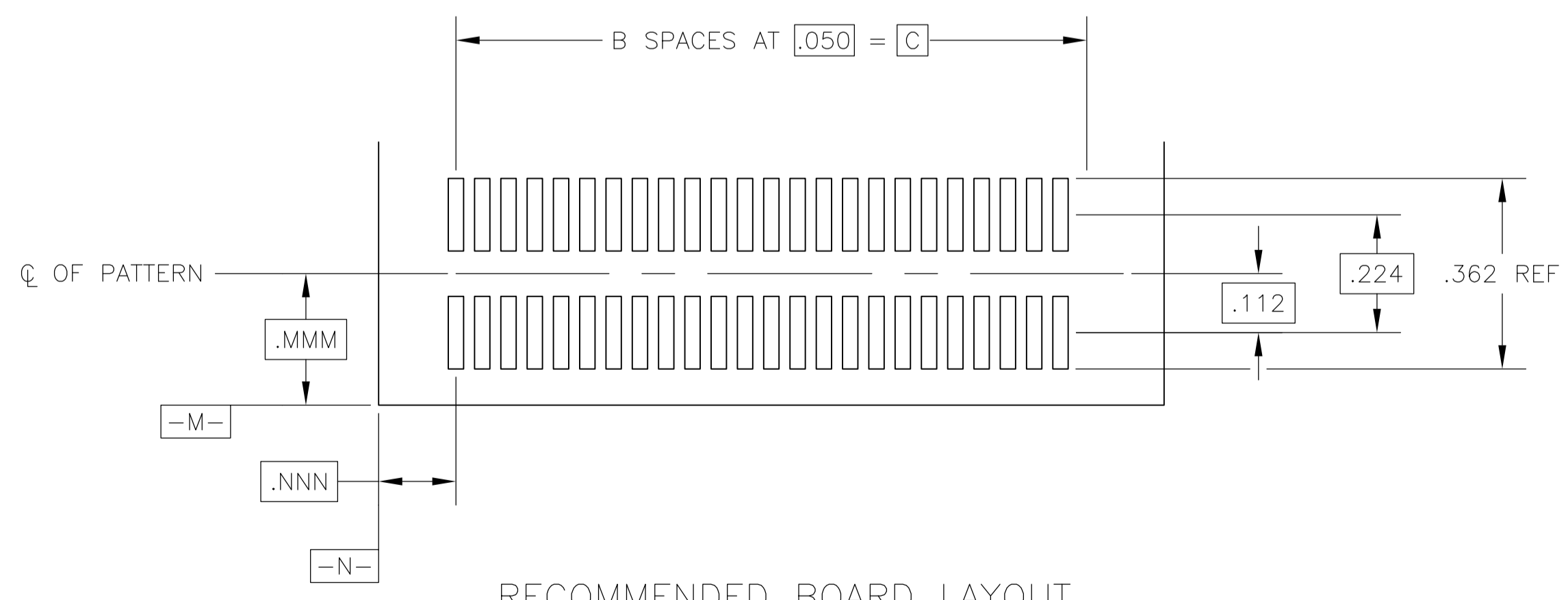

RECOMMENDED BOARD LAYOUT

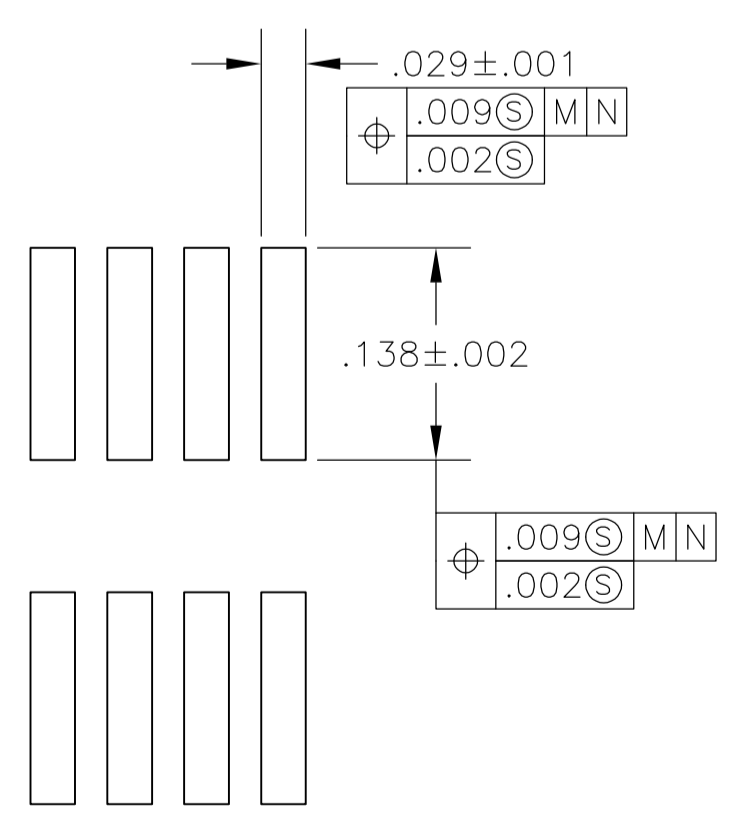

DETAIL G SCALE 8:1

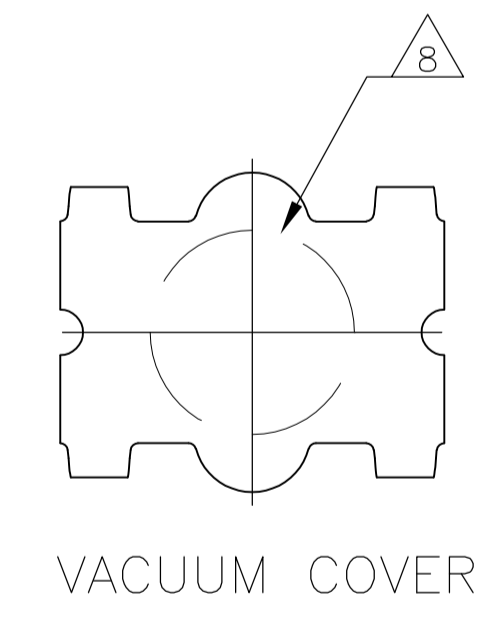

VACUUM COVER

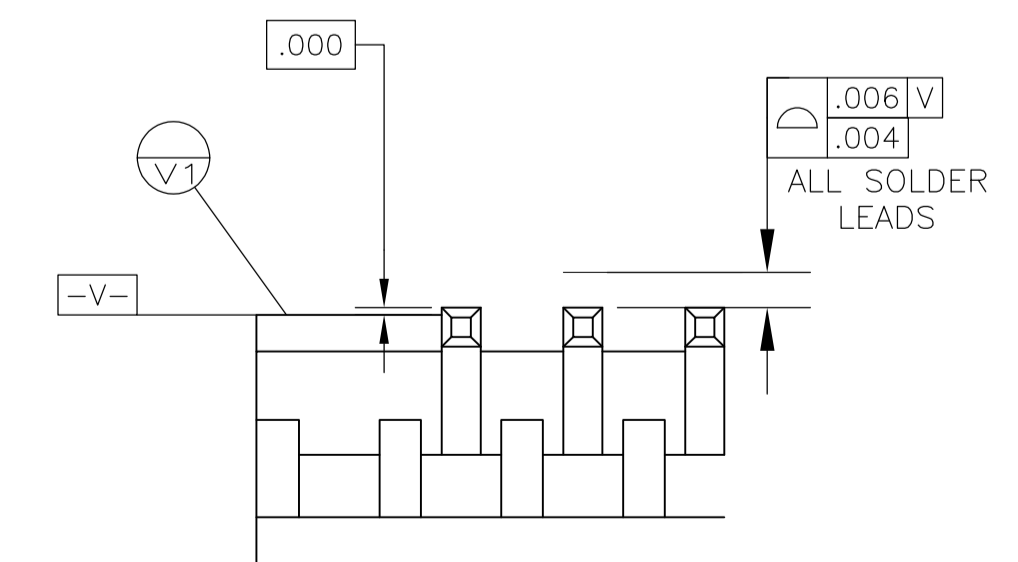

DETAIL W

THIS DRAWING IS A CONTROLLED DOCUMENT.		DIN B HAYMAKER 17JAN00	TE Connectivity
DIMENSIONS: INCHES		CHK J. MOSIER 17JAN00	
TOLERANCES UNLESS OTHERWISE SPECIFIED:		APVD J. MOSIER 17JAN00	NAME
0 PLC ± -			HEADER ASSEMBLY, W/SIDE & END LATCHES, VERTICAL, SHROUDED, DOUBLE ROW, SURFACE MOUNT
1 PLC ± -			PRODUCT SPEC
2 PLC ± -			108-1093
3 PLC ± .005			APPLICATION SPEC
4 PLC ± -			114-25035
ANGLES ± -			SIZE CAGE CODE DRAWING NO RESTRICTED TO
			A1 00779 C=147377
MATERIAL	FINISH	WEIGHT	
9	SEE NOTES		
CUSTOMER DRAWING		SCALE 4:1	SHEET 1 OF 2 REV F

15	56MM	1.050	21	1.230	44	16	8-147377-0	
	44mm	.550	11	.730	24	16	7-147377-9	
	88mm	2.450	49	2.630	100		7-147377-8	
	88mm	1.950	39	2.130	80	16	7-147377-7	
	72mm	1.450	29	1.630	60	16	7-147377-6	
	56mm	1.200	24	1.380	50	16	7-147377-5	
	56mm	.950	19	1.130	40	16	7-147377-4	
	56mm	.700	14	.880	30	16	7-147377-3	
	44mm	.450	9	.630	20	16	7-147377-2	
	32mm	.200	4	-	10		7-147377-1	
	11	56MM	1.050	21	1.230	44	12	6-147377-0
		44mm	.550	11	.730	24		5-147377-9
		88mm	2.450	49	2.630	100		5-147377-8
88mm		1.950	39	2.130	80		5-147377-7	
72mm		1.450	29	1.630	60		5-147377-6	
56mm		1.200	24	1.380	50		5-147377-5	
56mm		.950	19	1.130	40		5-147377-4	
56mm		.700	14	.880	30		5-147377-3	
44mm		.450	9	.630	20		5-147377-2	
32mm	.200	4	-	10		5-147377-1		
FINISH	TAPE WIDTHS	C	B	A	NO OF POSN	PART NUMBER		

14	56MM	1.050	21	1.230	44	16	3-147377-0	
	44mm	.550	11	.730	24	16	2-147377-9	
	88mm	2.450	49	2.630	100		2-147377-8	
	88mm	1.950	39	2.130	80	16	2-147377-7	
	72mm	1.450	29	1.630	60	16	2-147377-6	
	56mm	1.200	24	1.380	50	16	2-147377-5	
	56mm	.950	19	1.130	40	16	2-147377-4	
	56mm	.700	14	.880	30	16	2-147377-3	
	44mm	.450	9	.630	20	16	2-147377-2	
	32mm	.200	4	-	10	16	2-147377-1	
	1	56MM	1.050	21	1.230	44	12	1-147377-0
		44mm	.550	11	.730	24		147377-9
		88mm	2.450	49	2.630	100		147377-8
88mm		1.950	39	2.130	80		147377-7	
72mm		1.450	29	1.630	60		147377-6	
56mm		1.200	24	1.380	50		147377-5	
56mm		.950	19	1.130	40		147377-4	
56mm		.700	14	.880	30		147377-3	
44mm		.450	9	.630	20		147377-2	
32mm	.200	4	-	10		147377-1		
FINISH	TAPE WIDTHS	C	B	A	NO OF POSN	PART NUMBER		

THIS DRAWING IS A CONTROLLED DOCUMENT.		DWG: B. HAYMAKER 17JAN00	 TE Connectivity
DIMENSIONS: INCHES		CHK: J. MOSIER 17JAN00	
TOLERANCES UNLESS OTHERWISE SPECIFIED:		APVD: J. MOSIER 17JAN00	NAME: HEADER ASSEMBLY, W/SIDE & END LATCHES, VERTICAL, SHROUDED, DOUBLE ROW, SURFACE MOUNT AMPMODU System 50, W/O HOLDDOWNS
0 PLC ± - 1 PLC ± - 2 PLC ± - 3 PLC ± .005 4 PLC ± - ANGLES ± -		PRODUCT SPEC: 108-1093	RESTRICTED TO: -
MATERIAL: 9		APPLICATION SPEC: 114-25035	SIZE: A1
FINISH: SEE NOTES		WEIGHT: -	SCALE: 4:1
CUSTOMER DRAWING		SIZE: A1	SHEET 2 OF 2
		REV: 1	REV: F