

LOC		DIST		REVISIONS			
P	LTR	DESCRIPTION	DATE	DWN	APVD		
A		REVISED PER EC 0514-0150-05	10OCT2005	REH	JL		

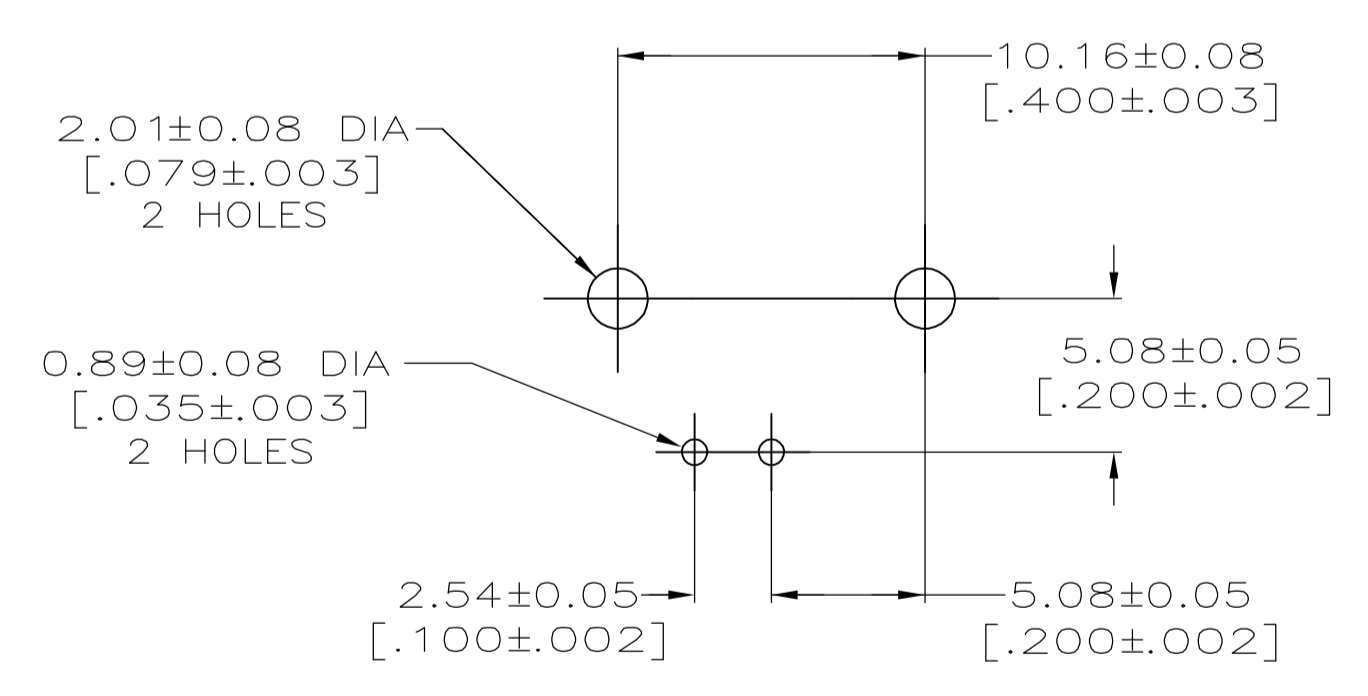
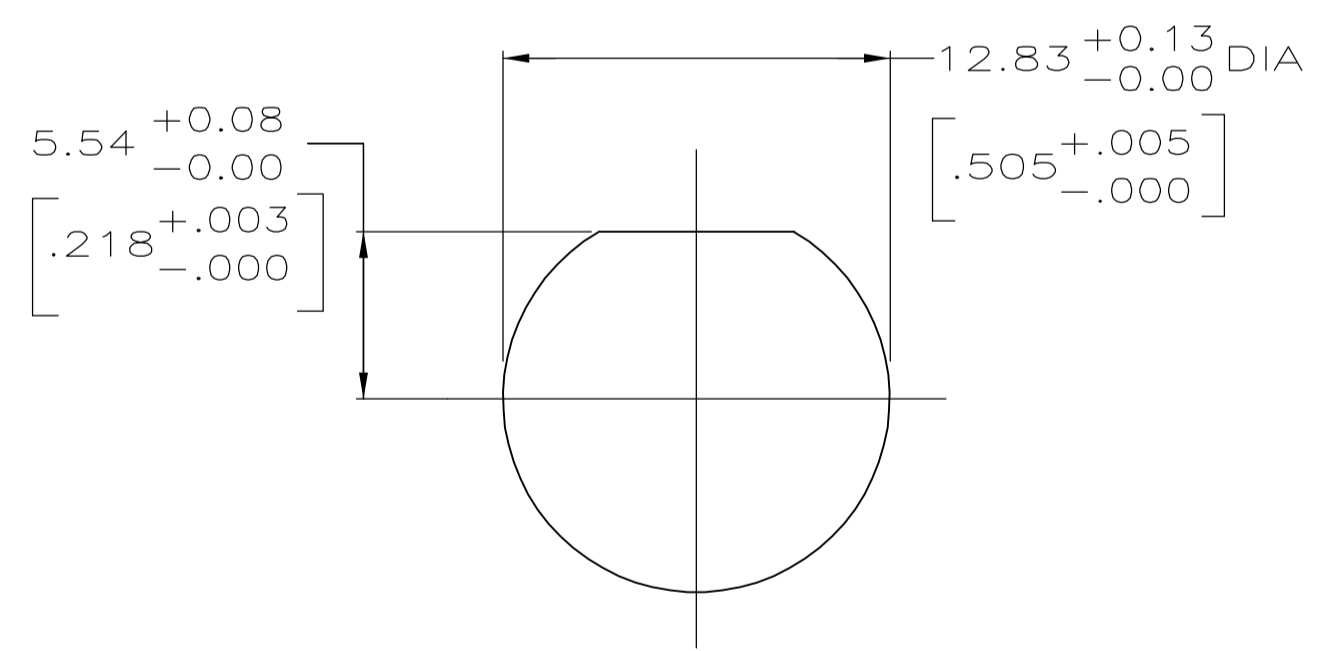
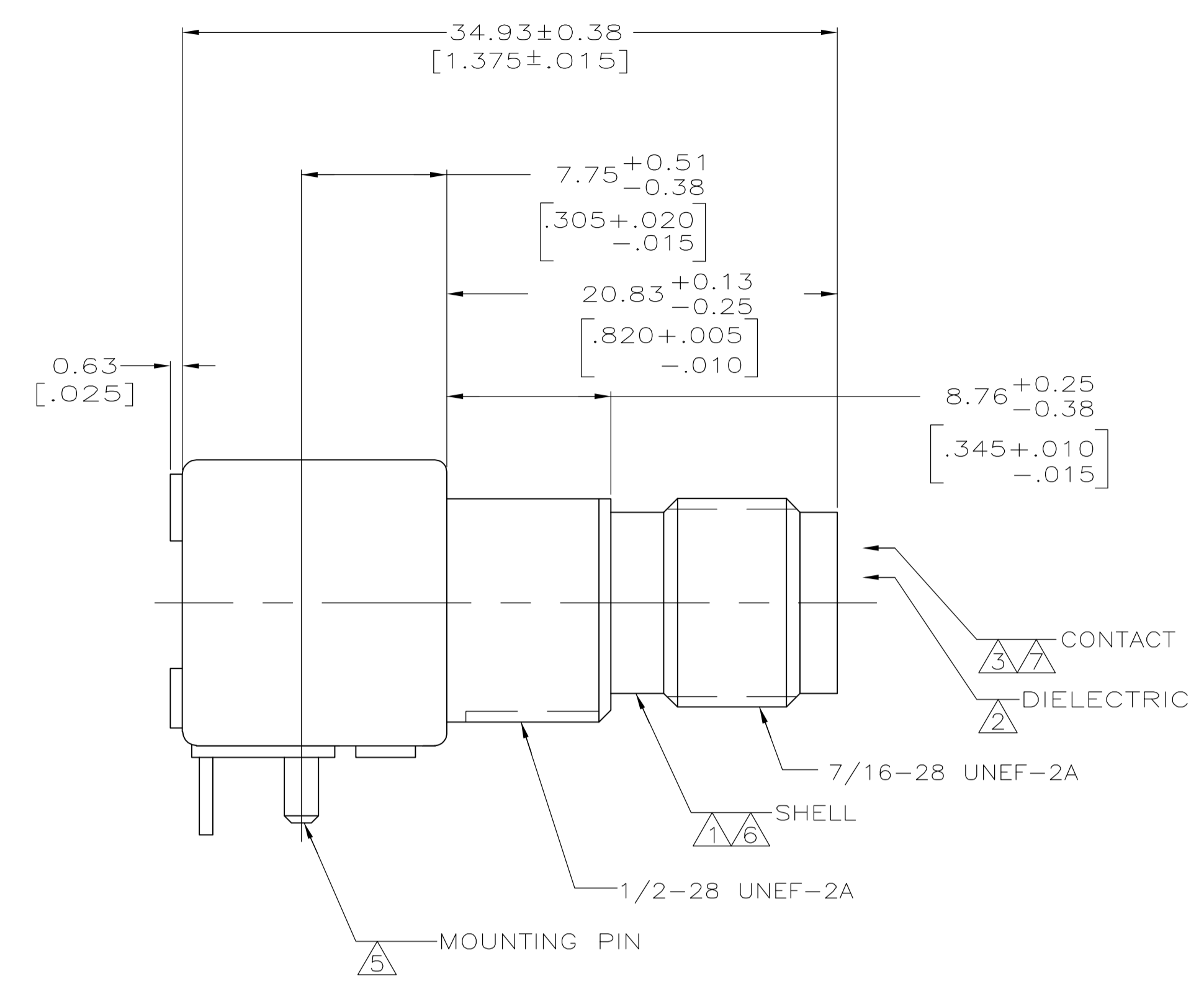
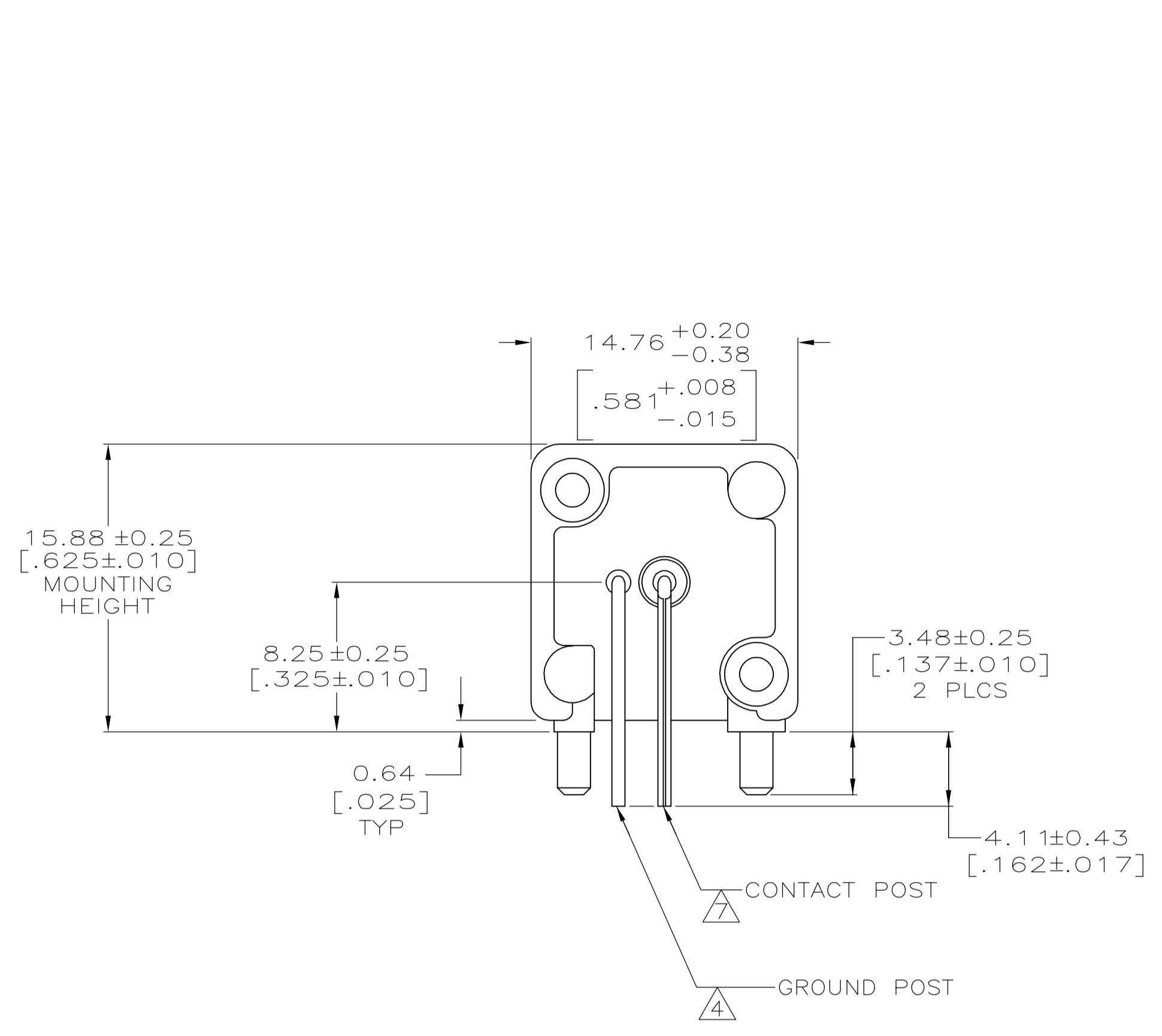

- ① ZINC PER QQ-Z-363.
- ② POLYMETHYLPENTENE, GENERAL PURPOSE.
- ③ PHOSPHOR BRONZE PER QQ-B-750.
- ④ BRASS PER ASTM-B-453.
- ⑤ BRASS PER ASTM-B-16.
- ⑥ NICKEL PLATE PER QQ-N-290, 3.81 μm [.000150] MINIMUM THICK.
- ⑦ GOLD PLATE PER MIL-G-45204, 0.76 μm [.000030] MINIMUM THICK.

5227839-1
 PART NUMBER

THIS DRAWING IS A CONTROLLED DOCUMENT.		DWN L. VARELA - 21APR2005	Tyco Electronics Corporation Harrisburg, PA 17105-3608	
DIMENSIONS: mm [INCHES]		CHK J. HAVENER - 21APR2005	NAME J. LIPPERT - 21APR2005	
TOLERANCES UNLESS OTHERWISE SPECIFIED:		PRODUCT SPEC		
0 PLC ± -		APPLICATION SPEC		
1 PLC ± -		RESTRICTED TO		
2 PLC ± 0.20 [.008]		SIZE CAGE CODE DRAWING NO		
3 PLC ± -		A1 00779 ©=5227839		
4 PLC ± -		CUSTOMER DRAWING		
ANGLES ± -		SCALE 4:1 SHEET 1 of 1 REV A		
FINISH SEE NOTES 5-7		WEIGHT -		