

THIS DRAWING IS UNPUBLISHED. RELEASED FOR PUBLICATION
 © COPYRIGHT - BY TYCO ELECTRONICS CORPORATION. ALL RIGHTS RESERVED.

LOC	DIST	REVISIONS			
P	LTR	DESCRIPTION	DATE	DWN	APVD
G	14	G1	REV PER ECR 07-006018	20MAR07	JR TM

AMP
WIRE RANGE

12-10 AWG
SOLID OR STRANDED

- 1 STAMP 8S AMP 12-10* APPROX AS SHOWN
- 2 WIRE INSULATION DIA .150-.250
- 3 TONGUE MATERIAL THICKNESS .039±.002
- 4 MATERIAL: BODY - PHOS BRONZE PER ASTM B103
PLASTIC SLEEVE - NYLON, COLOR-YELLOW
METAL SLEEVE - COPPER PER ASTM B152
- 5 FINISH: BODY - TIN PLATE PER ASTM B545
METAL SLEEVE - TIN PLATE PER ASTM B545
- 6 DIMENSION APPLIES FROM EDGE OF METAL WIRE BARREL TO CENTER OF STUD.

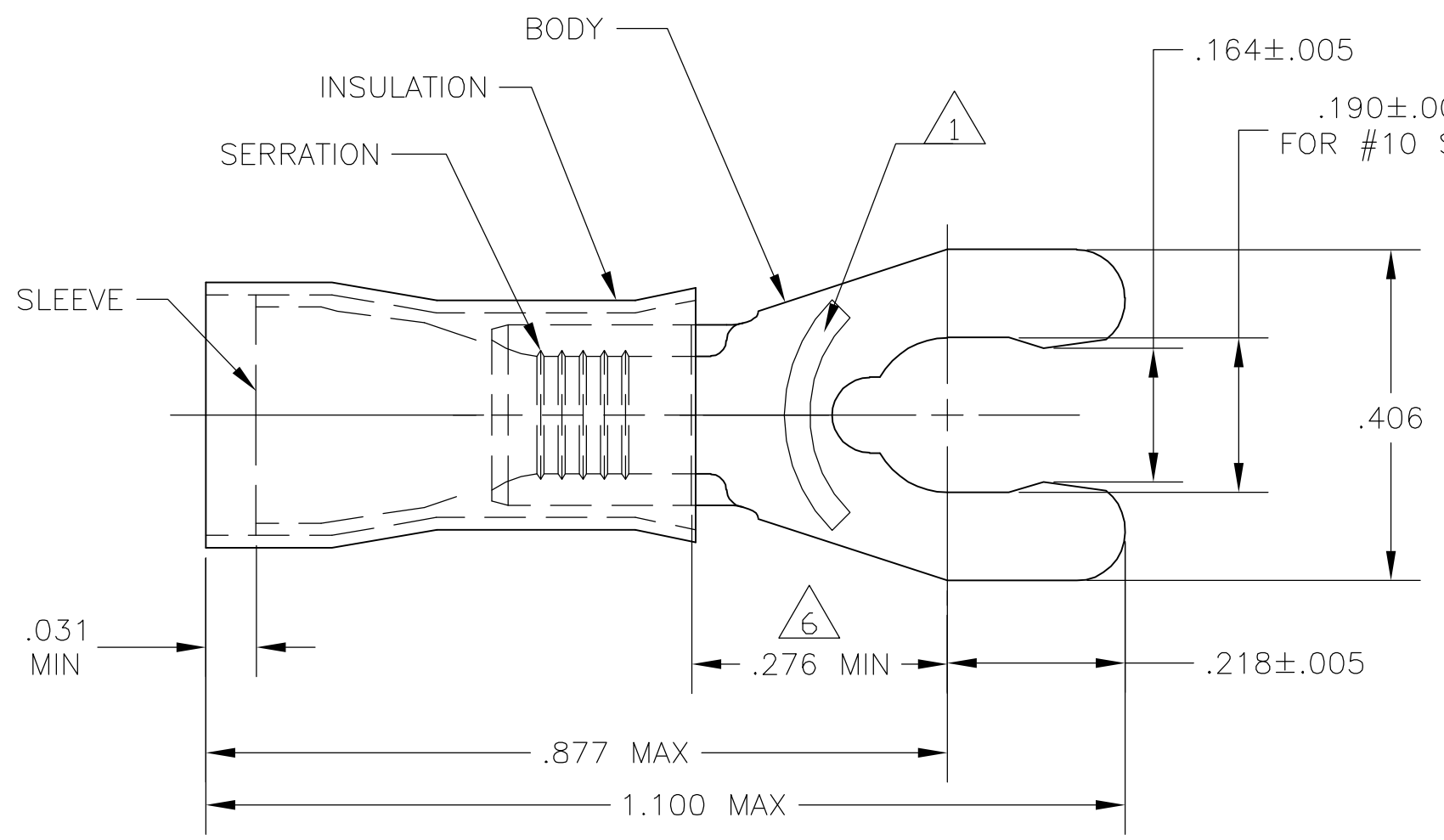

100	LOOSE PC, BOX	8-52943-1
1	ON TAPE	52943-1
1	LOOSE PIECE	52943
QTY	PACKAGE TYPE	PART NO

THIS DRAWING IS A CONTROLLED DOCUMENT.		DWN jr_ruth 20MAR07	Tyco Electronics Corporation Harrisburg, PA 17105-3608	
DIMENSIONS: INCHES		CHK T MICHIELUTTI 20MAR07		
		APVD T MICHIELUTTI 20MAR07	NAME TERMINAL, SPRING SPADE, STUB, PIDG WIRE SIZE: 12-10	
TOLERANCES UNLESS OTHERWISE SPECIFIED:		PRODUCT SPEC	RESTRICTED TO	
0 PLC ± -		APPLICATION SPEC	SIZE	CAGE CODE
1 PLC ± -		WEIGHT	A3	00779
2 PLC ± -		CUSTOMER DRAWING	DRAWING NO C=52943	
3 PLC ± .008		SCALE	5:1	SHEET
4 PLC ± -		SCALE	5:1	1 OF 1
ANGLES ± 5°		REV	G1	
MATERIAL				
FINISH				
- 4				
- 5				