

PRODUCT SPECIFICATION

1. SCOPE

1.1. Content

This specification covers the performance, tests and quality requirements for the AMP\* Low Profile Shunt connector. This connector is a separable, electrical connection device for mating with two .025 square posts. Two sizes are available for posts on either .100 or .200 inch spacing.

1.2. Qualification

When tests are performed on the subject product line, the procedures specified in AMP 109 series specifications shall be used. All inspections shall be performed using the applicable inspection plan and product drawing.

2. APPLICABLE DOCUMENTS

The following documents form a part of this specification to the extent specified herein. In the event of conflict between the requirements of this specification and the product drawing, the product drawing shall take precedence. In the event of conflict between the requirements of this specification and the referenced documents, this specification shall take precedence.

2.1. AMP Documents

- A. 109-1: General Requirements for Test Specifications
- B. 109 Series: Test Specifications as indicated in Figure 1. (Comply with MIL-STD-202, MIL-STD-1344 and EIA RS-364)
- C. Corporate Bulletin 401-76: Cross-reference between AMP Test Specifications and Military or Commercial Documents
- D. 114-1059 : Application Specification
- E. 501-141 : Test Report

3. REQUIREMENTS

3.1. Design and Construction

Product shall be of the design, construction and physical dimensions specified on the applicable product drawing.

\*Trademark of AMP Incorporated

Product Code: 5239

COPYRIGHT IS 80, 84, 90  
 BY AMP INCORPORATED  
 ALL INTERNATIONAL RIGHTS RESERVED.

				DR <i>David Ruchardt 4/15/91</i>	<b>AMP</b> AMP Incorporated Harrisburg, PA 17105-3608		
				CHK <i>D. Hoffman 4/19/91</i>			
				APP <i>J. Gray 4/19/91</i>			
0	Release per ECN AG-2259	<i>FK</i>	4/22 91	PAGE 1 OF 10	TITLE CONNECTOR, LOW PROFILE, SHUNT		
LTR	REVISION RECORD	APP	DATE				

### 3.2. Materials

- A. Contact: Beryllium copper, tin plated or localized gold over nickel.
- B. Housing: Glass filled polyester, UL 94V-0

### 3.3. Ratings

- A. Current: See Figure 2 for current carrying capability
- B. Temperature:
  - (1) -65° to 105°C for gold
  - (2) -40° to 85°C for tin

### 3.4. Performance and Test Description

The product is designed to meet the electrical, mechanical and environmental performance requirements specified in Figure 1. All tests are performed at ambient temperature unless otherwise specified.

### 3.5. Test Requirements and Procedures Summary

Test Description	Requirement	Procedure										
Examination of Product	Meets requirements of product drawing and AMP Spec 114-1059.	Visual, dimensional and functional per applicable quality inspection plan.										
<b>ELECTRICAL</b>												
Termination Resistance, Specified Current	<table border="0"> <tr> <td>Test current</td> <td>Resistance maximum</td> </tr> <tr> <td><u>ampere</u></td> <td><u>milliohms</u></td> </tr> <tr> <td>3</td> <td>10 initial</td> </tr> <tr> <td></td> <td>20 final gold</td> </tr> <tr> <td></td> <td>30 final tin</td> </tr> </table>	Test current	Resistance maximum	<u>ampere</u>	<u>milliohms</u>	3	10 initial		20 final gold		30 final tin	Measure potential drop of assembly mated to a pin header; AMP Spec 109-25, calculate resistance.
Test current	Resistance maximum											
<u>ampere</u>	<u>milliohms</u>											
3	10 initial											
	20 final gold											
	30 final tin											
Termination Resistance, Dry Circuit	10 milliohms maximum initial. 20 milliohms maximum final for gold; 30 milliohms maximum for tin.	Subject assembly mated to a pin header to 20 mv open circuit at 100 ma maximum, see Figure 4; AMP Spec 109-6-6.										
Dielectric Withstanding Voltage	1000 vac dielectric withstanding voltage, one minute hold. No breakdown or flashover.	Test between adjacent assemblies mated to posts; AMP Spec 109-29-1.										
Insulation Resistance	1000 megohms minimum .	Test between adjacent assemblies mated to header posts; AMP Spec 109-28-4.										
Temperature Rise vs Current	30°C maximum temperature rise at specified current.	Measure temperature rise vs current; AMP Spec 109-45-1. Reference Figure 2.										

Figure 1 (cont)

<b>AMP</b>	AMP Incorporated Harrisburg, PA 17105-3608	PAGE	NO	REV	LOC
		2	108-9057	0	B

Test Description	Requirement	Procedure						
<b>MECHANICAL</b>								
Vibration Sinusoidal High Frequency	No discontinuities greater than 1 microsecond. See note (a).	Subject assemblies mated to header posts to 15 G's, between 10-2000 Hz traversed in 20 minutes; 4 hours in each of 3 mutually perpendicular planes; AMP Spec 109-21-3. Reference Figure 6.						
Physical Shock	No discontinuities greater than 1 microsecond. See note (a).	Subject assemblies mated to header posts to 100 G's sawtooth shock pulses of 6 millisecond duration; 3 shocks in each direction applied along the 3 mutually perpendicular planes total 18 shocks; AMP Spec 109-26-9. Reference Figure 6.						
Engaging Force	43 ounces maximum for gold; 55 ounces maximum for tin.	Measure force necessary to engage gage 1, see Figure 5; incorporating free floating fixtures at a rate of 0.5 inch/minute; AMP Spec 109-35.						
Separating Force	5.4 ounces minimum.	Measure force necessary to separate gage 2, see Figure 5, at a rate of 0.5 inch/minute; AMP Spec 109-35.						
Durability	See note (a)	Engage and separate assembly with gage 3, see Figure 5, for number of cycles indicated, at a maximum rate of 3600 cycles/hour; AMP Spec 109-27. See Figure 3. <table border="0" data-bbox="1123 1411 1420 1501"> <tr> <td><u>Plating</u></td> <td><u>Cycles</u></td> </tr> <tr> <td>Gold</td> <td>25</td> </tr> <tr> <td>Tin</td> <td>5</td> </tr> </table>	<u>Plating</u>	<u>Cycles</u>	Gold	25	Tin	5
<u>Plating</u>	<u>Cycles</u>							
Gold	25							
Tin	5							

Figure 1 (cont)

<b>AMP</b> AMP Incorporated Harrisburg, PA 17105-3608	PAGE	NO	REV	LOC
	3	108-9057	0	B

Test Description	Requirement	Procedure
ENVIRONMENTAL		
Thermal Shock	See note (a)	Subject assemblies mated to header posts to 5 cycles between -65° and 105°C for gold and -40 and 85°C for tin; AMP Spec 109-22.
Humidity-Temperature Cycling	See note (a)	Subject assemblies mated to header posts to 10 humidity-temperature cycles between 25° and 65°C at 95% RH; AMP Spec 109-23-3, cond. B.
Industrial Mixed Flowing Gas	See note (a).	Subject assemblies mated to header posts to environmental class III for 20 days; AMP Spec 109-85-3.
Temperature Life	See note (a)	Subject assemblies mated to header posts to temperature life at 85°C for 96 hours duration; AMP Spec 109-43.

(a) Shall meet visual requirements, show no physical damage, and shall meet requirements of additional tests as specified in the test sequence in Figure 3.

Figure 1 (end)

<b>AMP</b> AMP Incorporated Harrisburg, PA 17105-3608	PAGE	NO	REV	LOC
	4	108-9057	0	B

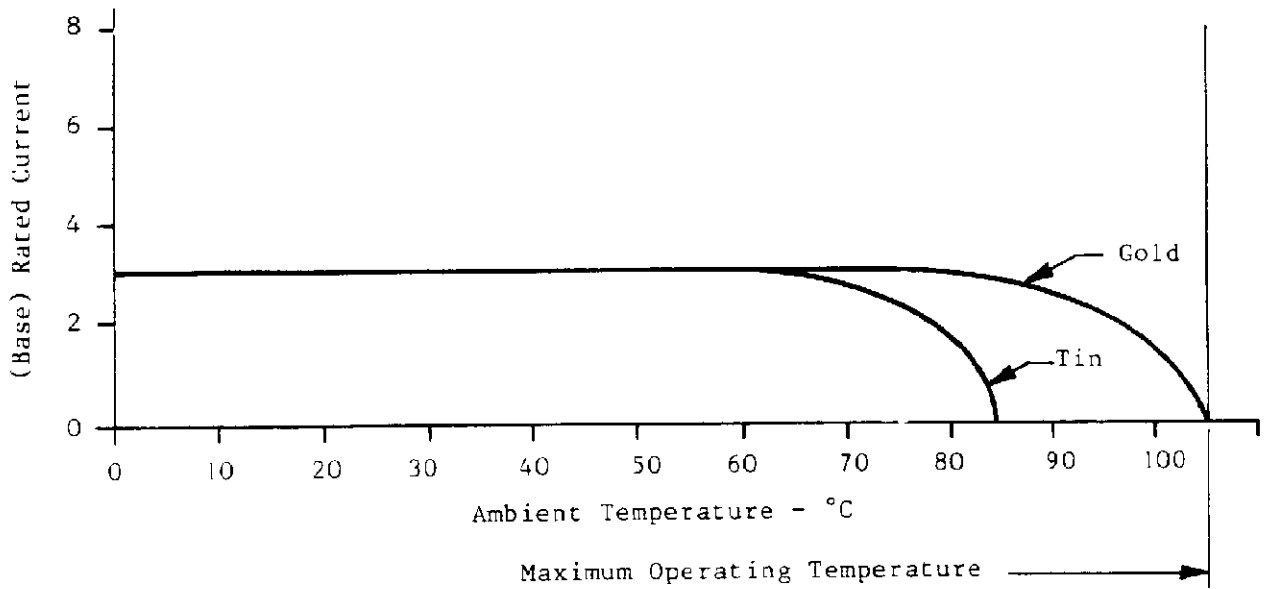

Figure 2  
Current Carrying Capability

### 3.6. Product Qualification and Requalification Tests

Test or Examination	Test Group (a)			
	1	2(f)	3(d)	4(g)
	Test Sequence (b)			
Examination of Product	1,9	1,11	1,8	1,11
Termination Resistance, Specified Current		3,10		3,10
Termination Resistance, Dry Circuit	3,7	2,8		2,8
Dielectric Withstanding Voltage			3,7	
Insulation Resistance			2,6	
Temperature Rise vs Rated Current		4,9		4,9
Vibration	5	7(c)		7(c)
Physical Shock	6			
Engaging Force	2			
Separating Force	8			
Durability	4			
Thermal Shock			4	
Humidity-Temperature Cycling			5	5(e)
Industrial Mixed Flowing Gas		5(e)		
Temperature Life		6		6

- (a) See Para 4.1.A
- (b) Numbers indicate sequence in which tests are performed.
- (c) Discontinuities shall not be measured. Energize at the 18°C level for 100% loading as determined in AMP Specification 109-151.
- (d) Group 3 applies only to products with an insulating system.
- (e) Precondition samples with 5 cycles durability.
- (f) For gold plated samples only
- (g) For tin plated samples only

Figure 3

#### 4. QUALITY ASSURANCE PROVISIONS

##### 4.1. Qualification Testing

###### A. Sample Selection

Samples shall be prepared in accordance with applicable Application Specification. They shall be selected at random from current production. All test groups shall consist of 10 tin plated and 10 gold plated shunts of each size. All shunts are to be mated to .025 square posts for testing. Square post headers may be mounted to printed circuit boards.

###### B. Test Sequence

Qualification inspection shall be verified by testing samples as specified in Figure 3.

**AMP**

AMP Incorporated  
Harrisburg, PA 17105-3608

PAGE NO

6

108-9057

REV LOC

0

B

#### 4.2. Requalification Testing

If changes significantly affecting form, fit, or function are made to the product or to the manufacturing process, product assurance shall coordinate requalification testing, consisting of all or part of the original testing sequence as determined by development/product, quality, and reliability engineering.

#### 4.3. Acceptance

Acceptance is based on verification that the product meets the requirements of Figure 1. Failures attributed to equipment, test setup, or operator deficiencies shall not disqualify the product. When product failure occurs, corrective action shall be taken and samples resubmitted for qualification. Testing to confirm corrective action is required before resubmittal.

#### 4.4. Quality Conformance Inspection

The applicable AMP quality inspection plan will specify the sampling acceptable quality level to be used. Dimensional and functional requirements shall be in accordance with the applicable product drawing and this specification.

**AMP**

AMP Incorporated  
Harrisburg, PA 17105-3608

PAGE NO

7

108-9057

REV LOC

0

**B**

Note: Post plating shall be identical to shunt plating when conducting tests.

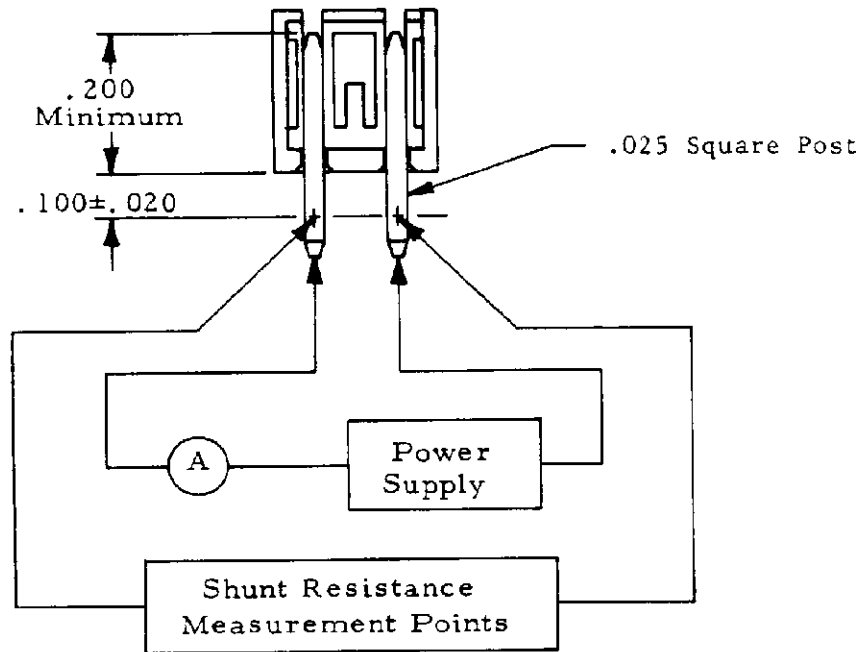
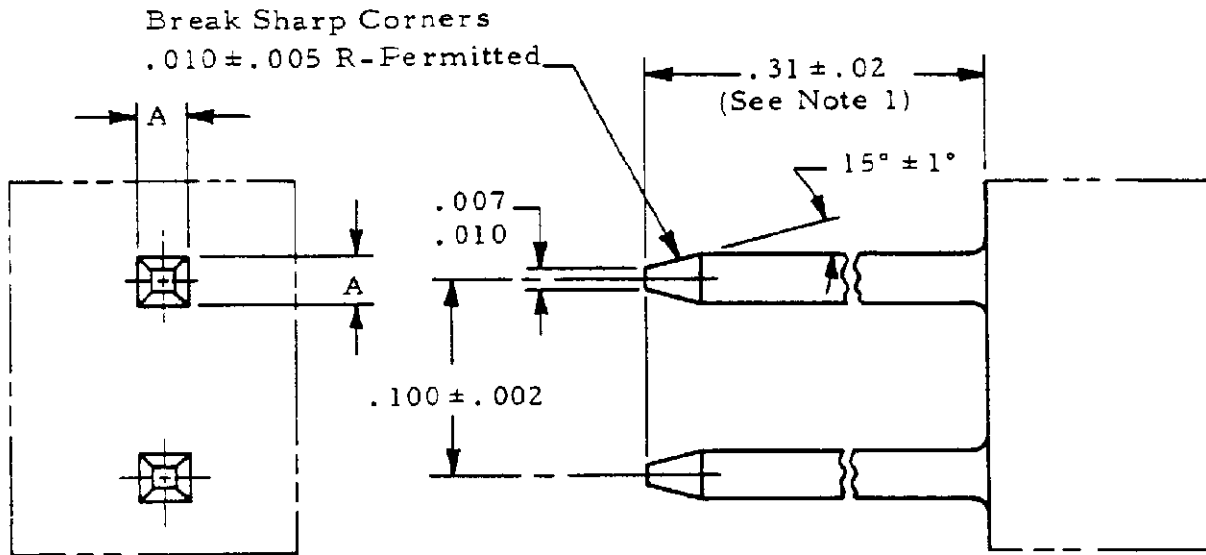

Figure 4  
Shunt Resistance Measurement Points





Gage	A
1	+ .0000
	.026 - .0001
2	+ .0001
	.024 - .0000
3	.025 ± .0001

Notes:

- (1) Finish in this area must be 4 microinches on all surfaces.
- (2) Material: Tool steel
- (3) Heat treat:  $R_c$  60 minimum

Figure 5  
 Shunt Post Simulator

Shunt Connector  
Fully Inserted  
and Aligned  
With Contacts

Header Mounted  
to P.C. Board

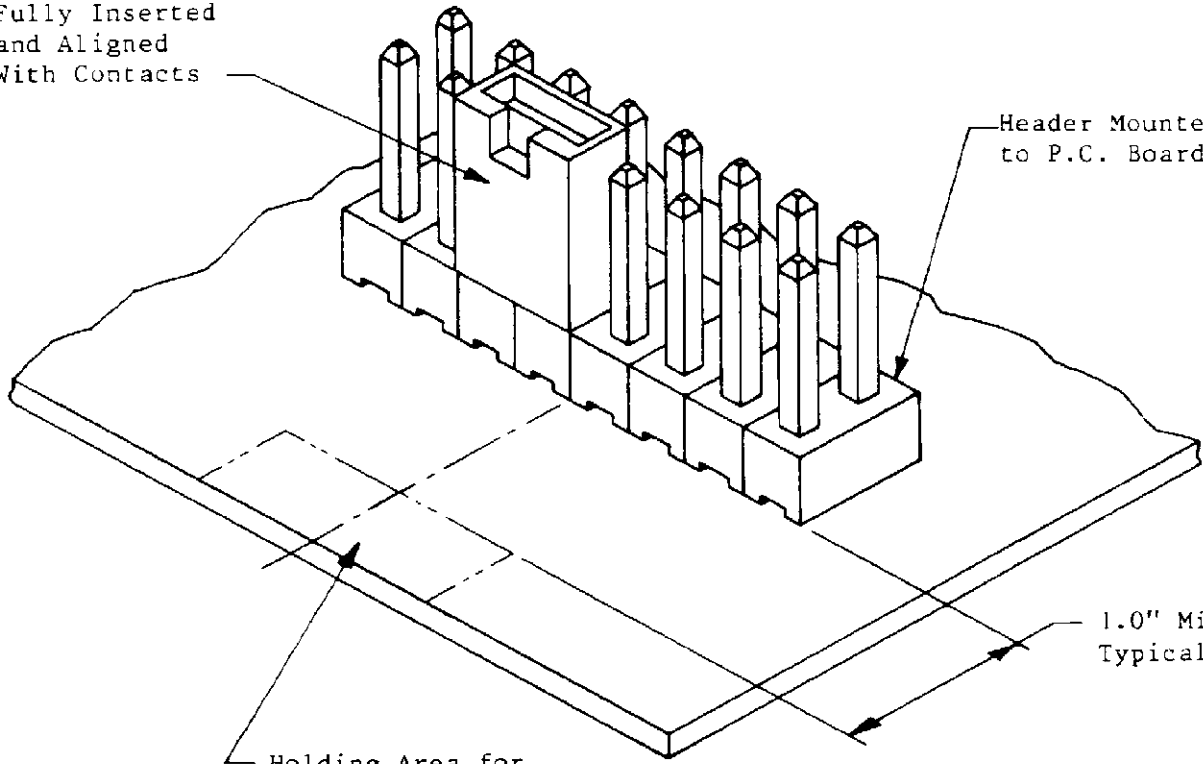

1.0" Minimum  
Typical

Holding Area for  
Vibration and  
Physical Shock

Holding Area for Vibration and Physical Shock  
Figure 6

**AMP**

AMP Incorporated  
Harrisburg, PA 17105-3608

PAGE NO

10

108-9057

REV LOC

0

**B**

Shunt Connector  
Fully Inserted  
and Aligned  
With Contacts

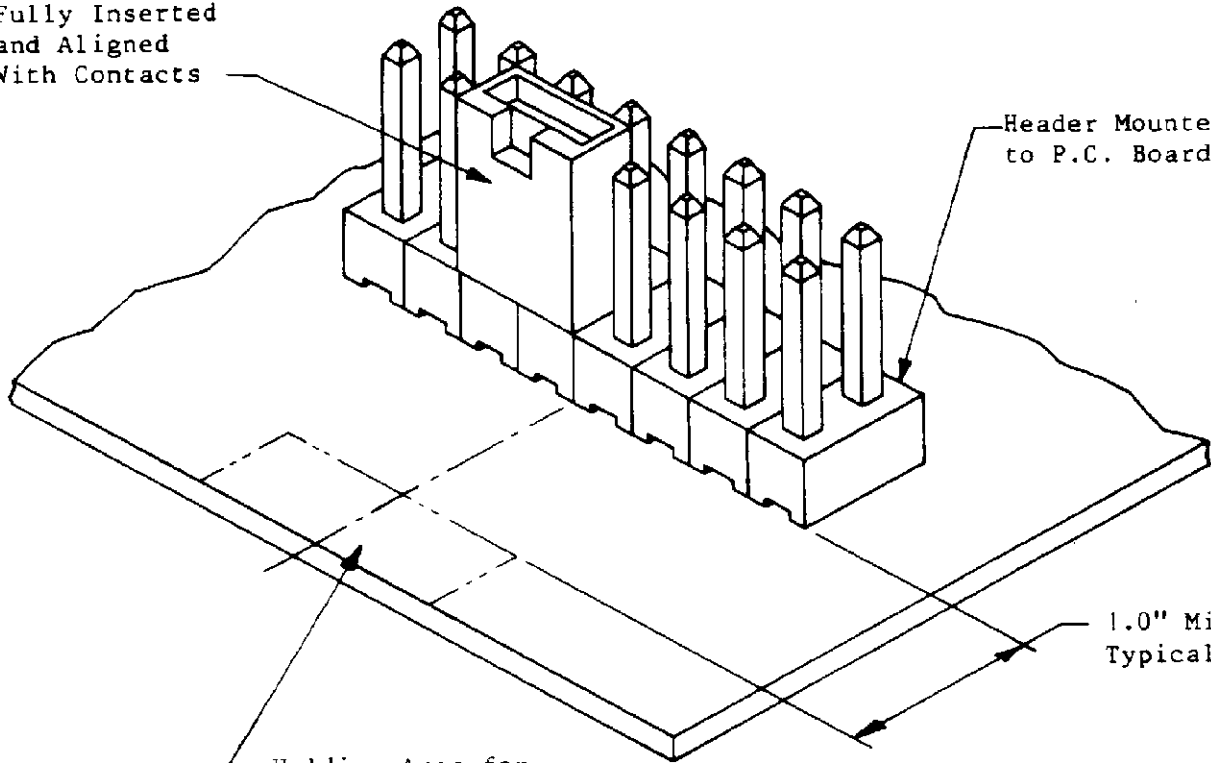

Header Mounted  
to P.C. Board

1.0" Minimum  
Typical

Holding Area for  
Vibration and  
Physical Shock

Holding Area for Vibration and Physical Shock  
Figure 7

**AMP**

AMP Incorporated  
Harrisburg, PA 17105-3608

PAGE NO  
11

108-9057

REV LOC  
0 B