

## 5332342 Product Details



**5332342**

TE Internal Number: 5332342



### Twin BNC RF Connectors

 Always EU RoHS/ELV Compliant (Statement of Compliance)

#### Product Highlights:

- Connector - RF
- Jack
- Coaxial Cable Type (RG/U or Mfg.) = 108, 108A
- Applies To Coaxial Cable
- With Panel Mount Retention

### Documentation & Additional Information

#### Product Drawings:

- [JACK, BHD, TWIN BNC](#) (PDF, English)

#### Catalog Pages/Data Sheets:

- [Twin BNC Connectors](#) (PDF, English)

#### Product Specifications:

- None Available

#### Application Specifications:

- None Available

#### Instruction Sheets:

- None Available

#### CAD Files: ([CAD Format & Compression Information](#))

- [2D Drawing](#) (DXF, Version A)
- [3D Model](#) (IGES, Version A)
- [3D Model](#) (STEP, Version A)

#### Related Products:

- [Tooling](#)

### Product Features (Please use the Product Drawing for all design activity)

#### Product Type Features:

- [Product Type](#) = Connector - RF
- [Gender](#) = Jack
- [Dielectric Material](#) = PTFE

#### Mechanical Attachment:

- [Panel Mount Retention](#) = With
- [Panel Mount Retention Type](#) = Bulkhead

#### Dimensions:

- [Panel Thickness](#) (mm [in]) = 3.18 [0.125]

#### Body Features:

- [Body Plating](#) = Silver

#### Contact Features:

- [Center Contact Plating](#) = Silver

#### Configuration Features:

- [Coaxial Cable Type \(RG/U or Mfg.\)](#) = 108, 108A

#### Industry Standards:

- [RoHS/ELV Compliance](#) = RoHS compliant, ELV compliant
- [Lead Free Solder Processes](#) = Not relevant for lead free process
- [RoHS/ELV Compliance History](#) = Always was RoHS compliant

#### Conditions for Usage:

- [Applies To](#) = Coaxial Cable

#### Other:

- [Brand](#) = TE Connectivity

- 1. CRIMP USING PRO-CRIMPER 354940-1 WITH DIE SET 91909-1.
- 2. PARTS PACKAGED UNASSEMBLED.

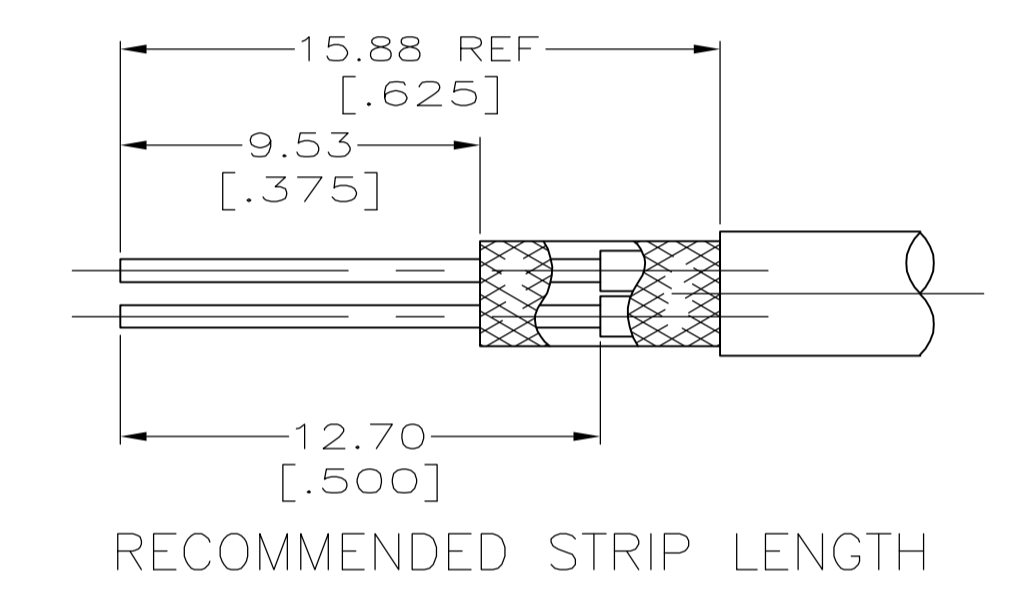
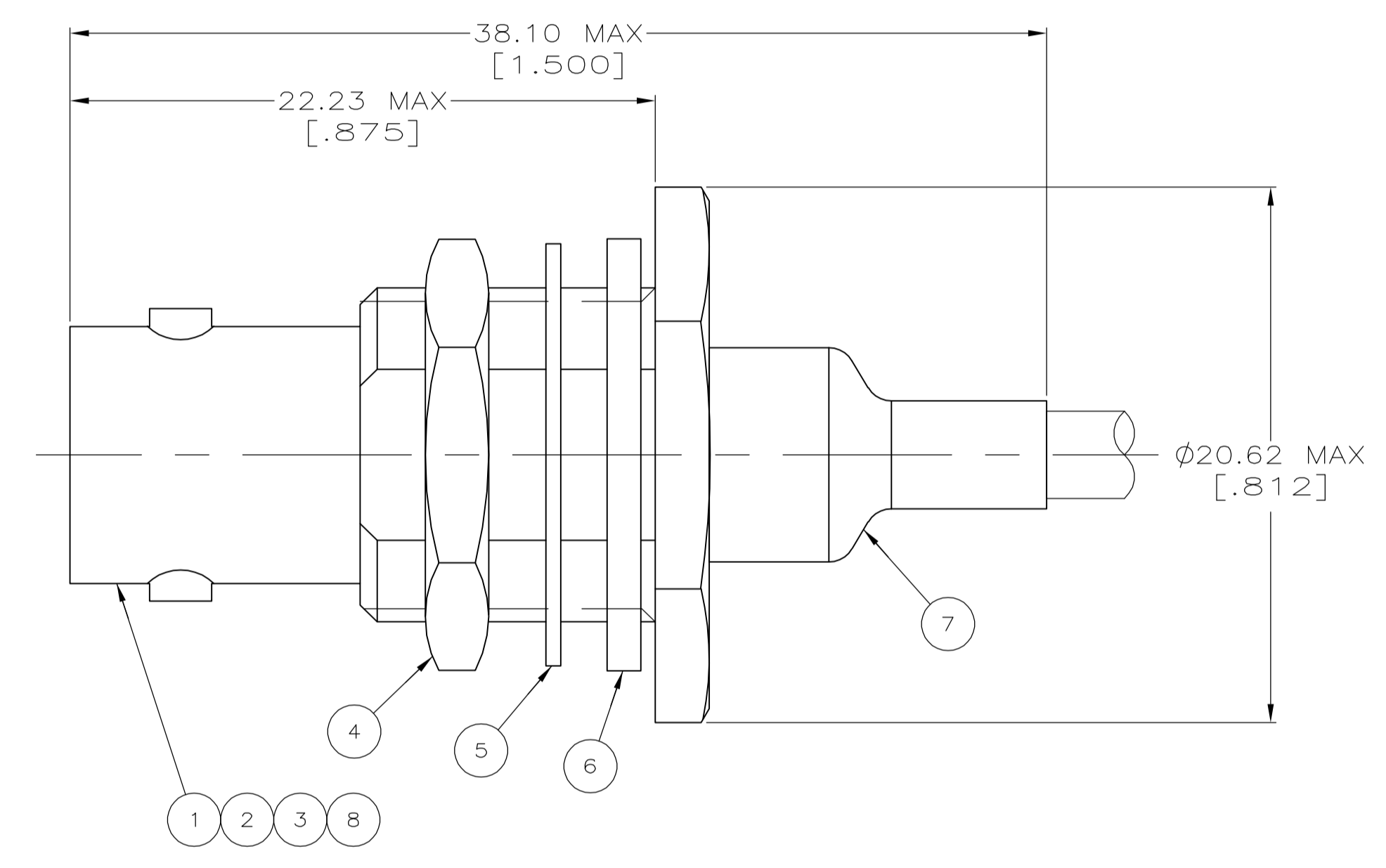
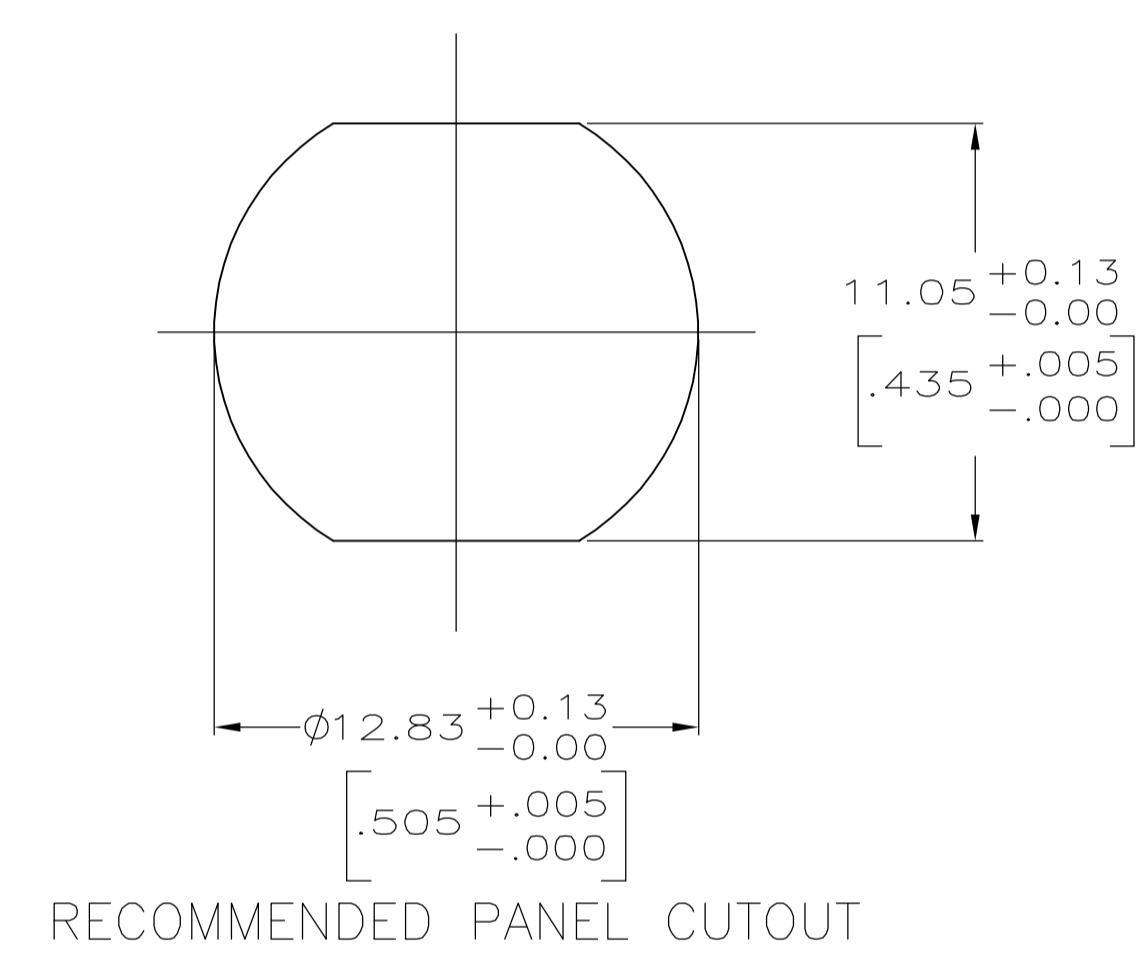

RG-108 & 108A	1	1-332210-0	9-332224-1	329633	9-329632-0	9-329631-0	332214	1-332221-0	9-329791-1	5332342
FOR USE WITH CABLE	CRIMP TOOL	8 DIELECTRIC QTY=1	7 FERRULE QTY=1	6 GASKET QTY=1	5 LOCKWASHER QTY=1	4 JAM NUT QTY=1	3 SEAL QTY=1	2 CRIMP END ASSEMBLY QTY=1	1 BODY, JACK, BULKHEAD QTY=1	PART NUMBER

THIS DRAWING IS A CONTROLLED DOCUMENT.		DWN	L. VARELA - DOCKS	21APR2005	 Tyco Electronics Corporation Harrisburg, PA 17105-3608
DIMENSIONS: mm [INCHES]		CHK	J. HAVENER	21APR2005	
TOLERANCES UNLESS OTHERWISE SPECIFIED:		APVD	J. LIPPERT	21APR2005	NAME
0 PLC	± -	PRODUCT SPEC		JACK, BHD, TWIN BNC	
1 PLC	± -	APPLICATION SPEC		-	
2 PLC	± 0.41 [016]	SIZE		A1	
3 PLC	± -	WEIGHT		00779 C=5332342	
4 PLC	± -	MATERIAL		CUSTOMER DRAWING	
ANGLES	± -	SCALE		5:1	
FINISH	-	SHEET		1 OF 1	
		REV		A	