



**Have a Question?**  
 Chat with a Product  
 Information Specialist

What can we help you find?

[Products](#) | 
 [Industries](#) | 
 [Resources](#) | 
 [About TE](#) | 
 [My Account](#) | 
 [Innovation](#) | 
 [Support Center](#)

## 54010-1 Product Details

[Share](#) | 
 [Print](#) | 
 [Email](#)



**54010-1**

TE Internal Number: 54010-1

Active

View 3D PDF

### CPC Accessories

Always EU RoHS/ELV Compliant (Statement of Compliance)

#### Product Highlights:

- Accessory Type = Cable Seal
- Shell Size = 11
- Cable Diameter Sealing Range = 6.35 - 15.24 mm
- RoHS compliant, ELV compliant
- Lead Free Solder Processes = Not relevant for lead free process

[View all Features](#)

### Quick Links

- ▶ [Pricing & Availability](#)
- ▶ [Search for Tooling](#)
- ▶ [Product Feature Selector](#)
- ▶ [Contact Us About This Product](#)

[Add to My Part List](#) | 
 [Request Sample](#) | 
 [Find Similar Products](#) | 
 [Buy Product](#)

Documentation & Additional Information	
<p><b>Product Drawings:</b></p> <ul style="list-style-type: none"> <li>• <a href="#">STRAIN RELIEF ASSY, SHELL SIZE 11, CPC (PDF, English)</a></li> </ul> <p><b>Catalog Pages/Data Sheets:</b></p> <ul style="list-style-type: none"> <li>• <a href="#">AMP Circular Connectors for Commercial Signal &amp; Powe... (PDF, English)</a></li> </ul> <p><b>Product Specifications:</b></p> <ul style="list-style-type: none"> <li>• None Available</li> </ul> <p><b>Application Specifications:</b></p> <ul style="list-style-type: none"> <li>• None Available</li> </ul> <p><b>Instruction Sheets:</b></p> <ul style="list-style-type: none"> <li>• <a href="#">Accessories for Circular Plastic Connectors (CPC) (PDF, English)</a></li> </ul> <p><b>CAD Files: (CAD Format &amp; Compression Information)</b></p> <ul style="list-style-type: none"> <li>• <a href="#">2D Drawing (DXF, Version AC)</a></li> <li>• <a href="#">3D Model (IGES, Version AC)</a></li> <li>• <a href="#">3D Model (STEP, Version AC)</a></li> </ul>	<p><b>Additional Information:</b></p> <ul style="list-style-type: none"> <li>• <a href="#">Product Line Information</a></li> </ul> <p><b>Related Products:</b></p> <ul style="list-style-type: none"> <li>• <a href="#">Tooling</a></li> </ul>

[List all Documents](#)

Product Features (Please use the Product Drawing for all design activity)	
<p><b>Product Type Features:</b></p> <ul style="list-style-type: none"> <li>• Accessory Type = Cable Seal</li> <li>• Shell Size = 11</li> </ul> <p><b>Dimensions:</b></p> <ul style="list-style-type: none"> <li>• Cable Diameter Sealing Range (mm [in]) = 6.35 - 15.24 [0.250 - 0.600]</li> <li>• Expanded ID, Min. (mm [in]) = 15.90 [0.625]</li> <li>• Recovered ID, Max. (mm [in]) = 6.40 [0.250]</li> </ul> <p><b>Body Features:</b></p> <ul style="list-style-type: none"> <li>• Internal Sleeve Material = Nylon</li> <li>• Internal Sleeve Color = Black</li> <li>• Outer Tubing Material = Polyolefin</li> <li>• Outer Tubing Color = Black</li> </ul>	<p><b>Industry Standards:</b></p> <ul style="list-style-type: none"> <li>• RoHS/ELV Compliance = RoHS compliant, ELV compliant</li> <li>• Lead Free Solder Processes = Not relevant for lead free process</li> <li>• RoHS/ELV Compliance History = Always was RoHS compliant</li> </ul> <p><b>Packaging Features:</b></p> <ul style="list-style-type: none"> <li>• Packaging Quantity = 50</li> </ul> <p><b>Other:</b></p> <ul style="list-style-type: none"> <li>• Brand = AMP</li> </ul>

### Corporate Information

- [About TE](#)
- [Investors](#)
- [News Room](#)
- [Supplier Portal](#)

### Quick Links

- [Distributor Inventory](#)
- [Product Cross Reference](#)
- [Documents & Drawings](#)
- [Product Compliance Support Center](#)

### Customer Support

- [Email or Chat With Us](#)
- [Find a Phone Number](#)
- [Knowledge Base](#)
- [Manage Your Account](#)

THIS DRAWING IS UNPUBLISHED. RELEASED FOR PUBLICATION  
 © COPYRIGHT BY TYCO ELECTRONICS CORPORATION. ALL INTERNATIONAL RIGHTS RESERVED.

LOC	DIST	REVISIONS			
P	LTR	DESCRIPTION	DATE	DWN	APVD
FT	0	AC	REVISED PER ECO-08-028385	25NOV08	HMR BC

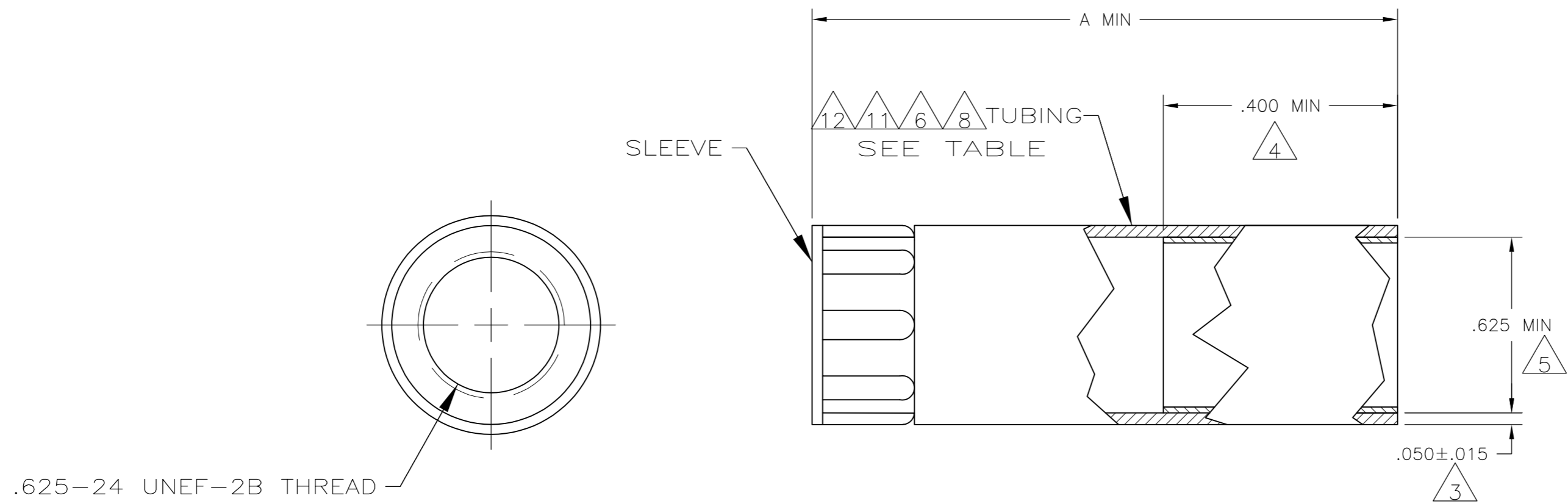

- 1 POLYOLEFIN, BLACK.
- 2 NYLON, BLACK.
- 3 NOMINAL WALL THICKNESS, EXPANDED.
- 4 LENGTH OF SEALANT.
- 5 EXPANDED INSIDE DIAMETER.
- 6 6.35[.250] MAXIMUM RECOVERED INSIDE DIAMETER.
- 7 ASSEMBLY WILL PASS 0.0703 KG PER SQ CENTIMETER [ONE POUND PER SQ IN.] WATER PRESSURE TEST.
- 8 121°C [250°F] SHRINK TEMPERATURE.
- 9 -55°C TO 110°C [-67°F TO 230°F] OPERATING TEMPERATURE.
- 10 THIS PART WILL ACCOMODATE ø6.35 - ø15.24 [ø.250 - ø.600] CABLE RANGE.
- 11 4.06 [.160] MAXIMUM RECOVERED INSIDE DIAMETER.
- 12 ACTUAL SHAPE MAY VARY DUE TO PROCESS VARIANCE.

11	8	2.25	54010-4
6	8	1.25	54010-2
6	8	2.25	54010-1
RECOVERED INSIDE DIA		A	PART NUMBER

THIS DRAWING IS A CONTROLLED DOCUMENT.		DWN C.REIFSNYDER 09 APR 96	Tyco Electronics Corporation Harrisburg, PA 17105-3608	
DIMENSIONS: INCHES		CHK R.STONE 15 APR 95	NAME STRAN RELIEF ASSY, SHELL SIZE 11, CPC	
TOLERANCES UNLESS OTHERWISE SPECIFIED:		APVD T.A.WETZEL 03 MAY 96	SIZE A2	CAGE CODE 00779
0 PLC ± -		PRODUCT SPEC	DRAWING NO C=54010	RESTRICTED TO
1 PLC ± -		APPLICATION SPEC	SCALE 2:1	SHEET 1 of 1
2 PLC ± -		WEIGHT	REV AC	
3 PLC ± -		CUSTOMER DRAWING		
4 PLC ± -				
ANGLES ± -				
FINISH				
MATERIAL TUBING: 11 SLEEVE: 12				