

5414363-3 Product Details

[Share](#) [Print](#) [Email](#)



5414363-3

TE Internal Number: 5414363-3

Active

[View 3D PDF](#)

SMB RF Connectors

Always EU RoHS/ELV Compliant
(Statement of Compliance)

Product Highlights:

- Connector - RF
- Plug
- Standard
- Applies To Coaxial Cable
- Coupler Style = Quick Connect/Disconnect

[View all Features](#)

Quick Links

- ▶ [Pricing & Availability](#)
- ▶ [Search for Tooling](#)
- ▶ [Product Feature Selector](#)
- ▶ [Contact Us About This Product](#)

[Add to My Part List](#) [Request Sample](#) [Find Similar Products](#)

[Buy Product](#)

Documentation & Additional Information

Product Drawings:

- [PLUG,RTANG CRIMP,HEX CRIMP,SMB](#) (PDF, English)

Catalog Pages/Data Sheets:

- [SMB Connectors](#) (PDF, English)

Product Specifications:

- None Available

Application Specifications:

- None Available

Instruction Sheets:

- None Available

CAD Files: (CAD Format & Compression Information)

- [2D Drawing](#) (DXF, Version A)
- [3D Model](#) (IGES, Version A)
- [3D Model](#) (STEP, Version A)

[List all Documents](#)

Related Products:

- [Tooling](#)

Product Features (Please use the Product Drawing for all design activity)

Product Type Features:

- [Product Type](#) = Connector - RF
- [Gender](#) = Plug
- Connector Series = Standard
- [Grade](#) = Consumer
- Dielectric Material = Fluoropolymer

Mechanical Attachment:

- [Panel Mount Retention](#) = Without

Electrical Characteristics:

- [Connector Impedance](#) (Ω) = 50

Termination Features:

- [Coaxial Cable Termination Type](#) = Crimp

Body Features:

- Coupler Style = Quick Connect/Disconnect

Contact Features:

- [Center Contact Plating](#) = Gold over Nickel
- [Outer Contact Plating](#) = Gold over Nickel

Configuration Features:

- [Coaxial Cable Type \(RG/U or Mfg.\)](#) = 174, 188, 316
- [Preloaded](#) = Yes
- [Solder Lug](#) = Without
- [Environmental Protection](#) = Without

Industry Standards:

- [RoHS/ELV Compliance](#) = RoHS compliant, ELV compliant
- [Lead Free Solder Processes](#) = Not relevant for lead free process
- [RoHS/ELV Compliance History](#) = Always was RoHS compliant

- [Body Style](#) = Right Angle
- [Pin Protection](#) = Without
- [Body Plating](#) = Nickel over Copper
- [Body Material](#) = Zinc

Conditions for Usage:

- [Applies To](#) = Coaxial Cable

Other:

- [Brand](#) = AMP

Corporate Information

- [About TE](#)
- [Investors](#)
- [News Room](#)
- [Supplier Portal](#)
- [Careers](#)
- [Terms & Conditions](#)
- [Privacy Policy](#)

Quick Links

- [Distributor Inventory](#)
- [Product Cross Reference](#)
- [Documents & Drawings](#)
- [Product Compliance Support Center](#)
- [Site Map](#)

Customer Support

- [Email or Chat With Us](#)
- [Find a Phone Number](#)
- [Knowledge Base](#)
- [Manage Your Account](#)

Keep Me Informed

THIS DRAWING IS UNPUBLISHED. RELEASED FOR PUBLICATION
 © COPYRIGHT - By - ALL RIGHTS RESERVED.

| LOC | DIST | REVISIONS | | | | | |
|-----|------|-----------|-----|---------------------------|---------|-----|------|
| AJ | 16 | P | LTR | DESCRIPTION | DATE | DWN | APVD |
| | | A1 | | REVISED PER ECO-11-005030 | 11MAR11 | RK | HMR |

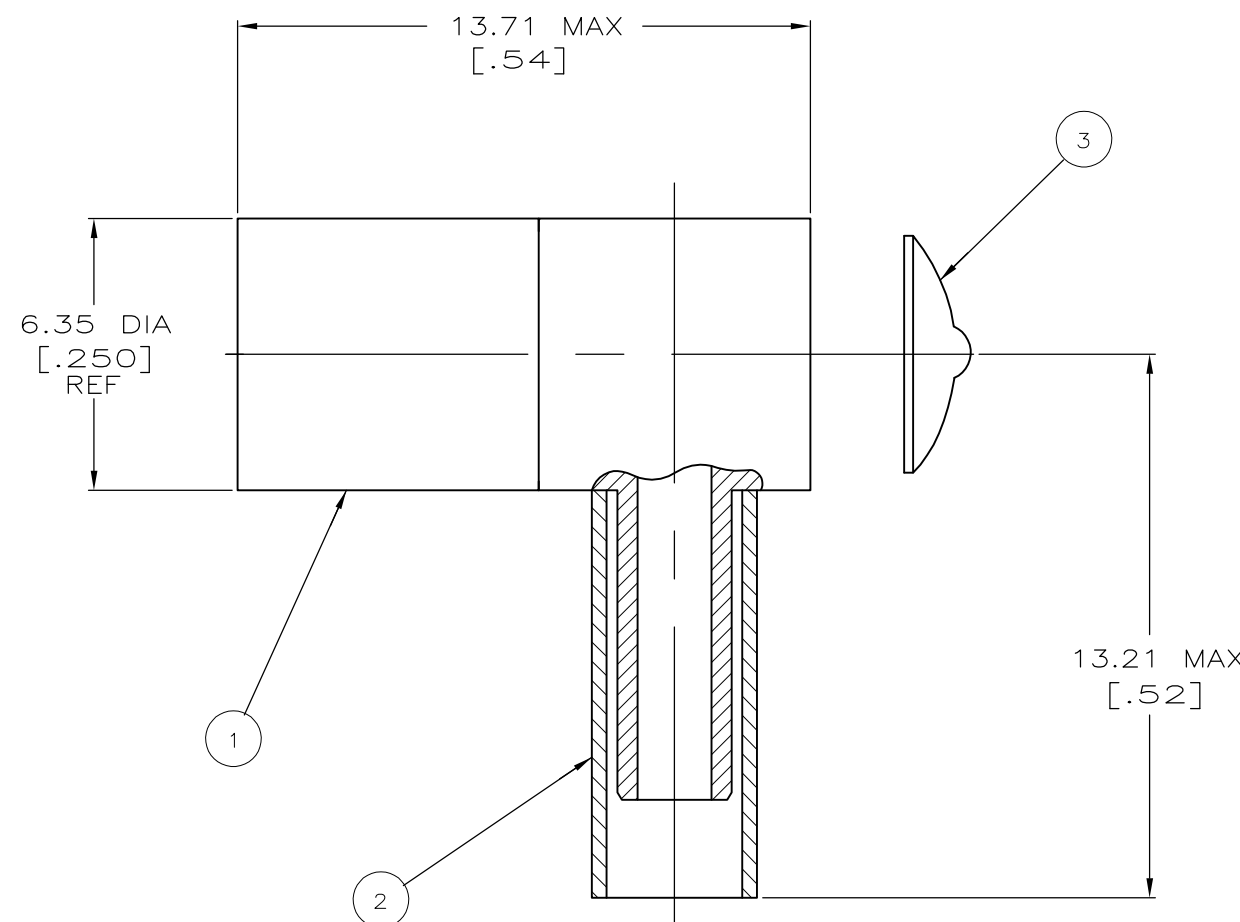

1. INTERFACE PER MIL-C-39012.
2. SEE INSTRUCTION SHEET 408-2987-9.

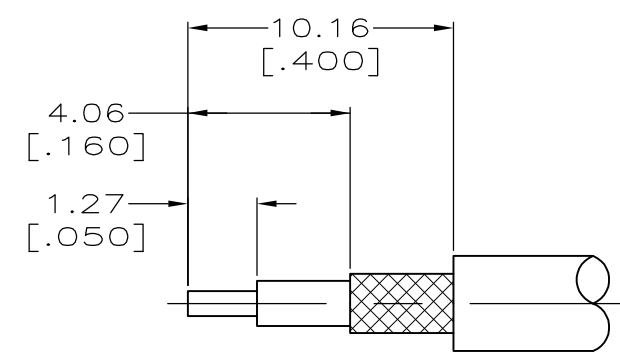

RECOMMENDED STRIP LENGTHS
SCALE NTS

| | | | | | | | | |
|-----------------|-----------------------------|------------------------------|-----------------|-----------------|-----------------|-------------------|----------------------------------|-----------|
| A | 58483-1 | .105 | HX4-1637 | 414013-3 | 1-413889-5 | 9-414364-2 | RG 178,196 | 5414363-8 |
| B | 58483-1 | .128 | HX4-1637 | 414013-3 | 1-413889-3 | 9-414364-1 | RG 174,188,316 | 5414363-5 |
| C | 58483-1 | .151 | HX4-1637 | 414013-3 | 1-413889-4 | 9-414364-0 | RG 174,188,316(ALL DBL SHIELDED) | 5414363-4 |
| B | 58483-1 | .128 | HX4-1637 | 414013-3 | 1-413889-3 | 9-414364-0 | RG 174,188,316 | 5414363-3 |
| POSITION LETTER | AMP DIE SET | HEX SIZE | DANIELS DIE SET | ③ END CAP QTY=1 | ② FERRULE QTY=1 | ① PLUG ASSY QTY=1 | CABLE | PART NO |
| | PRO-CRIMPER FOR BRAID CRIMP | M 22520/5-01 FOR BRAID CRIMP | | | | | | |

| | | | | | | | | |
|-------------------------|--|---|--|---------------------------|---|--|--|--|
| TOOLING INFORMATION | | THIS DRAWING IS A CONTROLLED DOCUMENT. | | DWN J. HAVENER 23MAR2005 | TE Connectivity | | | |
| | | | | CHK J. HAVENER 23MAR2005 | | | | |
| DIMENSIONS: mm [INCHES] | | TOLERANCES UNLESS OTHERWISE SPECIFIED: | | APVD J. HAVENER 23MAR2005 | SIZE CAGE CODE DRAWING NO RESTRICTED TO A3 00779 C-5414363 | | | |
| | | 0 PLC ± - 1 PLC ± - 2 PLC ± 0.25 [.010] 3 PLC ± 0.130 [.005] 4 PLC ± - ANGLES ± 1° | | PRODUCT SPEC - | | | | |
| MATERIAL - | | FINISH - | | APPLICATION SPEC - | | | | |
| | | | | WEIGHT - | CUSTOMER DRAWING | | | |