

Distributed by:

JAMECO[®]
ELECTRONICS

www.Jameco.com ♦ 1-800-831-4242

The content and copyrights of the attached
material are the property of its owner.

Jameco Part Number 1932782

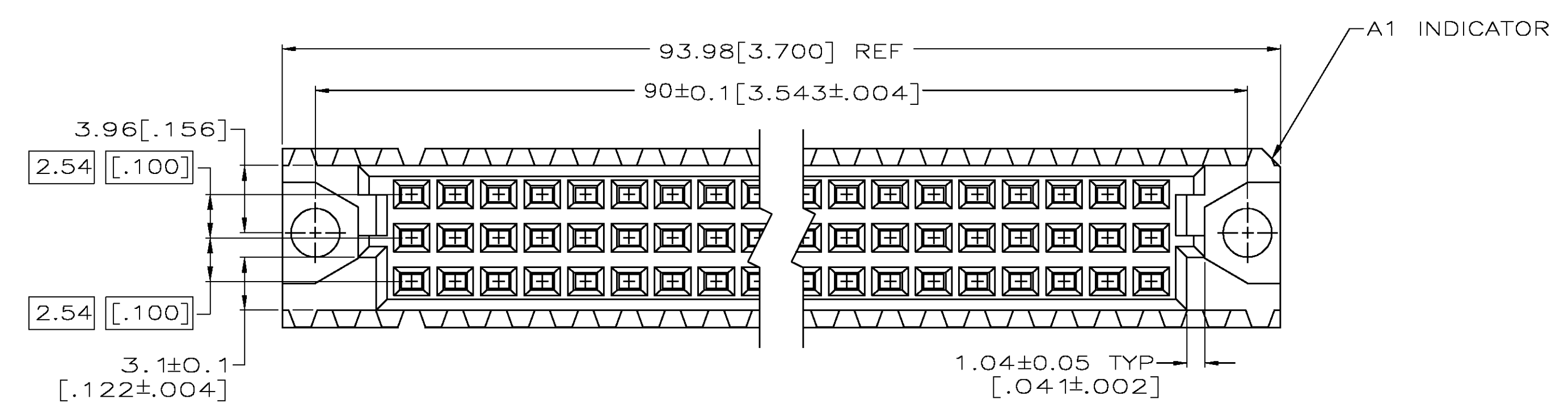

- △ HOUSING MATERIAL: GLASS-FILLED POLYMER. COLOR: GRAY.
- △ CONTACT MATERIAL: COPPER ALLOY.
- △ CONTACT FINISH: DIN 41612 CLASS 2 IN CONTACT AREA. TIN PLATE ON POSTS.
- △ CONTACT FINISH: DIN 41612 CLASS 3 IN CONTACT AREA. TIN PLATE ON POSTS.
- △ PART NUMBER, DATE CODE IDENTIFICATION, CSA LOGO IN THIS APPROXIMATE AREA.
- △ POINT OF MEASUREMENT FOR FINISH.
- △ ACTION PIN POSTS REQUIRE 1.57 [.062] MINIMUM THICK PC BOARD. RECOMMENDED PC BOARD HOLES ARE $\phi .151 \pm 0.2$ [.0453 ± .001] DRILLED HOLE WITH 0.02-0.07 [.001-.003] COPPER AND 0.008 [.0003] MINIMUM TIN-LEAD PLATING. FINISHED HOLE AFTER PLATING, $\phi 0.94-1.09$ [.037-.043].

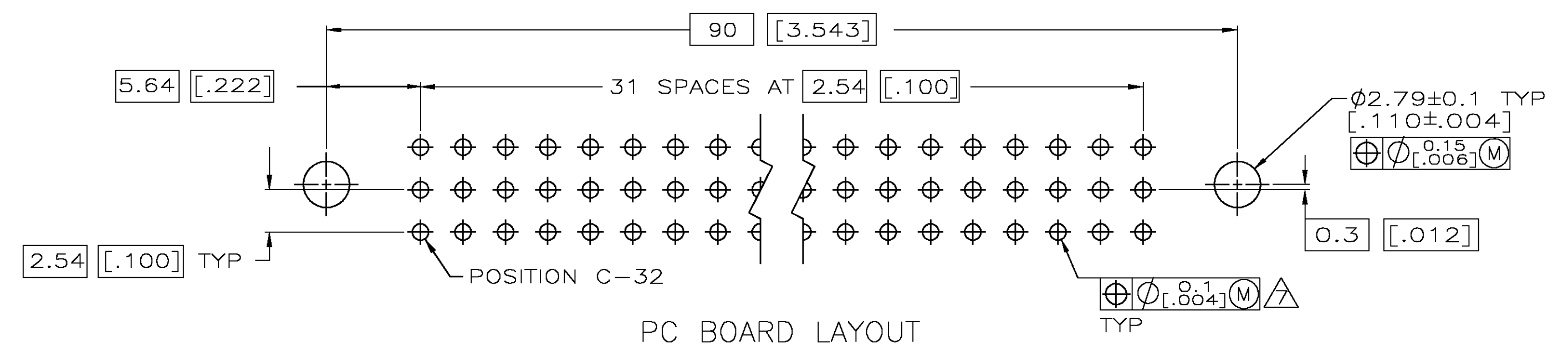
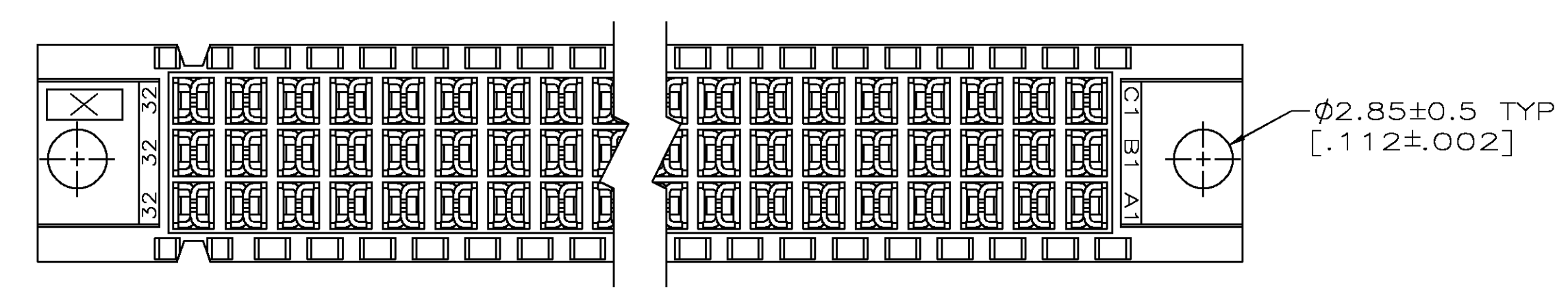
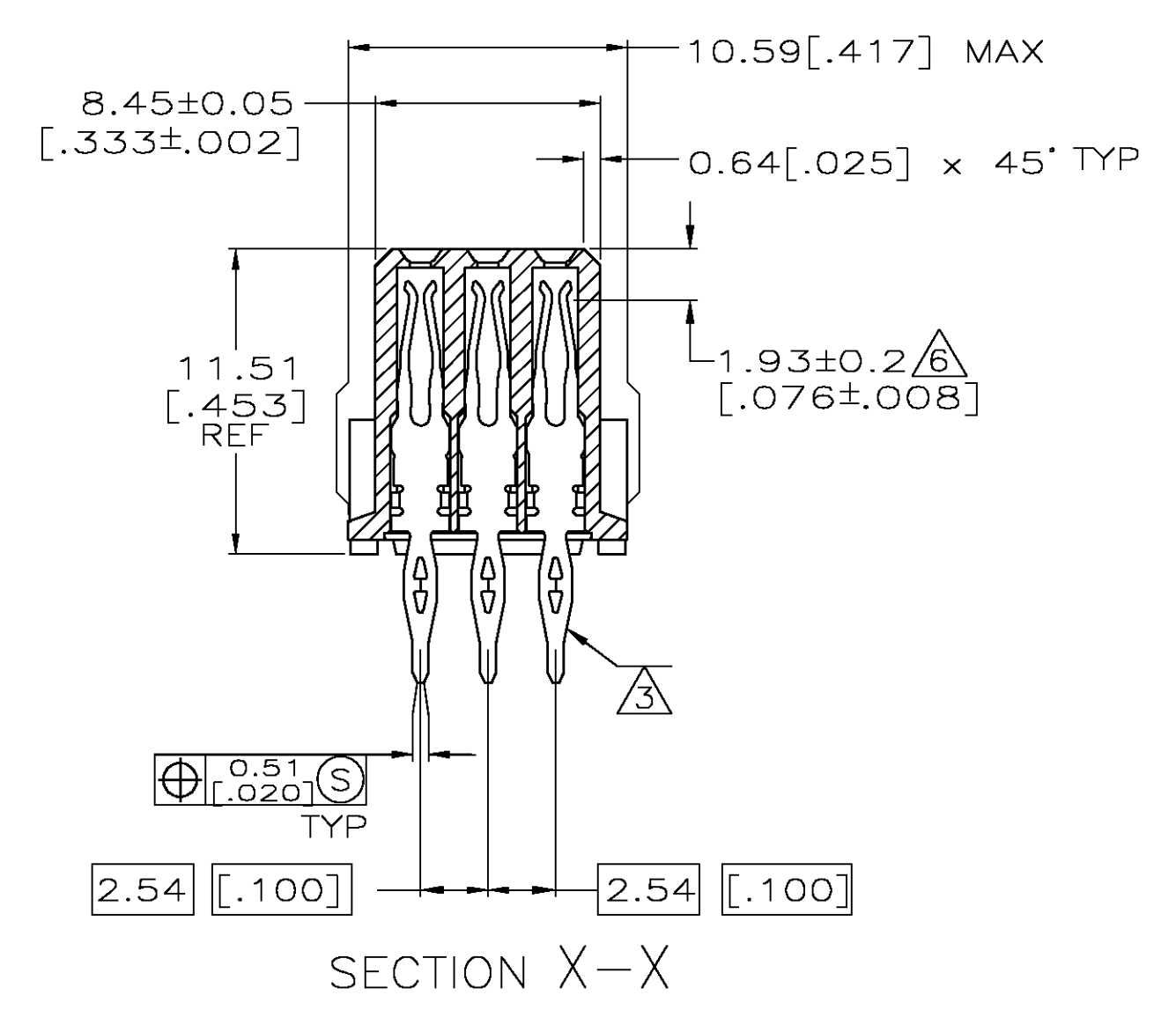
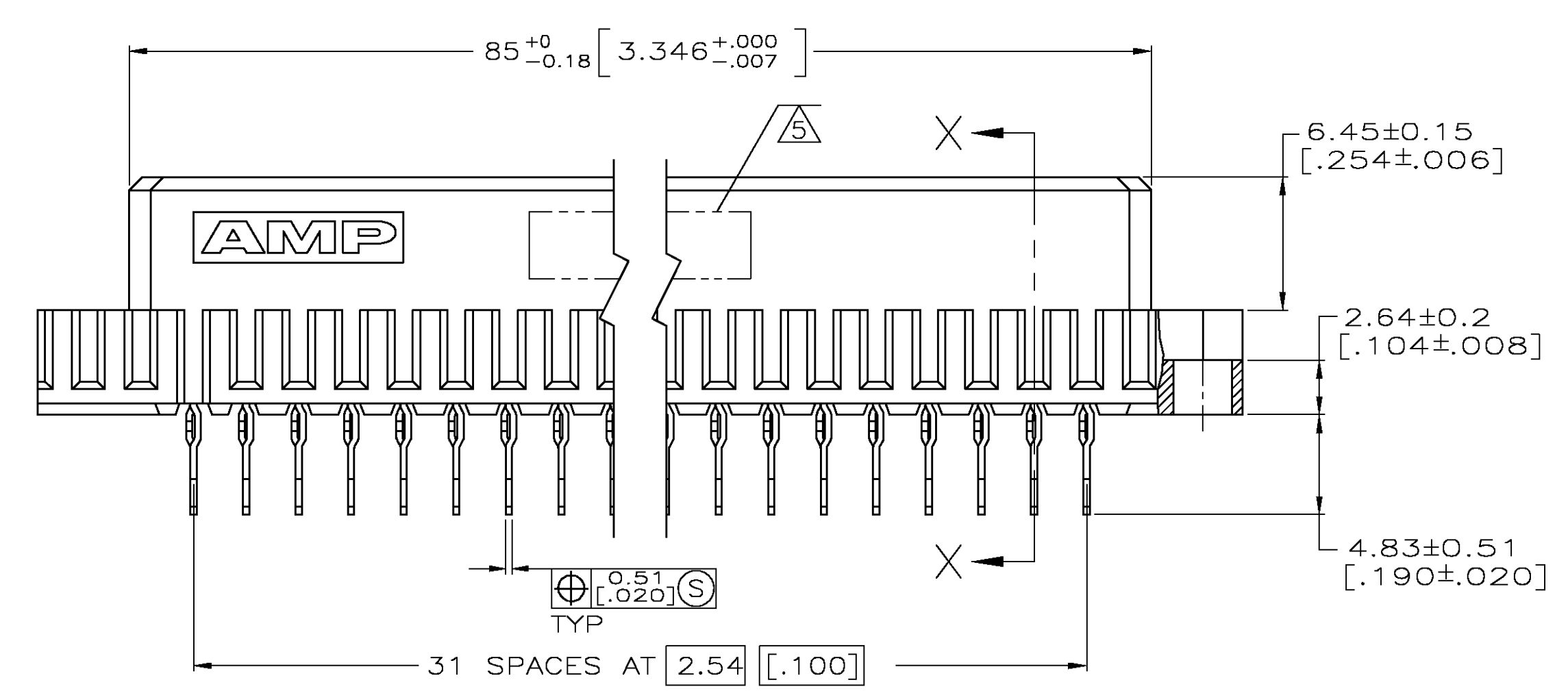

FINISH	POSITIONS LOADED	ROWS LOADED			NO. OF LOADED POSITION	ASSY PART NUMBER
		C	B	A		
△ 4	1 THRU 32	X	X	X	96	5535032-9
△ 3	1 THRU 32	X	X	X	96	5535032-5
△ 3	1 THRU 32	X	X	X	96	5535032-4

THIS DRAWING IS A CONTROLLED DOCUMENT. DRN: J. POLIGNONE 25MAY05
 CHK: A. SHARPE 25MAY05
 APD: A. SHARPE 25MAY05

Tyco Electronics
 Tyco Electronics Corporation
 Harrisburg, Pa 17105-3608

NAME: ASSEMBLY, RECEPTACLE, EUROCARD, TYPE C, LEAD-FREE, 96 POSITION, 4.83 [.190] TOOLES, PRESS-FIT

SIZE: A1 CAGE CODE: 00779 DRAWING NO: 5535032 RESTRICTED TO: -

MATERIAL: △ 1/2 △ 3/4 WEIGHT: - SCALE: 4:1 SHEET: 1 OF 1 REV: 0