

- 1 HOUSING MATERIAL: GLASS-FILLED POLYMER.
- 2 CONTACT MATERIAL: COPPER ALLOY.
- 3 CONTACT FINISH: DIN 41612 CLASS 2 IN CONTACT AREA. TIN PLATE ON POSTS.
- 4 CONTACT POINT.
- 5 RECOMMENDED HOLE SIZE FOR MANUAL APPLICATION OF CONNECTOR ONTO PC BOARD.
- 6 PART NUMBER, DATE CODE IDENTIFICATION, CSA LOGO IN THIS APPROXIMATE AREA, ON REVERSE SIDE.

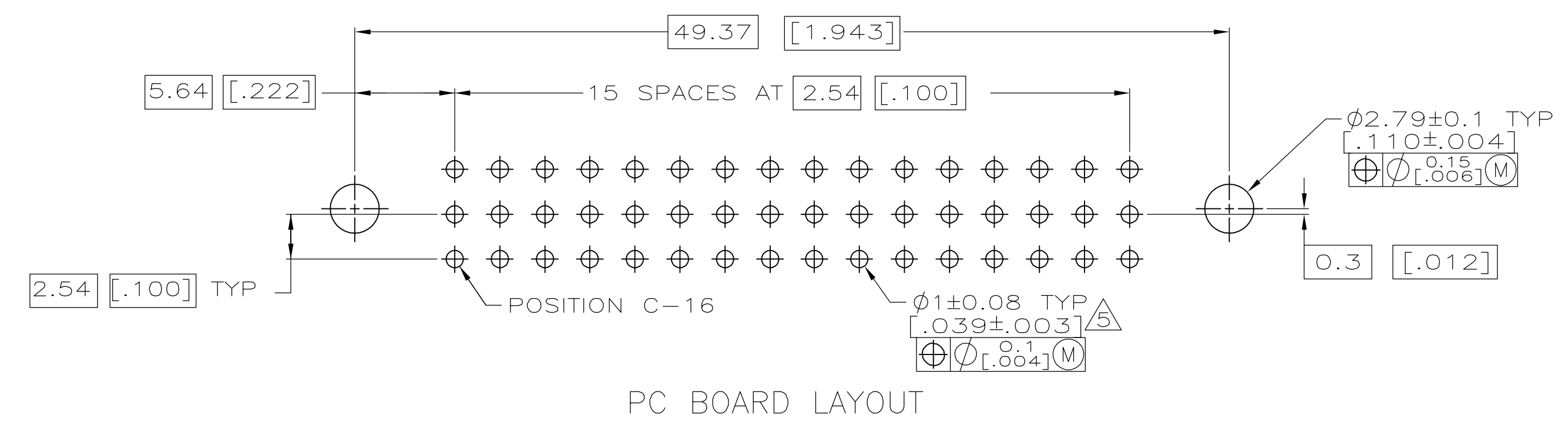
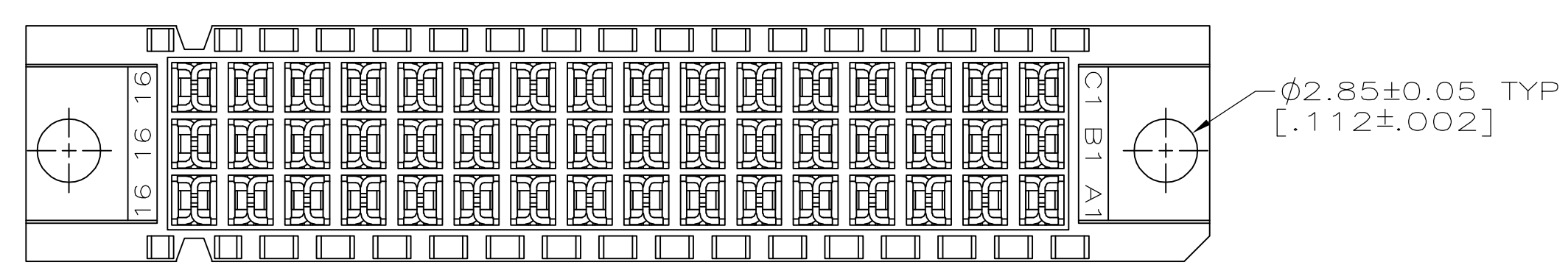
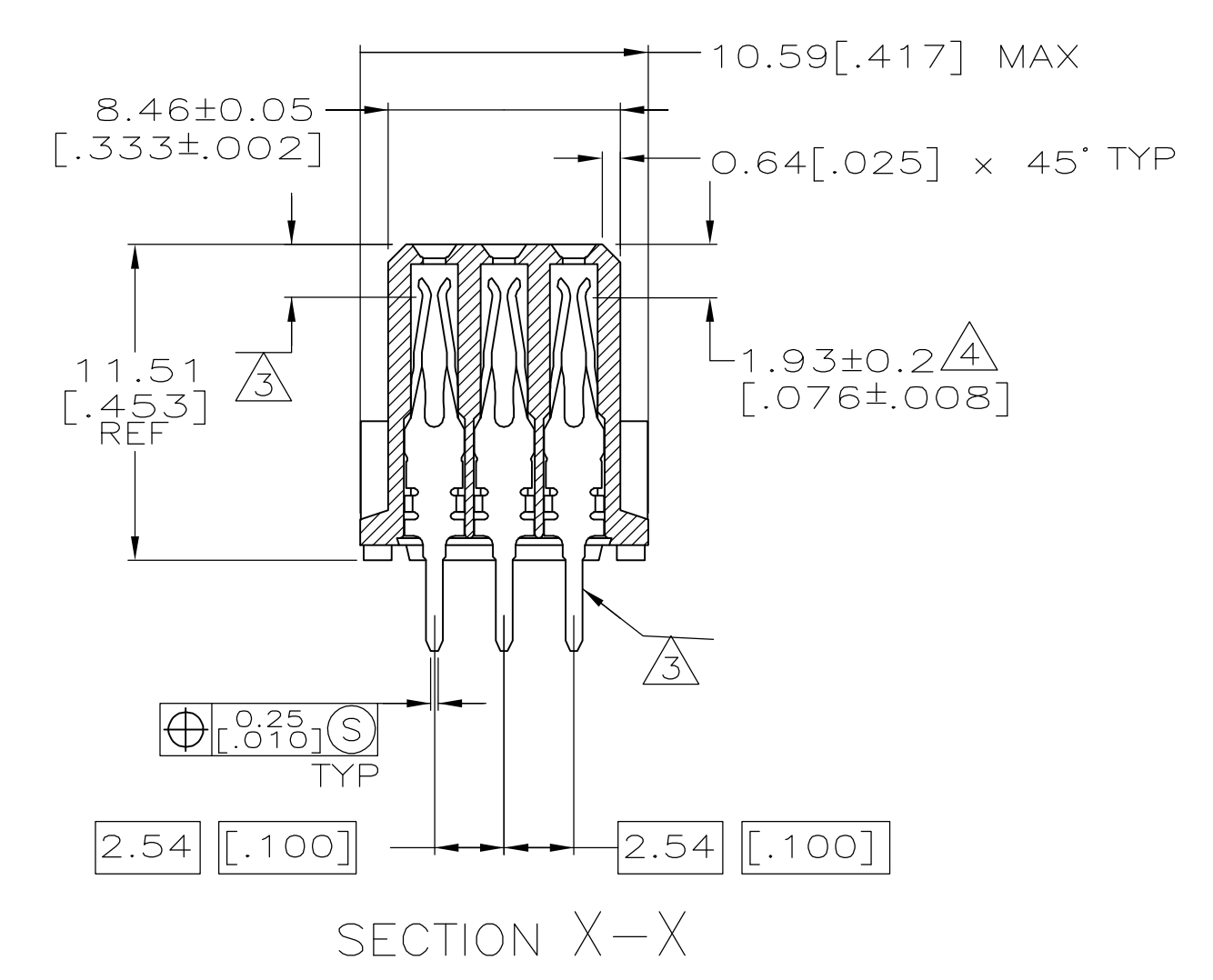
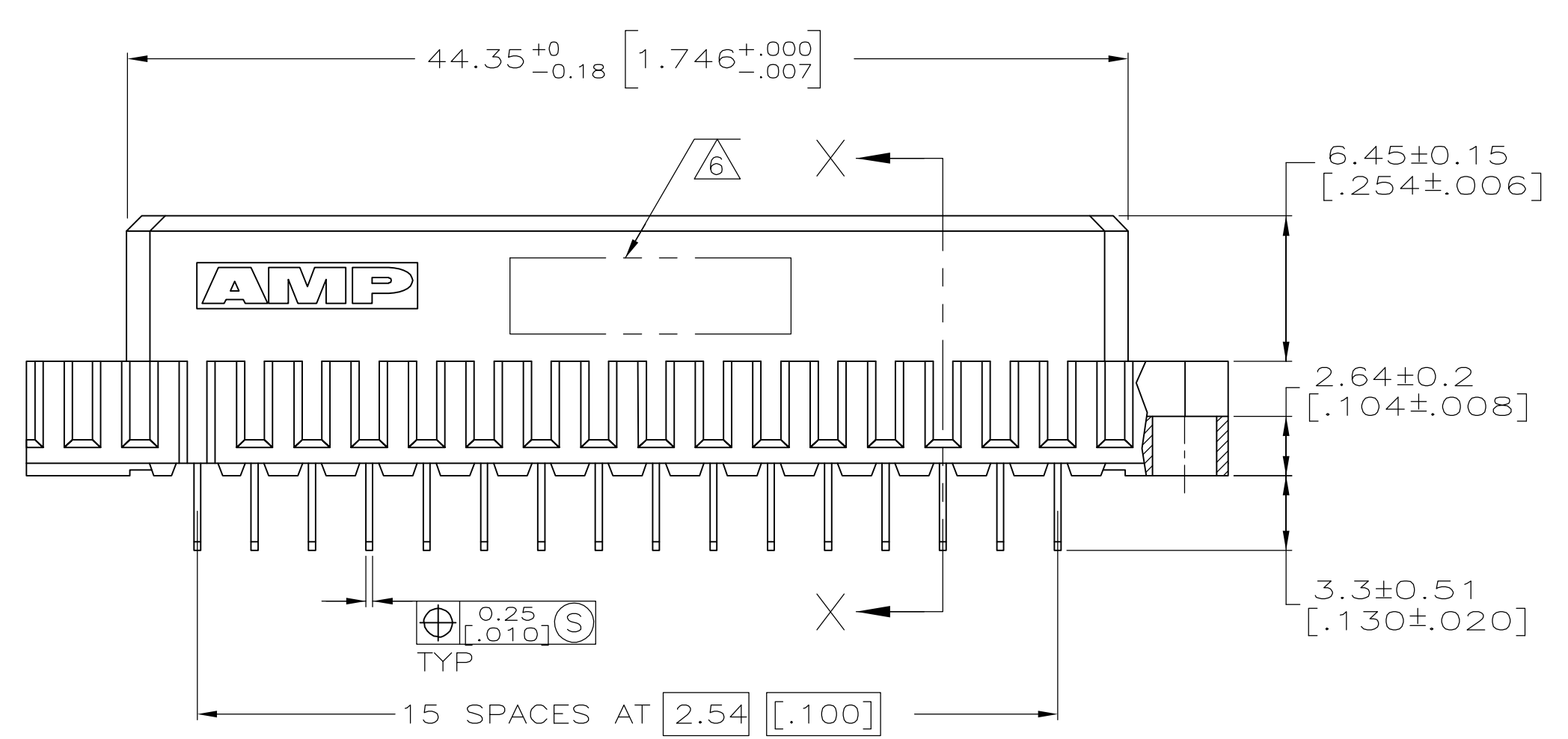
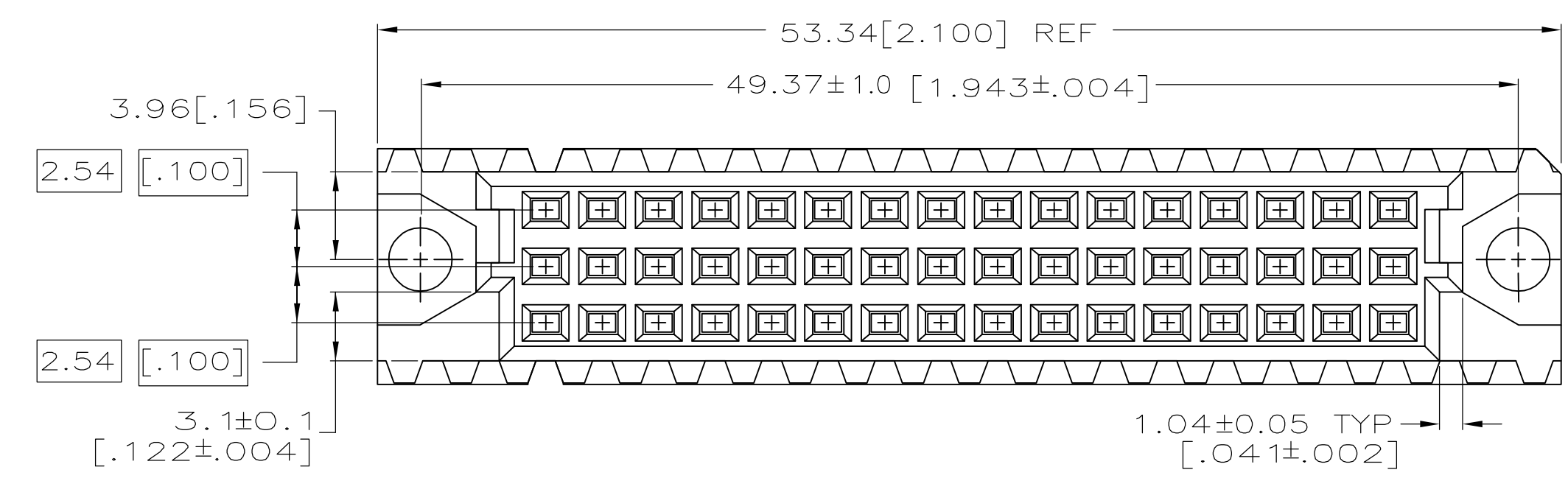

1 THRU 16	X	X	X	48	5535070-5
1 THRU 16	X	X	X	48	5535070-4
POSITIONS LOADED	C	B	A	NO. OF LOADED POSITIONS	PART NUMBER

THIS DRAWING IS A CONTROLLED DOCUMENT.		DWN	J. POLIGNONE	27MAY05	 Tyco Electronics Corporation Harrisburg, Pa 17105-3608
DIMENSIONS: mm [INCHES]		CHK	A. SHARPE	27MAY05	
TOLERANCES UNLESS OTHERWISE SPECIFIED:		APP'D	A. SHARPE	27MAY05	NAME
0 PLC	± -	PRODUCT SPEC		ASSEMBLY, RECEPTACLE, EUROCARD, 1/2C, LEAD-FREE, 48 POSITION, 3.30 [0.130] SOLDER POSTS	
1 PLC	± -	APPLICATION SPEC		SIZE	A1
2 PLC	± 0.15 [0.005]	MATERIAL		CAGE CODE	00779
3 PLC	± -	FINISH		DRAWING NO	5535070
4 PLC	± -	RESTRICTED TO		WEIGHT	-
ANGLES	± -	CUSTOMER DRAWING		SCALE	4:1
		SHEET		1	OF 1
		REV		0	