

- ① HOUSING MATERIAL: LIQUID CRYSTAL POLYMER PER ASTM D5138 LCP000 G30A 32250, COLOR: NATURAL.
- ② CONTACT MATERIAL: PHOSPHOR-BRONZE.
- ③ CONTACT FINISH:
 UNDERPLATE (ENTIRE CONTACT) -
 0.00127 MIN NICKEL PER SAE-AMS-QQ-N-290.
 ON MATING SURFACES-
 CONFORMS TO ALL TESTING SPECIFIED FOR TELCORDIA UNCONTROLLED ENVIRONMENT
 ON LEADS-
 0.0006 MIN TIN PER ASTM B 545, OVER UNDERPLATE
 LUBRICATION (MIN MATING SURFACES)
 SURFACE CONDITIONER AFTER PLATING.
- ④ PART MARKING, LOCATED APPROXIMATELY AS SHOWN.
- ⑤ CONTACT FINISH:
 UNDERPLATE (ENTIRE CONTACT) -
 0.00127 MIN NICKEL PER SAE-AMS-QQ-N-290.
 ON MATING SURFACES-
 0.00076 MIN NICKEL OR COBALT HARDENED GOLD PER ASTM B-488 OVER UNDERPLATE.
 ON LEADS-
 0.0006 MIN TIN PER ASTM B 545, OVER UNDERPLATE
 LUBRICATION (MIN MATING SURFACES)
 SURFACE CONDITIONER AFTER PLATING.

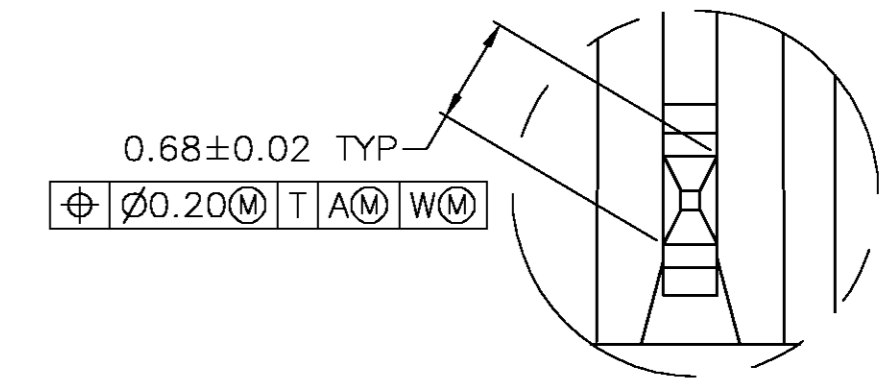

DETAIL Z
SCALE 20:1

	NO	46	23	47.88	⑤	96	3-5536511-3
	NO	22	11	23.88	⑤	48	3-5536511-2
	YES	10	5	11.88	⑤	24	3-5536511-1
	NO	34	17	35.88	③	72	1-5536511-2
	NO	130	65	131.88	③	264	1-5536511-1
OBSOLETE	NO	106	53	107.88	③	216	1-5536511-0
	NO	118	59	119.88	③	240	5536511-9
	NO	82	41	83.88	③	168	5536511-8
OBSOLETE	NO	66	33	67.88	③	136	5536511-7
	NO	58	29	59.88	③	120	5536511-6
	NO	70	35	71.88	③	144	5536511-5
	NO	94	47	95.88	③	192	5536511-4
	NO	46	23	47.88	③	96	5536511-3
	NO	22	11	23.88	③	48	5536511-2
	YES	10	5	11.88	③	24	5536511-1
POSITIONING PEGS	C	B	A	FINISH	NO OF POSN	PART NUMBER	

RECOMMENDED CIRCUIT PATTERN
 PER IPC-D300 TYPE II, CLASS C
 (COMPONENT SIDE)

THIS DRAWING IS A CONTROLLED DOCUMENT.

DRN: B MCMMASTER 31AUG04
 QIK: R WERTZ 31AUG04
 NAME: R WERTZ 31AUG04

Tyco Electronics Corporation
 Harrisburg, Pa 17105-3608

RCPT. ASSY, SIGNAL MODULE, Z-PACK 2mm FB
 4 ROW, 3.55mm PRESS FIT LEAD LENGTH

SIZE: A1 CAGE CODE: 00779 DRAWING NO: 5536511
 WEIGHT: -

CUSTOMER DRAWING SCALE: 4:1 SHEET: 1 OF 1 REV: B