

DETAIL Z
SCALE 20:1

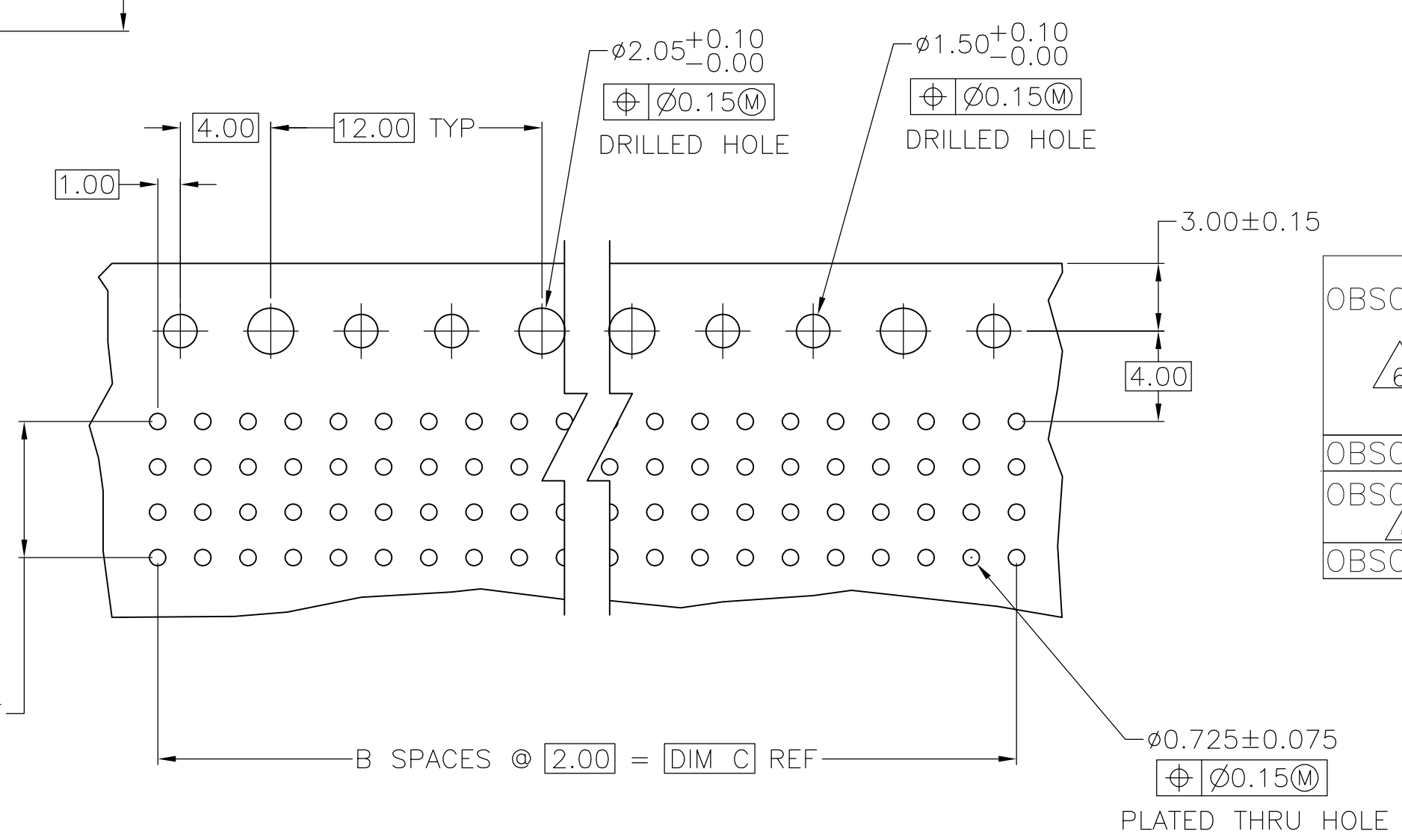

RECOMMENDED CIRCUIT PATTERN
PER IPC-D300 TYPE II, CLASS C
(COMPONENT SIDE)

- △ HOUSING MATERIAL: LIQUID CRYSTAL POLYMER PER ASTM D5138 LCP000 G30A 32250, COLOR: NATURAL.
- △ CONTACT MATERIAL: PHOSPHOR-BRONZE.
- △ CONTACT FINISH:
UNDERPLATE (ENTIRE CONTACT) -
0.00127 MIN NICKEL PER SAE-AMS-QQ-N-290.
ON MATING SURFACES-
CONFORMS TO ALL TESTING SPECIFIED FOR TELCORDIA UNCONTROLLED ENVIRONMENT
ON LEADS-
0.0006 MIN TIN PER ASTM B 545, OVER UNDERPLATE
LUBRICATION (MIN MATING SURFACES)
SURFACE CONDITIONER AFTER PLATING.
- △ PART MARKING, LOCATED APPROXIMATELY AS SHOWN.
- △ CONTACT FINISH:
UNDERPLATE (ENTIRE CONTACT) -
0.00127 MIN NICKEL PER SAE-AMS-QQ-N-290.
ON MATING SURFACES-
0.00076 MIN NICKEL OR COBALT HARDENED GOLD PER ASTM B-488 OVER UNDERPLATE.
ON LEADS-
0.0006 MIN TIN PER ASTM B 545, OVER UNDERPLATE
LUBRICATION (MIN MATING SURFACES)
SURFACE CONDITIONER AFTER PLATING.
- △ OBSOLETE PARTS: OBSOLETE CIS STREAMLINING PER D.RENAUD/D.SINISI

OBsolete	NO	46	23	47.88	△ 5	96	-3=5536511-3-
	NO	22	11	23.88	△ 5	48	-3=5536511-2-
	YES	10	5	11.88	△ 5	24	-3=5536511-1-
	NO	34	17	35.88	△ 3	72	-1=5536511-2-
	NO	130	65	131.88	△ 3	264	-1=5536511-1-
OBsolete	NO	106	53	107.88	△ 3	216	-1=5536511-0-
OBsolete	NO	118	59	119.88	△ 3	240	-5536511-9-
	NO	82	41	83.88	△ 3	168	-5536511-8-
OBsolete	NO	66	33	67.88	△ 3	136	-5536511-7-
	NO	58	29	59.88	△ 3	120	5536511-6
	NO	70	35	71.88	△ 3	144	5536511-5
	NO	94	47	95.88	△ 3	192	5536511-4
	NO	46	23	47.88	△ 3	96	5536511-3
	NO	22	11	23.88	△ 3	48	5536511-2
	YES	10	5	11.88	△ 3	24	5536511-1
POSITIONING PEGS	C	B	A	FINISH	NO OF POSN	PART NUMBER	

THIS DRAWING IS A CONTROLLED DOCUMENT. DIM B, MCMASER 31AUG04. DIM R, WERTZ 31AUG04.

DIMENSIONS: mm. TOLERANCES UNLESS OTHERWISE SPECIFIED:

0 PL	±	-
1 PL	±	-
2 PL	±	.13
3 PL	±	.13
4 PL	±	-
ANGLES	±	°

MATERIAL: △ 1 △ 2. FINISH: △ 3 △ 5.

STE TE Connectivity

RCPT. ASSY, SIGNAL MODULE, Z-PACK 2mm FB
4 ROW, 3.55mm PRESS FIT LEAD LENGTH

SIZE: A1. CAGE CODE: 00779. DRAWING NO: 5536511. WEIGHT: -. RESTRICTED TO: -. SCALE: 4:1. SHEET: 1 of 1. REV: B3.