

LOC		DIST		ZONE		LTR		REVISIONS		DATE	APPD
AD	47	P	F					K	REVISE PER ECN 001B-0210-00	27NOV00	SU/DK

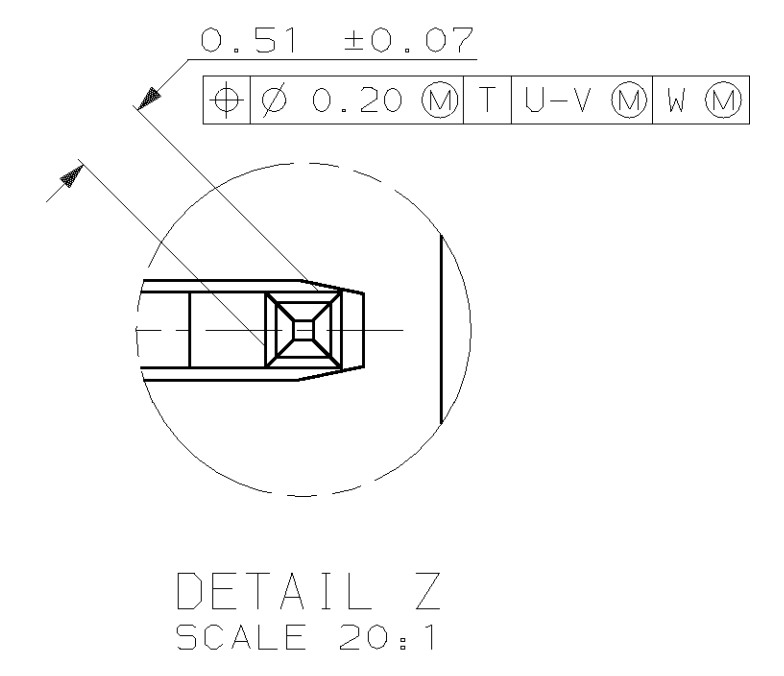
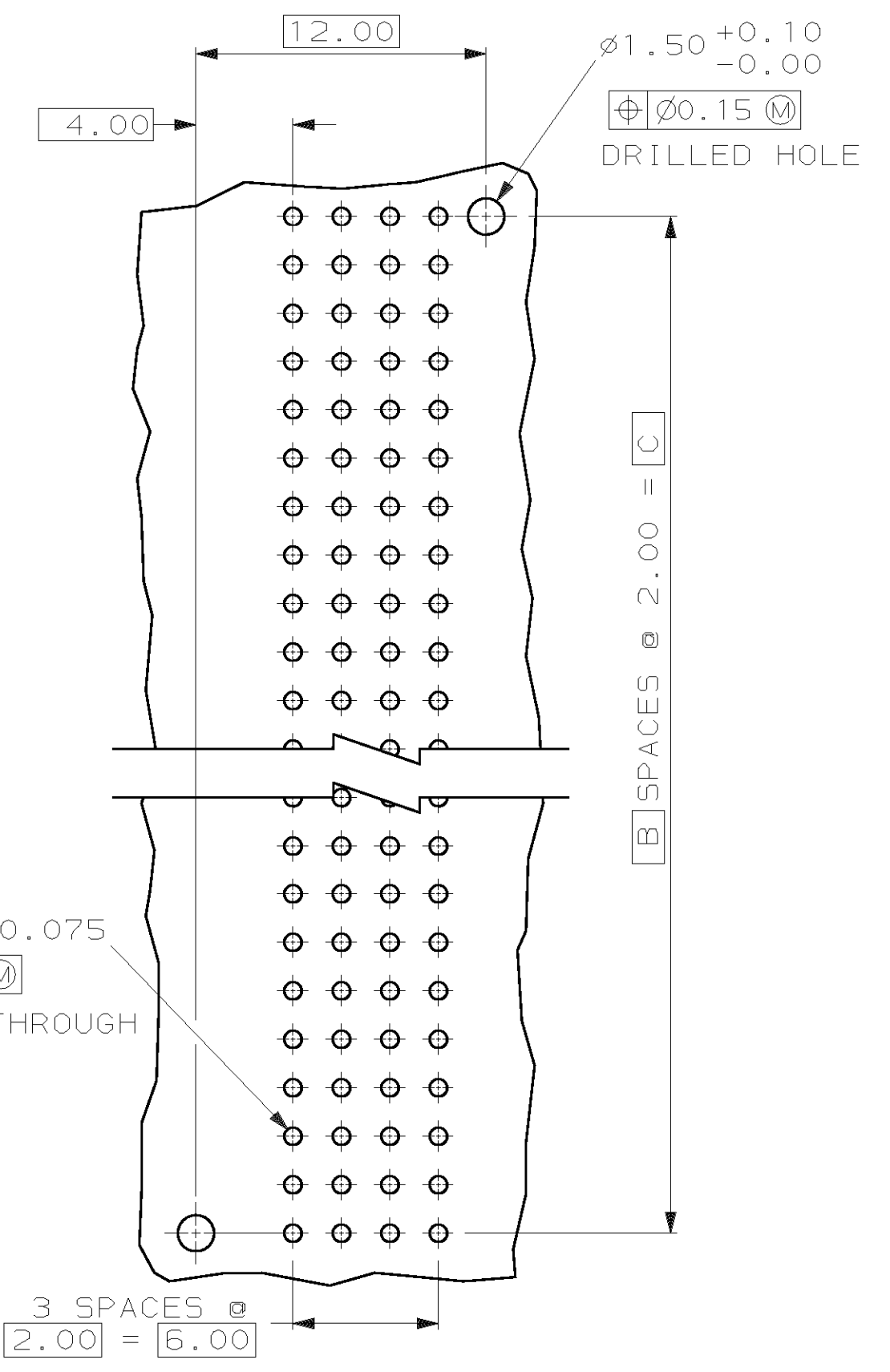
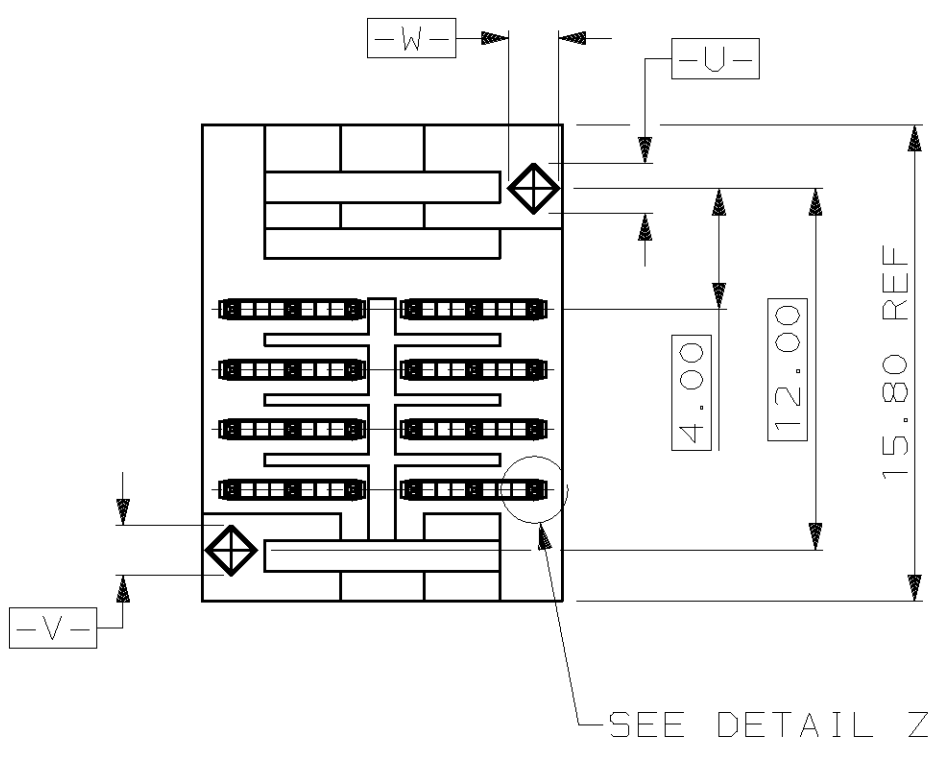
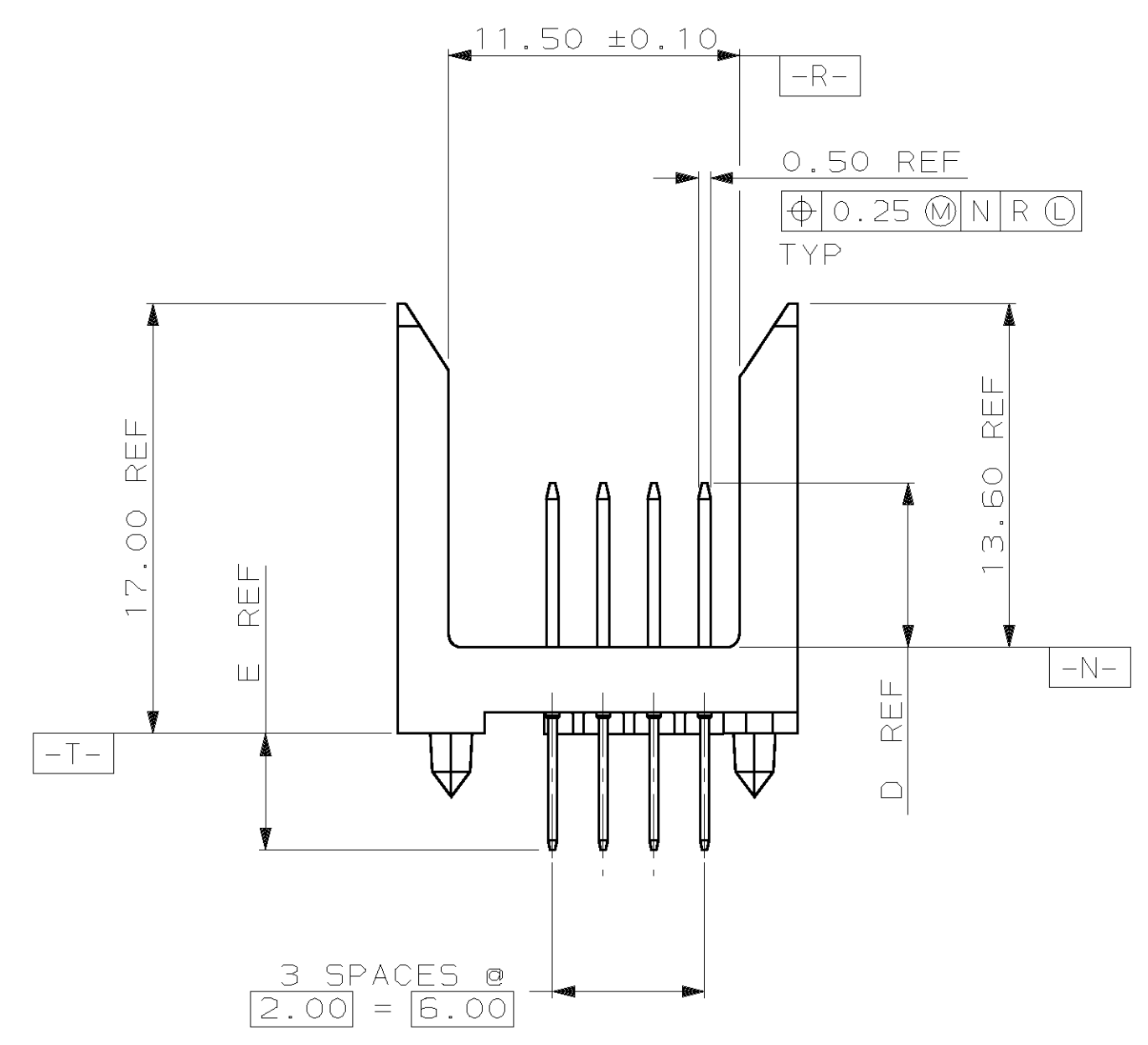
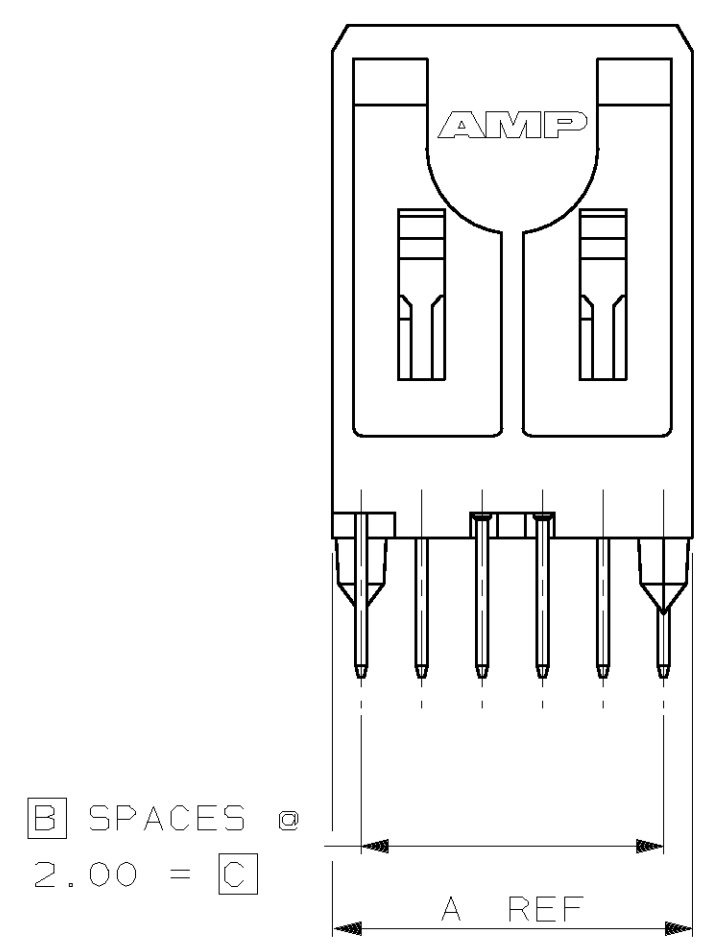
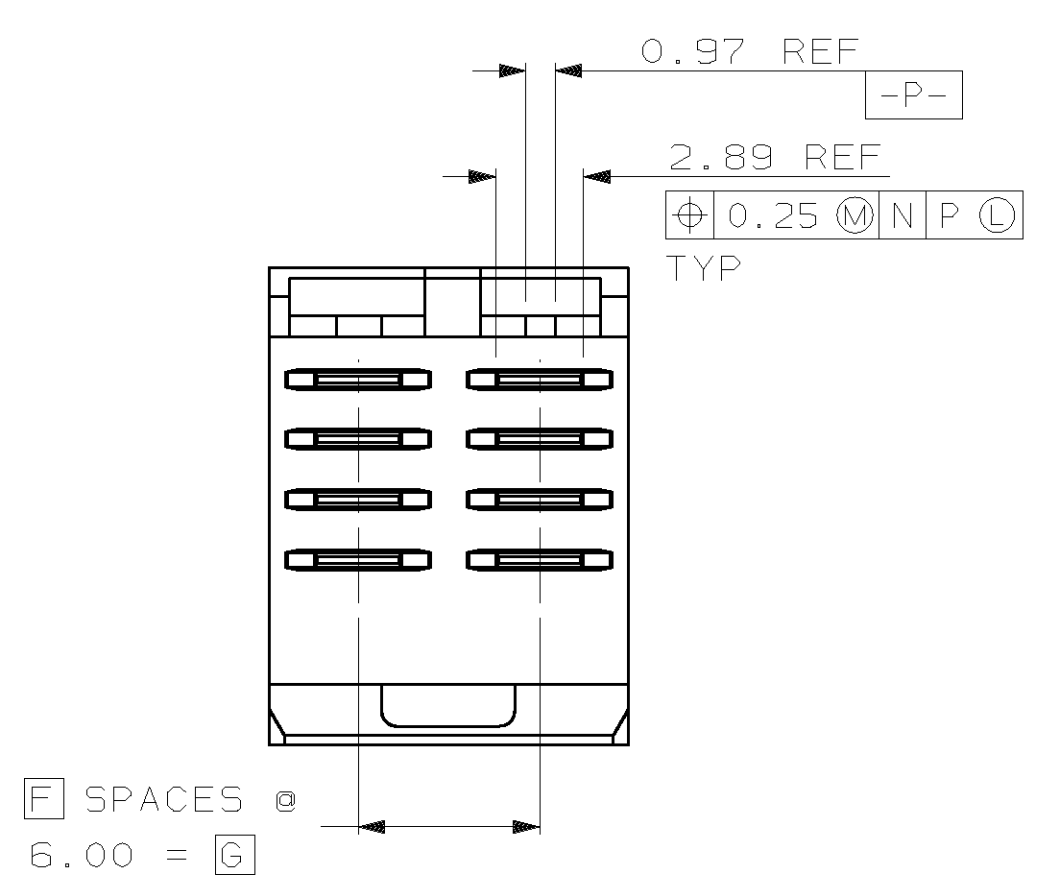

- 1 HOUSING MATERIAL: LIQUID CRYSTAL POLYMER PER ASTM D5138 LCPO00 G30A 32250.
- 2 CONTACT MATERIAL: PHOSPHOR BRONZE PER UNS ALLOY NO. C51100, TEMPER: H04.
- 3 CONTACT FINISH:
ON MATING SURFACES-
FLASH GOLD PER AMP INCORPORATED SPECIFICATION, OVER
0.0008 MIN. PALLADIUM-NICKEL PER AMP INCORPORATED SPECIFICATION, OVER
0.0013 MIN. NICKEL
ON LEADS-
0.004 MIN. TIN-LEAD, OVER
0.0013 MIN. NICKEL
SURFACE CONDITIONER PER AMP SPECIFICATION 112-1002(ENTIRE CONTACT AFTER PLATING).
- 4 PART MARKING PER AMP INCORPORATED SPECIFICATION 115-9009,
LOCATED APPROXIMATELY AS SHOWN.
- 5 CONTACT FINISH:
UNDERPLATE (ENTIRE CONTACT):
0.0013 MIN NICKEL.
ON MATING SURFACES:
SURFACE CONDITIONER OVER, 0.0008 NICKEL OR COBALT
HARDENED GOLD PER AMP SPECIFICATION, OVER UNDERPLATE.
ON LEADS:
SURFACE CONDITIONER OVER, 0.004 MIN TIN-LEAD,
OVER UNDERPLATE.

6.00	1	4.25	6.50	10.00	5	11.83	5	8	536600-1
G	F	E	D	C	B	A	FINISH	NO OF POSN	PART NUMBER

DO NOT SCALE PRINT. UNLESS SPECIFIED DIMENSIONS IN MILLIMETERS TOLERANCES ON: 2 PLC DEC ± 0.13 3 PLC DEC ± - ANGLES ± -		DR 08/11/92 D.R.BENDER CHK 09/03/92 R.L.BENDORF APPD 09/03/92 D.R.BAECHTLE APPD 09/03/92 C.W.LINDGREN	AMP AMP Incorporated Harrisburg, PA 17105-3608	
MATERIAL	FINISH	PRODUCT SPEC	NAME Z-PACK 2mm FB, POWER MODULE, PIN ASSEMBLY 2mm ϕ , 4 ROW, TABLED MATING & LEAD LENGTHS	
		APPLICATION SPEC	SIZE D	CAGE CODE 00779
		WEIGHT	DRAWING NO G-536600	SHEET 1 OF 1

METRIC

THIS DRAWING IS A CONTROLLED DOCUMENT FOR AMP INCORPORATED. IT IS SUBJECT TO CHANGE AND THE CONTROLLING ENGINEERING ORGANIZATION SHOULD BE CONTACTED FOR THE LATEST REVISION.