

THIS DRAWING IS UNPUBLISHED. RELEASED FOR PUBLICATION
 © COPYRIGHT BY TYCO ELECTRONICS CORPORATION. ALL RIGHTS RESERVED.

LOC	DIST	REVISIONS					
GP	00	P	LTR	DESCRIPTION	DATE	DWN	APVD
			0	RELEASED PER EC OS13-0288-05	03OCT05	BM	WM

1. ALL DIMENSIONS SHOWN ARE FOR REFERENCE ONLY.
 2. 2 REQUIRED OF EACH COMPONENT PER KIT.
- 3 MATERIAL:
 STANDOFF: BLACK ZINC PLATED CARBON STEEL.
 NUT, FLAT WASHER & LOCKWASHER: ZINC PLATED CARBON STEEL.

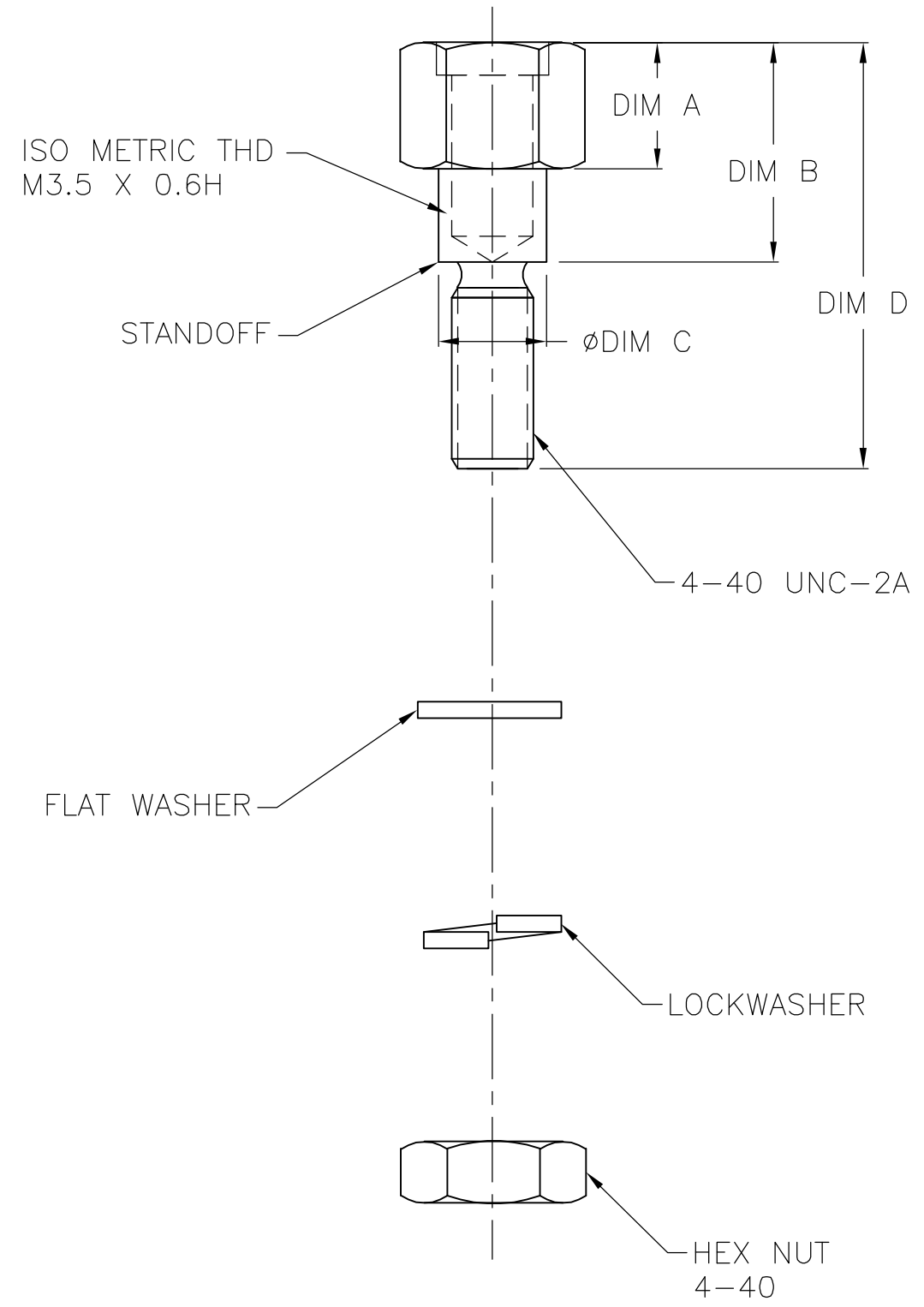

16.51[.650]	4.7[.185]	8.5[.335]	4.9[.193]	5552633-4
16.51[.650]	4.2[.165]	8.6[.339]	6.5[.256]	5552633-3
DIM D	DIM C	DIM B	DIM A	PART NUMBER

THIS DRAWING IS A CONTROLLED DOCUMENT.		DWN	B. MCMASTER	03OCT05	tyco Electronics	Tyco Electronics Corporation	
DIMENSIONS: mm [INCHES]		CHK	W. MILLHIMES	03OCT05		Harrisburg, PA 17105-3608	
TOLERANCES UNLESS OTHERWISE SPECIFIED:		APVD	W. MILLHIMES	03OCT05	NAME		
0 PLC ± -		PRODUCT SPEC	HARDWARE KIT, STANDOFF, STUD MOUNT, METRIC				
1 PLC ± -		APPLICATION SPEC	SIZE				
2 PLC ± -		WEIGHT	A3 00779 C-5552633				
3 PLC ± -		CUSTOMER DRAWING		SCALE	4:1	SHEET	1 of 1
4 PLC ± -				REV	0		
ANGLES ± -							
FINISH							
3							