

LOC		DIST		REVISIONS			
P	LTR	DESCRIPTION	DATE	DWN	APVD		
B		ECO-07-019679	30AUG07	LAM	PR		

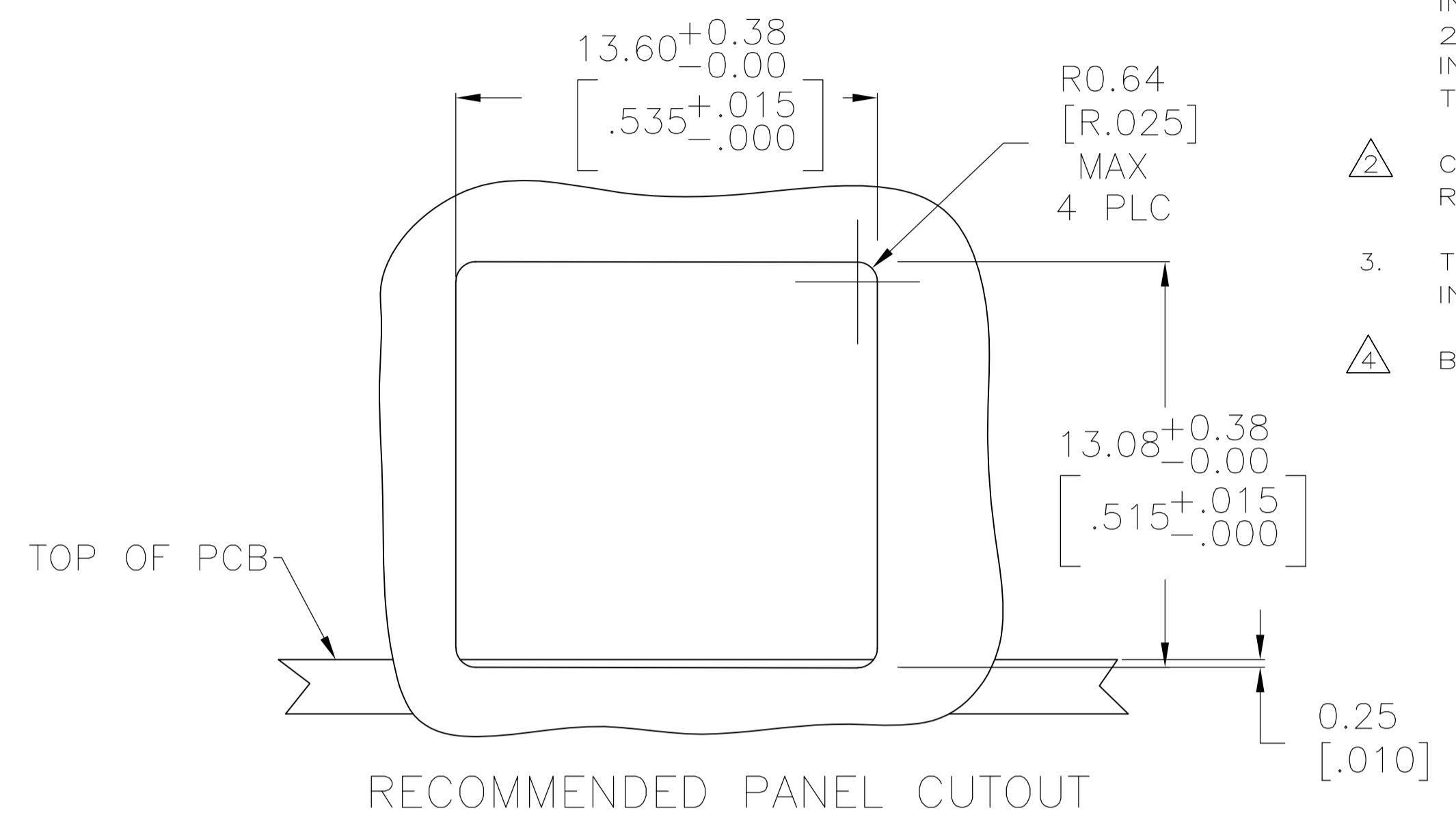

- MATERIAL: HOUSING - PBT POLYESTER, BLACK.  
 TERMINAL - 0.35 [.0138] THICK PHOSPHOR BRONZE PLATED WITH 1.27µm [.000050] THICK HARD GOLD IN LOCALIZED GOLD PLATE AREA AND 2.03µm [.000080] THICK MATTE TIN IN SOLDER AREA OVER 1.27µm [.000050] THICK NICKEL UNDERPLATE.
- CAVITY CONFORMS TO FCC RULES AND REGULATIONS PART 68, SUBPART F.
- TERMINALS FOR 5555163-2 AND -5 LOCATED IN CENTER POSITIONS.
- BULK PACKAGED IN A TRAY.

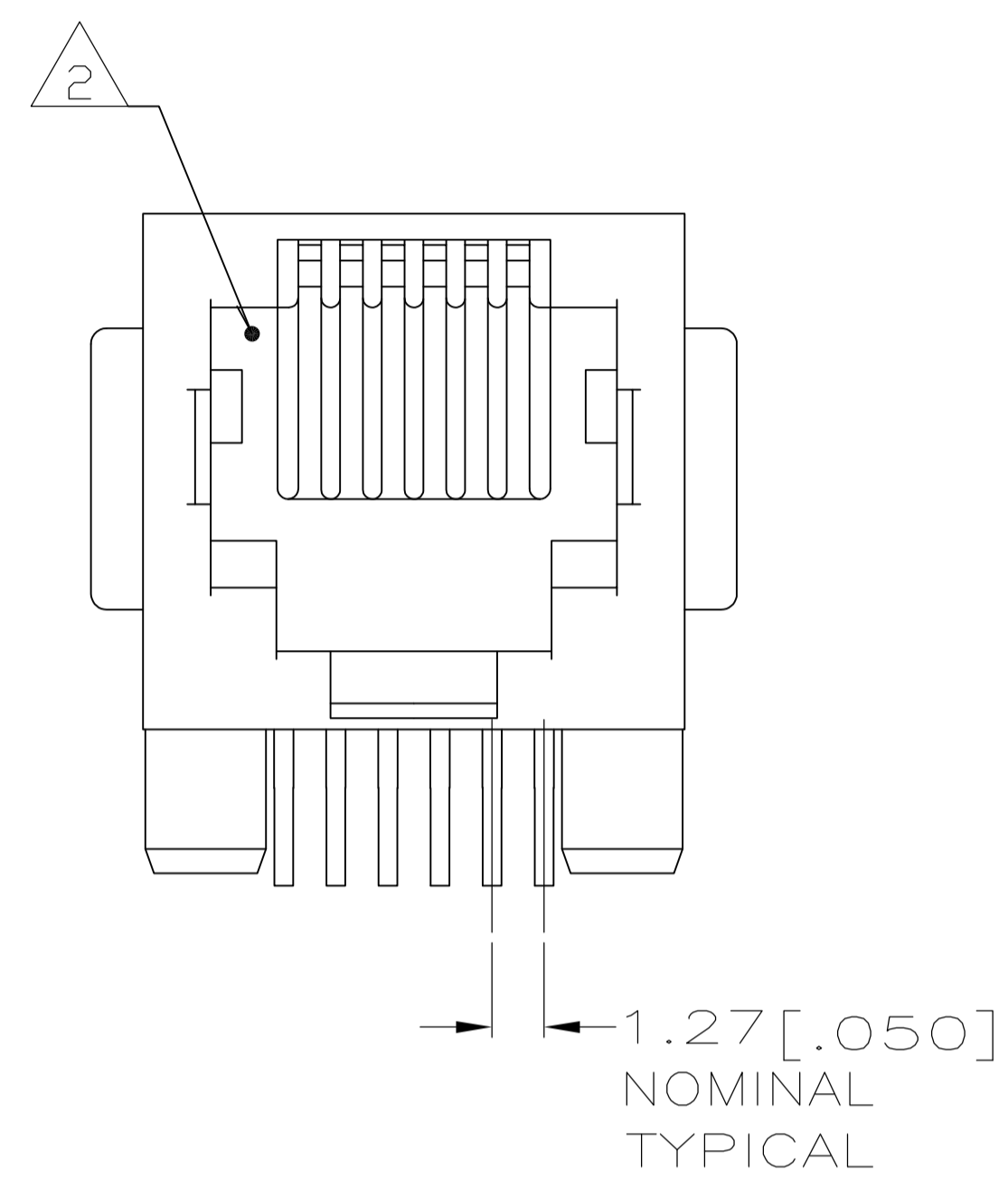
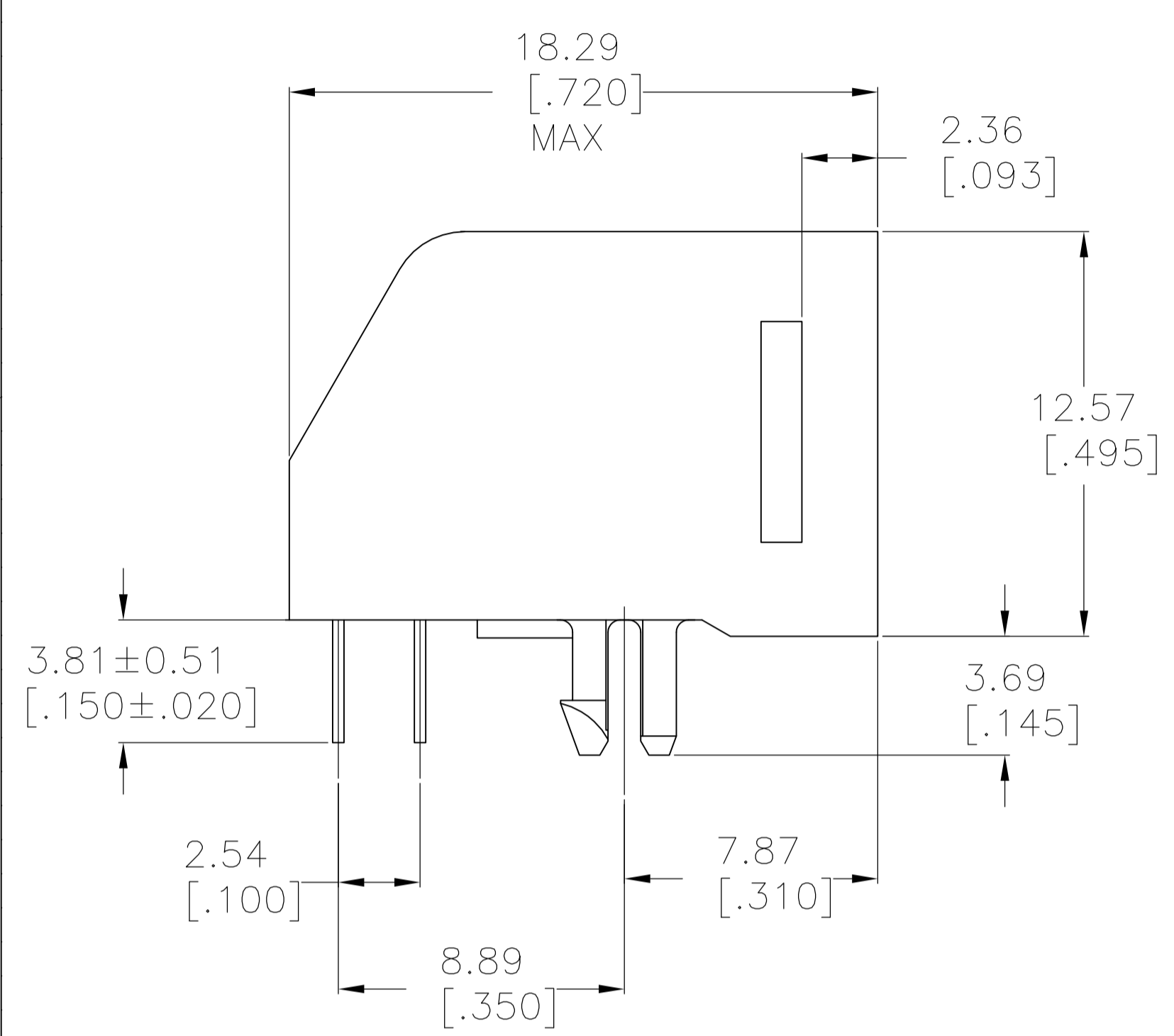
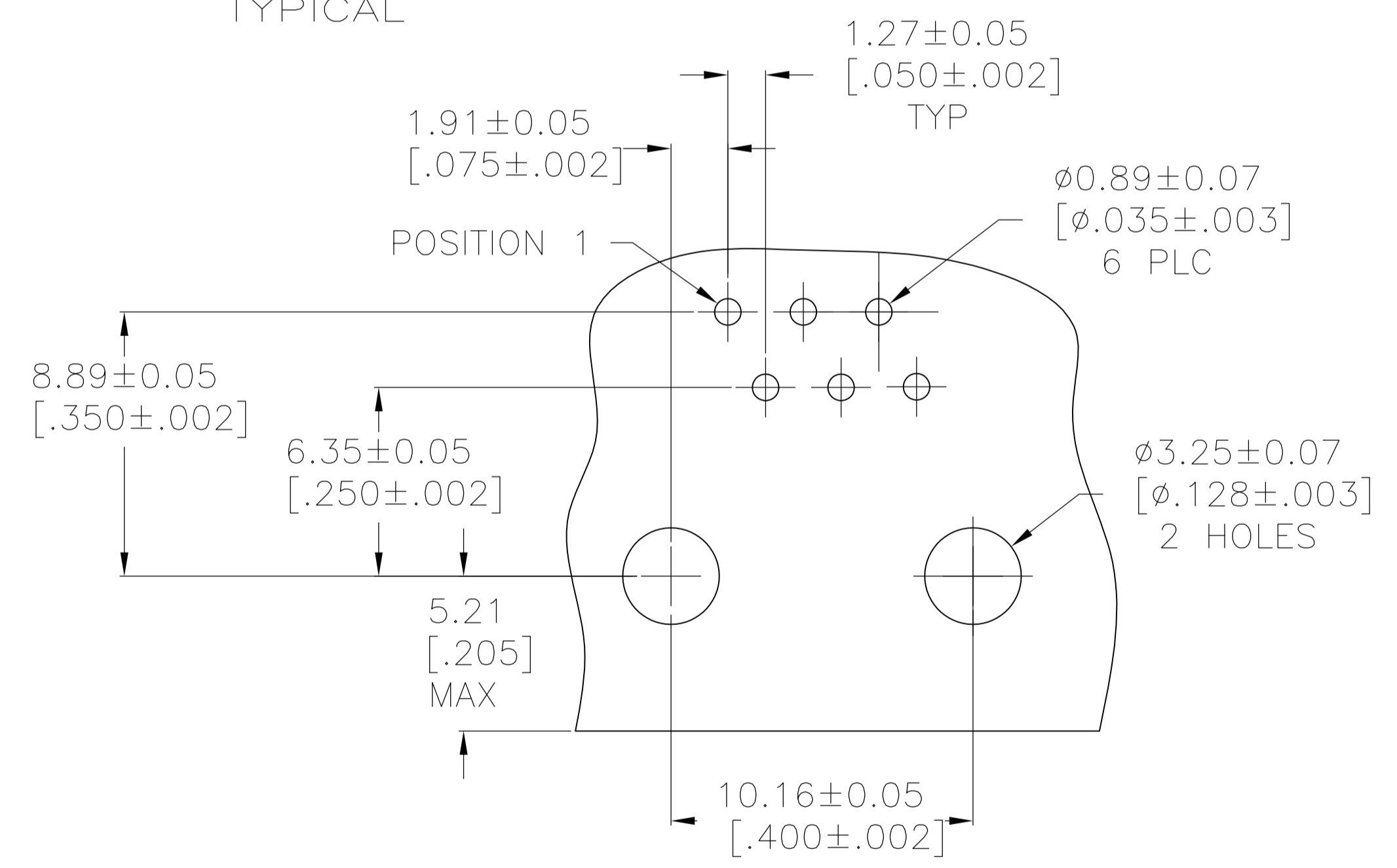
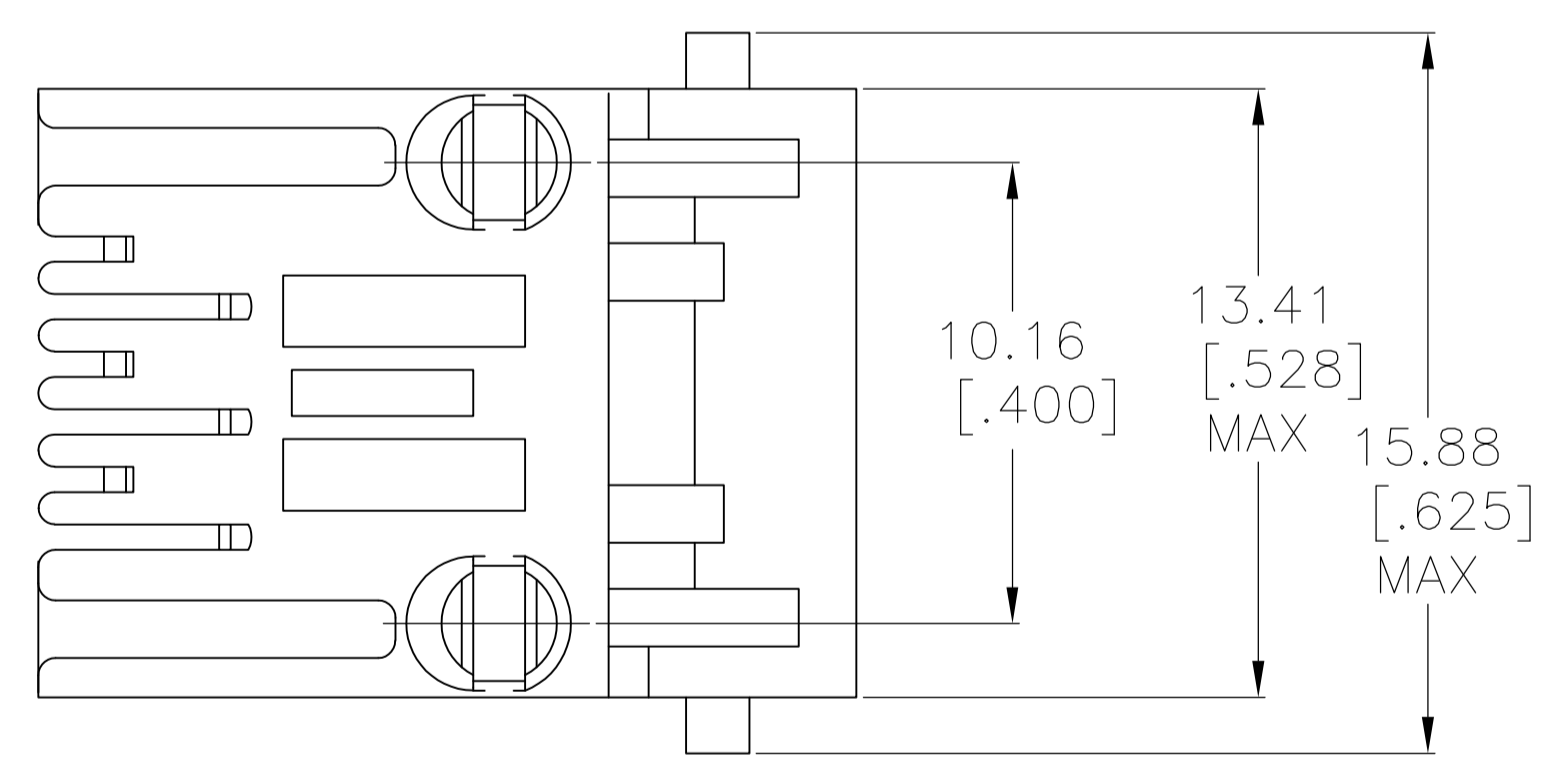

RECOMMENDED PRINTED CIRCUIT BOARD LAYOUT COMPONENT SIDE SHOWN

PACKAGE	TERMINALS REQUIRED	PART NUMBER
4	2	5555163-5
4	4	5555163-2
4	6	5555163-1

THIS DRAWING IS A CONTROLLED DOCUMENT.

DIMENSIONS: mm [INCHES]	TOLERANCES UNLESS OTHERWISE SPECIFIED:	DIN G. ATTADIA - 08/JUN/2005	DOBCKS 08/JUN/2005	APVD J. WESTMAN 08/JUN/2005	NAME S. FLICKINGER 08/JUN/2005	Tyco Electronics Corporation Harrisburg, PA 17105-3608
0 PLC ± -	1 PLC ± -	2 PLC ± 0.13[.005]	3 PLC ± -	4 PLC ± -	ANGLES ± -	PRODUCT SPEC 108-1163
MATERIAL SEE NOTE 1	FINISH SEE NOTE 1	WEIGHT -	SIZE A1	CAGE CODE 00779	DRAWING NO. 5555163	RESTRICTED TO -
CUSTOMER DRAWING			SCALE 6:1	SHEET 1 OF 1	REV B	