

THIS DRAWING IS UNPUBLISHED. RELEASED FOR PUBLICATION
 © COPYRIGHT - By - ALL RIGHTS RESERVED.

LOC		DIST		REVISIONS			
P	LTR	DESCRIPTION	DATE	DWN	APVD		
AA	00						
	D	ECR-11-017936	28OCT2011	JJ	MQW		

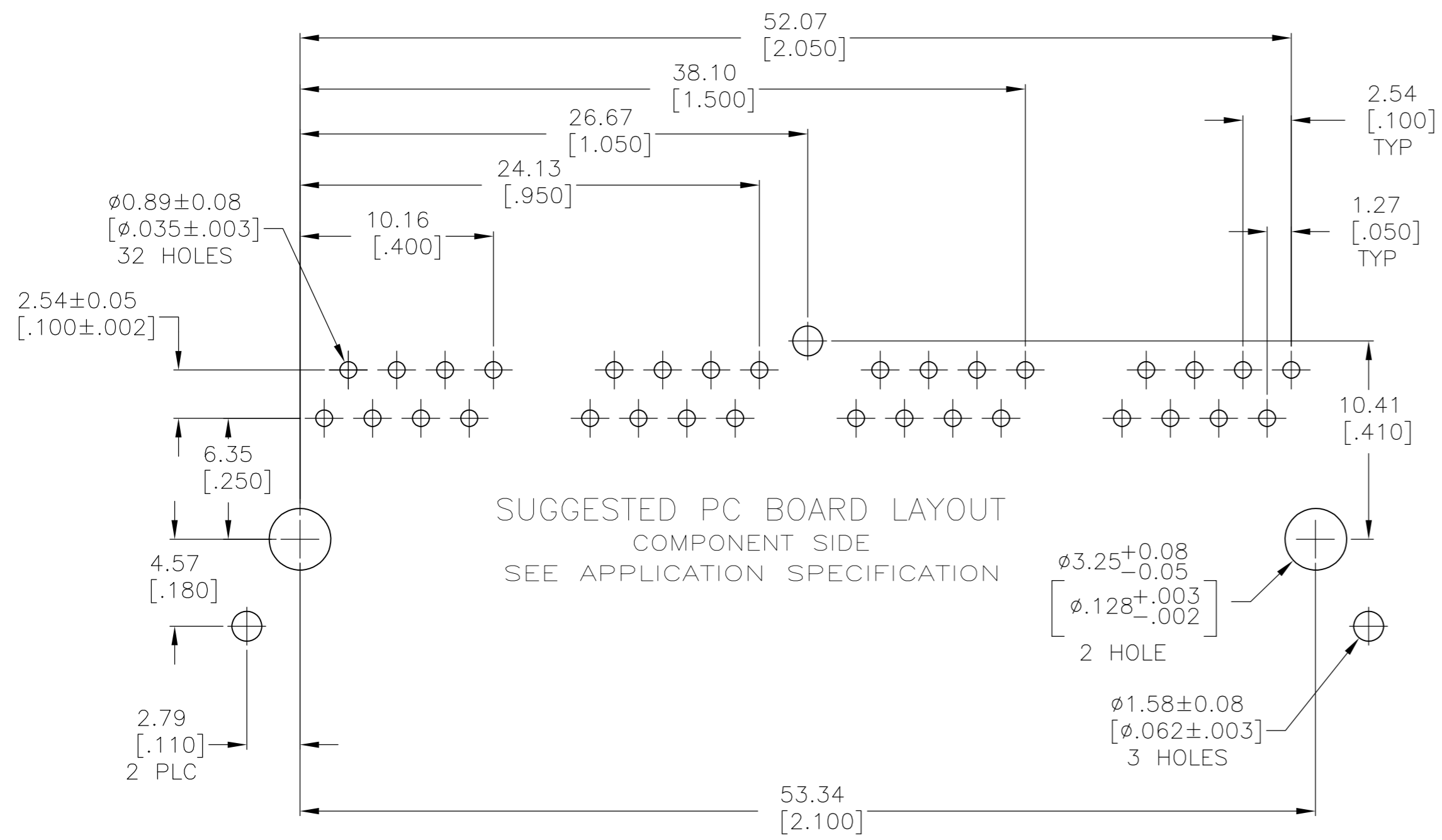
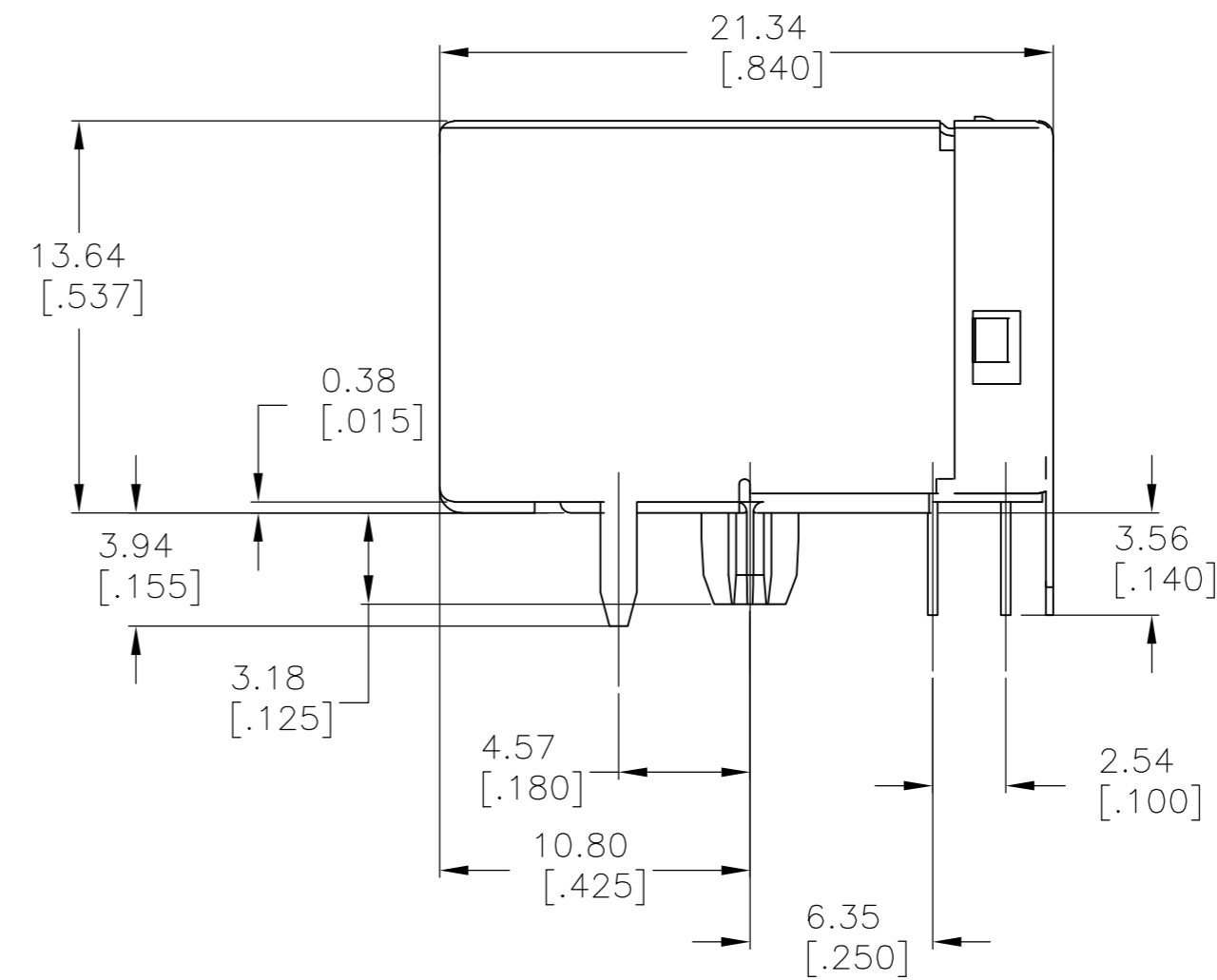
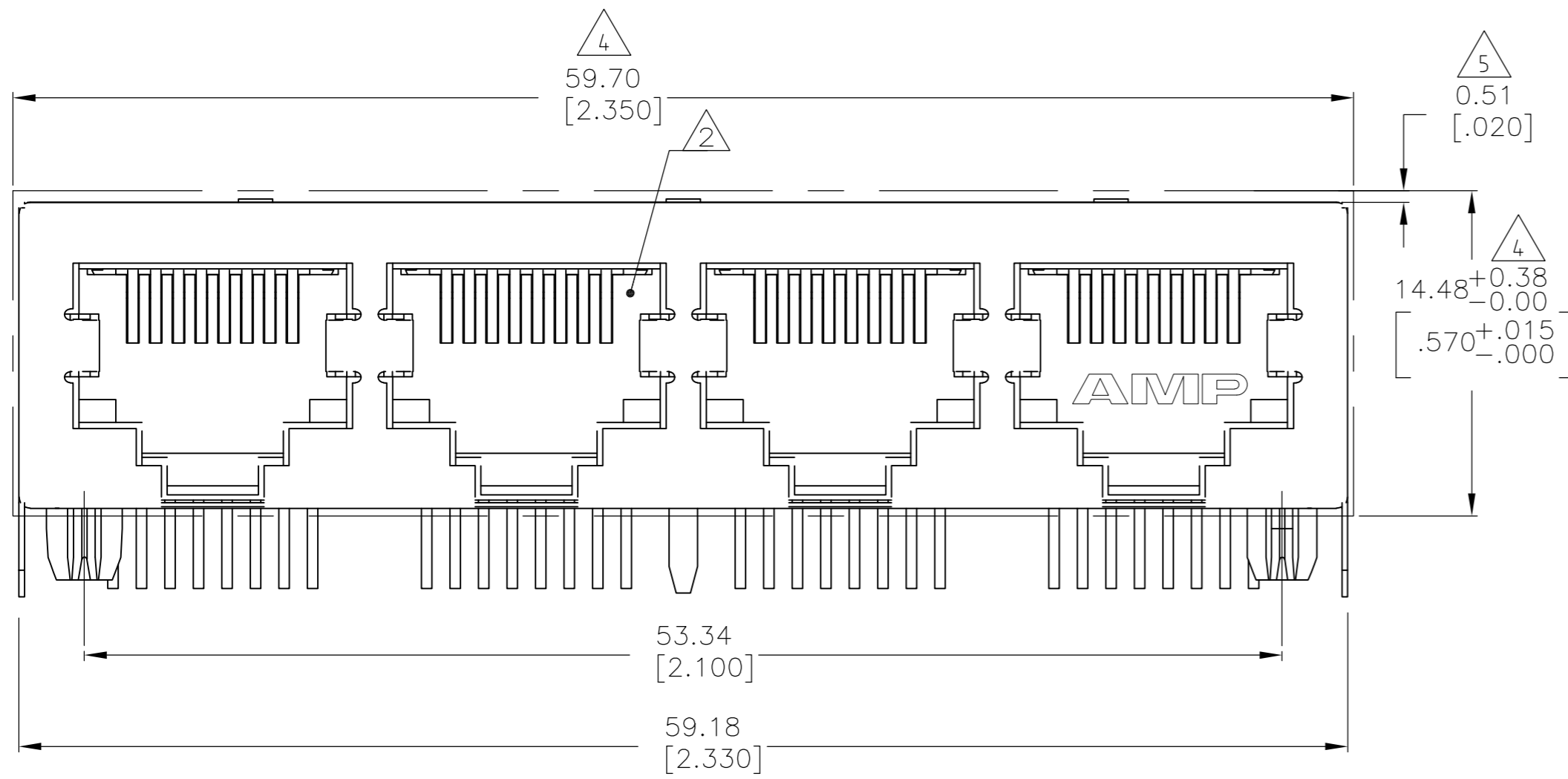

- MATERIAL: HOUSING- HIGH TEMPERATURE NYLON, BLACK, IR COMPATIBLE, UL 94V-0.
 TERMINALS - 0.33 [.013] THICK PHOS BRONZE PLATED WITH 1.27um [.000050] MINIMUM HARD GOLD IN LOCALIZED AREA AND 3.81um [.000150] MINIMUM TIN IN SOLDER AREA OVER 1.27um [.000050] MINIMUM NICKEL UNDERPLATE

SHIELDS - 0.25 [.010] THICK COPPER ALLOY PLATED WITH 1.27 um [.000050] MINIMUM NICKEL AND 2.03 um [.000080] MINIMUM HOT TIN DIP ON PCB GROUND TABS.

- JACK CAVITY CONFORMS TO FCC RULES AND REGULATIONS, PART 68 SUBPART F.
- CAUTION: CATEGORY 5 JACK SOLDER TAIL POSITIONS DO NOT FOLLOW SAME NUMBER SEQUENCE AS THAT OF THE TRADITIONAL JACKS.
- SUGGESTED PANEL OPENING DIMENSIONS
- SUGGESTED CLEARANCE BETWEEN TOP OF CONNECTOR AND TOP PANEL OPENING

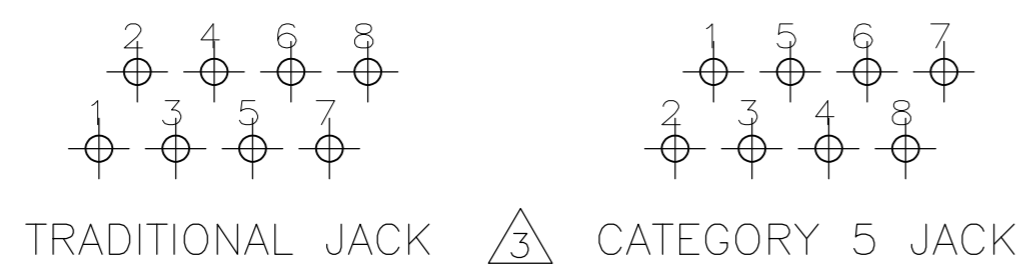

5558503-1
PART NUMBER

THIS DRAWING IS A CONTROLLED DOCUMENT.		DWN W. LONG/L.A.MAYER 04NOV2006	TE Connectivity	
DIMENSIONS: mm [INCHES]		CHK J.WESTMAN 04NOV2006	NAME	
TOLERANCES UNLESS OTHERWISE SPECIFIED:		APVD S.FLICKINGER 04NOV2006	PRODUCT SPEC	
0 PLC ± -		108-1163-2		
1 PLC ± -		APPLICATION SPEC		
2 PLC ± 0.25 [.010]		114-2048		
3 PLC ± -		WEIGHT		
4 PLC ± -		-		
ANGLES ± -		SIZE		
FINISH		A2		
SEE NOTE 1		CAGE CODE		
SEE NOTE 1		00779		
CUSTOMER DRAWING		DRAWING NO		
		C=5558503		
		RESTRICTED TO		
		-		
		SCALE		
		4:1		
		SHEET		
		1 of 1		
		REV		
		D		