

Distributed by:

JAMECO[®]
ELECTRONICS

www.Jameco.com ♦ 1-800-831-4242

The content and copyrights of the attached
material are the property of its owner.

Jameco Part Number 1405325

THIS DRAWING IS UNPUBLISHED. RELEASED FOR PUBLICATION
 © COPYRIGHT BY TYCO ELECTRONICS CORPORATION. ALL RIGHTS RESERVED.

LOC		DIST		REVISIONS			
P	LTR	DESCRIPTION		DATE	DWN	APVD	
GP	00	A		REVISED PER ECO-06-029348	21DEC06	JDP/SLB	

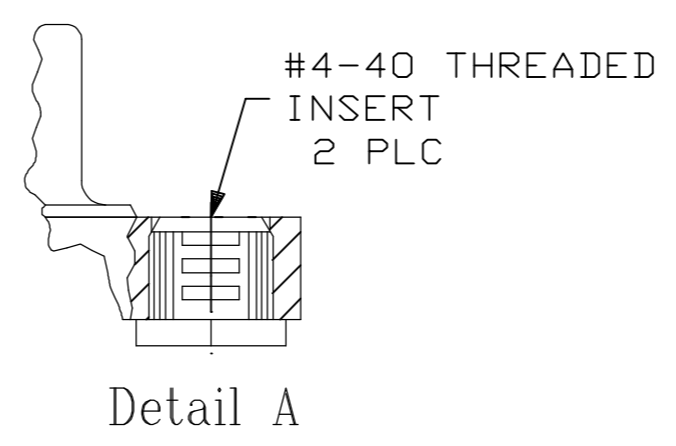
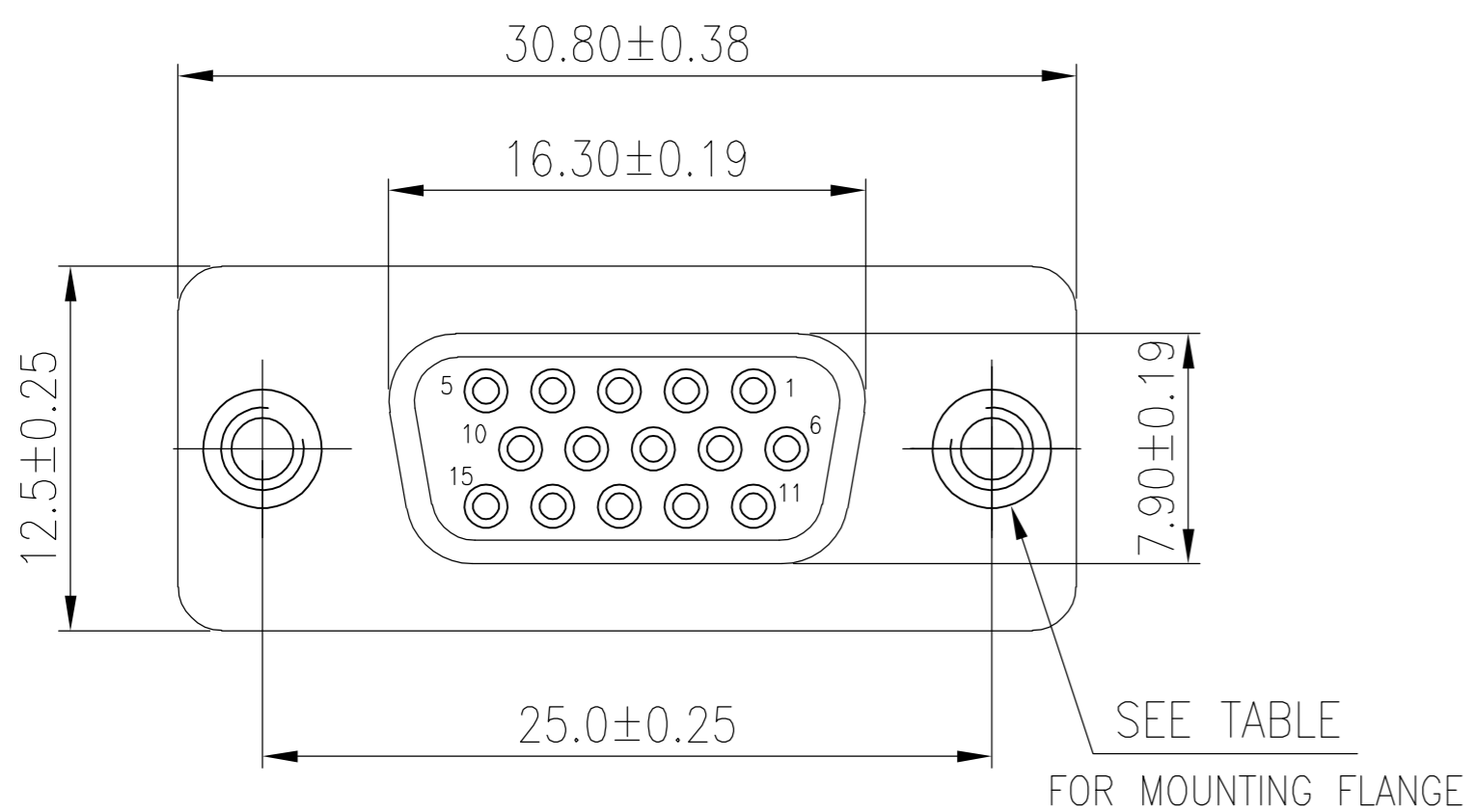

- HOUSING: PBT, 30% GF POLYESTER, UL 94V-0 RATED, COLOR BLACK.
 - CONTACTS: PHOSPHOR BRONZE, GOLD PLATE IN MATING AREA (SEE TABLE), 120µ" MIN TIN PLATE ON SOLDER TAIL, BOTH OVER 50µ" MIN NICKEL UNDERPLATE.
 - SHELL: STEEL, NICKEL PLATE.
 - THREADED INSERTS AND BOARDLOCKS: BRASS, 100µ" MIN TIN PLATE OVER 50µ" MIN NICKEL UNDERPLATE.
- △5 FOUR DIGIT DATE CODE IN THIS FORMAT.
 YEAR 01 45 MANUFACTURING WEEK
- △6 MAXIMUM SHAFT LENGTH OF SCREWLOCK TO ALLOW THE SCREWLOCK HEAD TO SIT FLAT ON S-SUB IS 4.70. RECOMMENDED TYCO SCREWLOCK IS 747877-3.

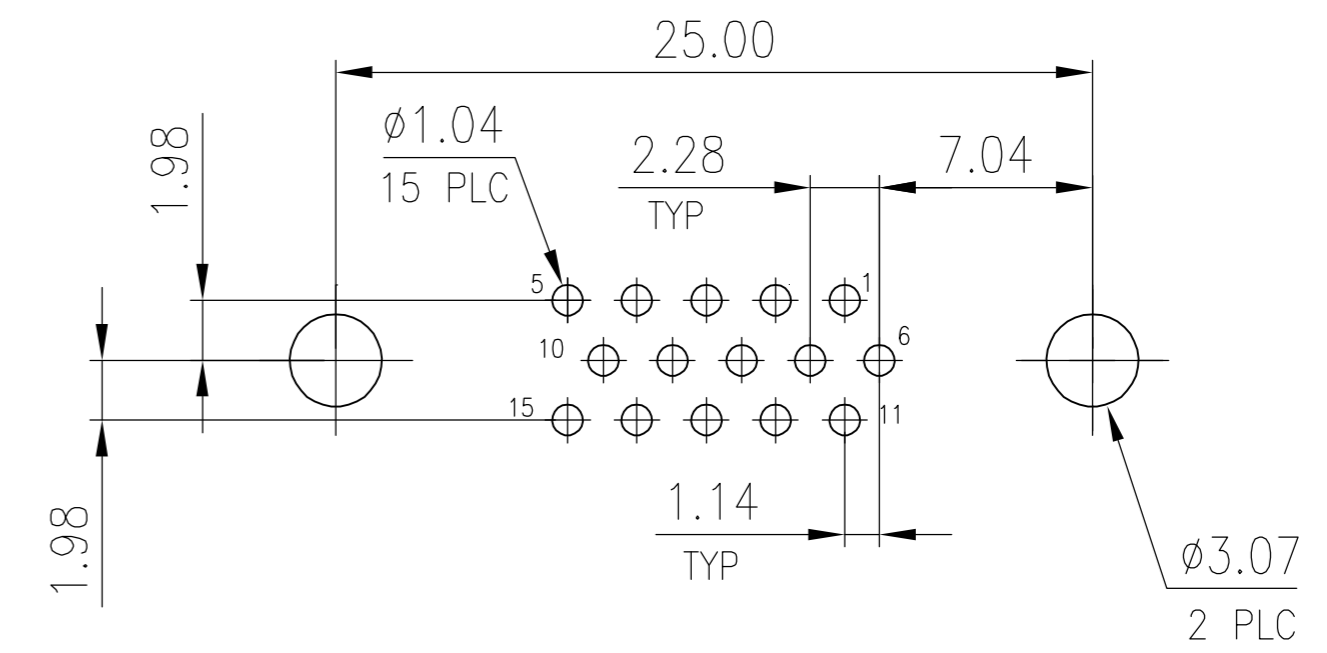
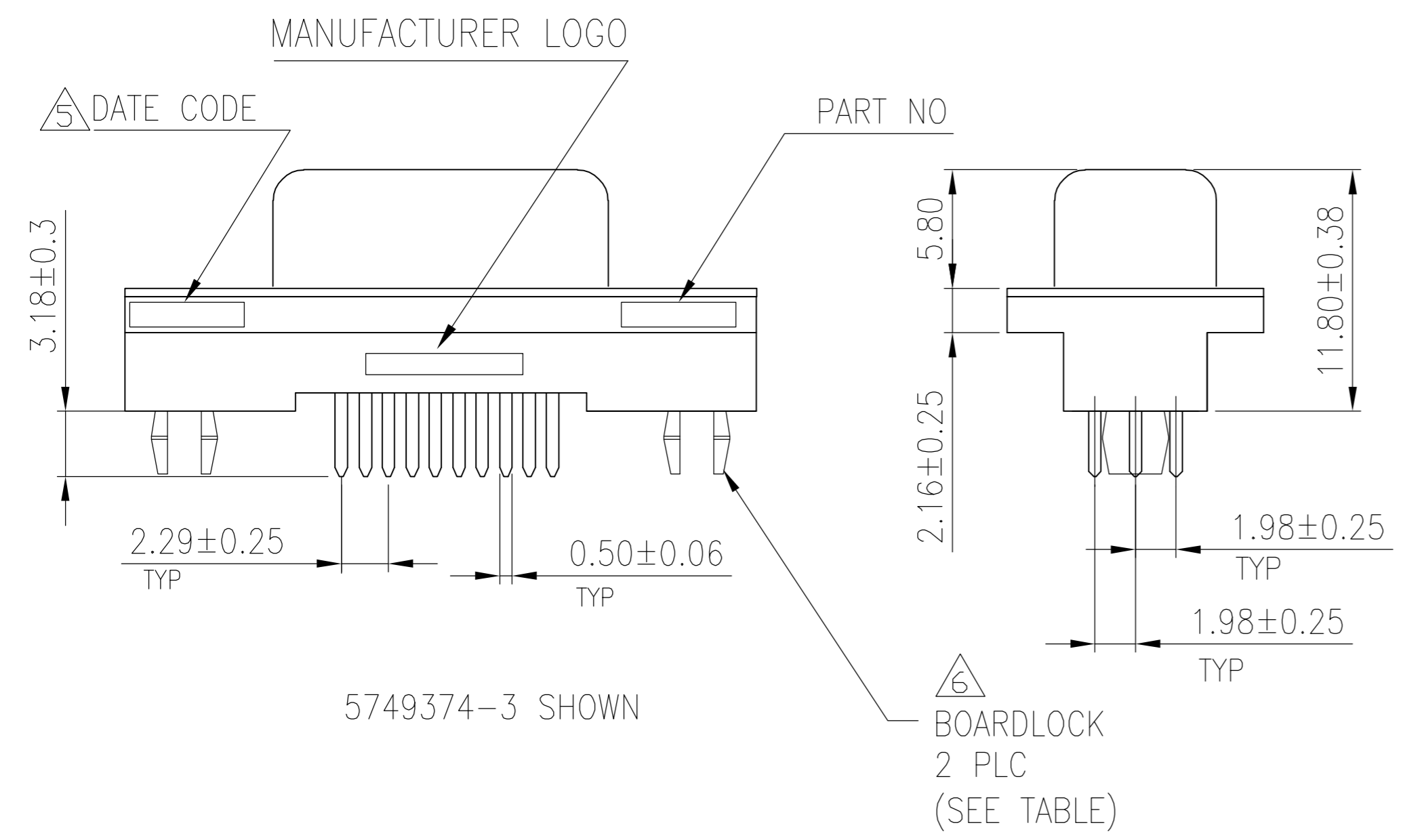

RECOMMENDED PCB LAYOUT

No	Tray	Detail A	15 µ" MIN GOLD	5749374-7
Yes	Tray	Detail A	30 µ" MIN GOLD	△6 5749374-3
No	Tray	Detail A	30 µ" MIN GOLD	5749374-1
BOARDLOCK	Packaging	Mounting Flange Config	Contact Mating Area Finish	Part No

5749374-3 SHOWN

△6 BOARDLOCK 2 PLC (SEE TABLE)

THIS DRAWING IS A CONTROLLED DOCUMENT.		DWN R.RICHARDSON 31MAY05	tyco Tyco Electronics Corporation Harrisburg, PA 17105-3608	
DIMENSIONS: mm		CHK S.BOLASH 31MAY05	NAME AMPLIMITE HD-22 15 POS RECEPTACLE, VERTICAL	
TOLERANCES UNLESS OTHERWISE SPECIFIED:		APVD M.WALMSLEY 31MAY05	SIZE A2 CAGE CODE 00779 DRAWING NO C=5749374 RESTRICTED TO	
0 PLC ± -		PRODUCT SPEC	SCALE 1:1 SHEET 1 of 1 REV A	
1 PLC ± 0.30		APPLICATION SPEC		
2 PLC ± 0.20		WEIGHT -		
3 PLC ± 0.10		CUSTOMER DRAWING		
4 PLC ± -				
ANGLES ± 2°				
FINISH -				