Connector, 0.8mm CHAMP*

1. SCOPE**1.1. Content**

This specification covers performance, tests and quality requirements for 0.8mm CHAMP* connectors. These connectors are cable mounted plug connectors and printed circuit board mounted plug and receptacle connectors.

1.2. Qualification

When tests are performed on subject product line, procedures specified in AMP 109 series specifications shall be used. All inspections shall be performed using applicable inspection plan and product drawing.

2. APPLICABLE DOCUMENTS

The following documents form a part of this specification to the extent specified herein. Unless otherwise specified, latest edition of the document applies. In the event of conflict between requirements of this specification and product drawing, product drawing shall take precedence. In the event of conflict between requirements of this specification and referenced documents, this specification shall take precedence.

2.1. AMP Documents

- A. 109-1: General Requirements for Test Specifications
- B. 109 Series: Test Specifications as indicated in Figure 1. (Comply with MIL-STD-202, MIL-STD-1344 and EIA RS-364)
- C. Corporate Bulletin 401-76: Cross-reference between AMP Test Specifications and Military or Commercial Documents
- D. 114-6057: Application Specification
- E. 501-335: Test Report

3. REQUIREMENTS**3.1. Design and Construction**

Product shall be of design, construction and physical dimensions specified on applicable product drawing.

3.2. Materials

- A. Cable connector backshell hardware:
 - (1) Jackscrews: Steel, clear chromate over zinc plating
 - (2) Spring latch: Stainless steel
- B. Contact:
 - (1) Cable connector: Phosphor bronze, selective gold plating in contact area, tin-lead plating on crimp area, all over nickel over palladium nickel plating
 - (2) PC board connector: Phosphor bronze, selective gold plating in contact area, tin-lead plating on solder tails, all over nickel over palladium nickel plating

- C. Housing:
 - (1) PC board connector: LCP, black, 240°C, UL94V-0
 - (2) Cable connector:
 - (a) Jackscrew overmold: ABS, black, 85°C, UL94V-0
 - (b) Plastic backshells: ABS, black, 85°C, UL94V-0
 - (c) Plug housing: LCP, black and natural, 240°C, UL94V-0
 - (d) Termination covers: ABS, black, 85°C, UL94V-0
- D. PCB connector boardlock: Brass, matte tin-lead over nickel plating
- E. Shell:
 - (1) Backshell: Steel, bright tin or tin-lead over copper plating
 - (2) Cable connector front: Steel, bright tin or tin-lead over copper plating
 - (3) PCB connector: Steel, nickel over copper plating

3.3. Ratings

- A. Voltage: 30 vac
- B. Current: 1.5 amperes single circuit; 0.5 ampere at 10°C temperature rise, maximum of 50% contacts energized; 0.3 ampere 100% energized. See Figure 2.
- C. Temperature: -55 to 85°C unless limited by temperature rating of cable

3.4. Performance and Test Description

Product is designed to meet electrical, mechanical and environmental performance requirements specified in Figure 1. Unless otherwise specified, all tests shall be performed at ambient environmental conditions per AMP Specification 109-1.

3.5. Test Requirements and Procedures Summary

Test Description	Requirement	Procedure
Examination of product.	Meets requirements of product drawing and AMP Spec 114-6057.	Visual, dimensional and functional per applicable quality inspection plan.
ELECTRICAL		
Termination resistance.	+ΔR 10 milliohms maximum.	AMP 109-6-1. Subject mated contacts assembled in housing to 50 mv maximum open circuit at 100 ma maximum. See Figure 3.
Insulation resistance.	500 megohms minimum.	AMP Spec 109-28-3. Test between adjacent contacts of mated but unmounted samples.
Dielectric withstanding voltage.	250 vac at sea level.	AMP Spec 109-29-1. Test between adjacent contacts of mated but unmounted samples.
MECHANICAL		
Solderability.	Solderable area shall have minimum of 95% solder coverage.	AMP Spec 109-11-1. Subject contacts to solderability.

Figure 1 (cont)

Test Description	Requirement	Procedure						
Vibration, random.	No discontinuities of 1 microsecond or longer duration. See Note.	AMP Spec 109-21-7. Subject mated samples to 4.41 G's rms between 5-500 Hz. 20 minutes in each of 3 mutually perpendicular planes. See Figure 4.						
Physical shock.	No discontinuities of 1 microsecond or longer duration. See Note.	AMP Spec 109-26-1, except 30 G's. Subject mated samples to 30 G's half-sine shock pulses of 11 milliseconds duration. 3 shocks in each direction applied along 3 mutually perpendicular planes, 18 total shocks. See Figure 4.						
Durability.	See Note.	AMP Spec 109-27. Mate and unmate samples for 2000 cycles at maximum rate of 500 cycles per hour.						
Mating force.	<table border="1" data-bbox="646 873 971 999"> <thead> <tr> <th>Connector Positions</th> <th>Newtons Maximum</th> </tr> </thead> <tbody> <tr> <td>90</td> <td>50</td> </tr> <tr> <td>68</td> <td>44</td> </tr> </tbody> </table>	Connector Positions	Newtons Maximum	90	50	68	44	AMP Spec 109-42, Condition A. Measure force necessary to mate samples with locking latches at maximum rate of 13mm per minute.
Connector Positions	Newtons Maximum							
90	50							
68	44							
Unmating force.	<table border="1" data-bbox="646 1083 971 1209"> <thead> <tr> <th>Connector Positions</th> <th>Newtons Minimum</th> </tr> </thead> <tbody> <tr> <td>90</td> <td>6</td> </tr> <tr> <td>68</td> <td>6.2</td> </tr> </tbody> </table>	Connector Positions	Newtons Minimum	90	6	68	6.2	AMP Spec 109-42, Condition A. Measure force necessary to unmate samples with locking latches removed or released at maximum rate of 13mm per minute.
Connector Positions	Newtons Minimum							
90	6							
68	6.2							
Housing lock strength.	125 Newtons kilograms minimum.	AMP Spec 109-50. Determine strength of housing locking mechanism at rate of 13mm per minute.						
ENVIRONMENTAL								
Thermal shock.	See Note.	AMP Spec 109-22. Subject mated samples to 5 cycles between -55 and 85°C.						
Humidity-temperature cycling.	See Note.	AMP Spec 109-23-3, Condition B. Subject mated samples to 10 cycles between 25 and 65°C at 95% RH.						

Figure 1 (cont)

Test Description	Requirement	Procedure
Temperature life.	See Note.	AMP Spec 109-43. Subject mated samples to temperature life at 85°C for 500 hours.
Mixed flowing gas.	See Note.	AMP Spec 109-85-2. Subject mated samples to environmental class II for 14 days.

NOTE *Shall meet visual requirements, show no physical damage and shall meet requirements of additional tests as specified in Test Sequence in Figure 3.*

Figure 1 (end)

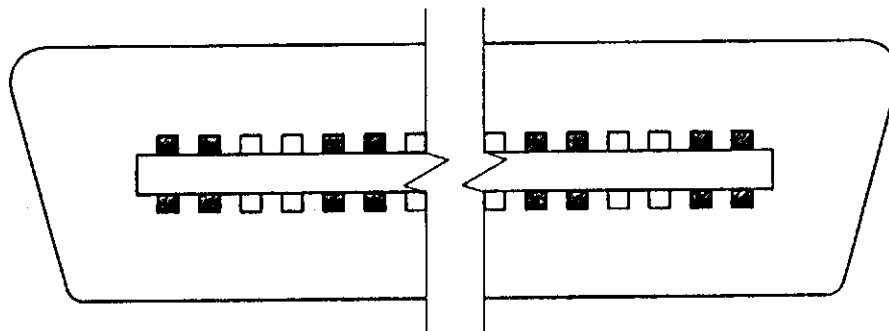

■ DENOTES ENERGIZED CIRCUIT

Figure 2
Current Energizing Circuit

3.6. Product Qualification and Requalification Test Sequence

Test or Examination	Test Group (a)				
	1	2	3	4	5
	Test Sequence (b)				
Examination of product	1,9	1,6	1,5	1,8	1,3
Termination resistance	3,7	2,4	2,4		
Insulation resistance				2,6	
Dielectric withstanding voltage				3,7	
Solderability					2
Vibration	5				
Physical shock	6				
Durability	4				
Mating force	2				
Unmating force	8				
Housing lock strength		5			
Thermal shock				4	
Humidity-temperature cycling				5	
Temperature life		3(c)			
Mixed flowing gas			3(c)		

- NOTE**
- (a) See Para 4.1.A.
 - (b) Numbers indicate sequence in which tests are performed.
 - (c) Precondition samples with 10 cycles durability.

Figure 2

4. QUALITY ASSURANCE PROVISIONS

4.1. Qualification Testing

A. Sample Selection

Samples shall be prepared in accordance with applicable Instruction Sheets and shall be selected at random from current production. Test groups 1, 2, and 3 shall each consist of 5 printed circuit board connectors and 5 cable connectors. Test group 4 shall consist of 5 printed circuit board connectors. 30 random contacts shall be selected and identified. Unless otherwise specified, these contacts shall be used for all measurements.

B. Test Sequence

Qualification inspection shall be verified by testing samples as specified in Figure 2.

4.2. Requalification Testing

If changes significantly affecting form, fit or function are made to product or manufacturing process, product assurance shall coordinate requalification testing, consisting of all or part of original testing sequence as determined by development/product, quality and reliability engineering.

4.3. Acceptance

Acceptance is based on verification that product meets requirements of Figure 1. Failures attributed to equipment, test setup or operator deficiencies shall not disqualify product. When product failure occurs, corrective action shall be taken and samples resubmitted for qualification. Testing to confirm corrective action is required before resubmittal.

4.4. Quality Conformance Inspection

Applicable AMP quality inspection plan will specify sampling acceptable quality level to be used. Dimensional and functional requirements shall be in accordance with applicable product drawing and this specification.

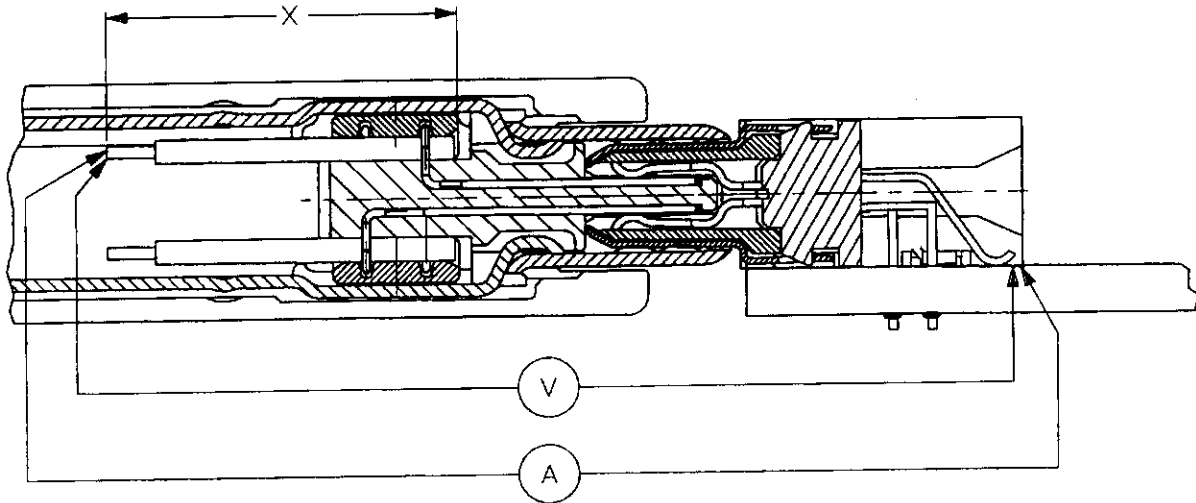

- VOLTAGE DROP DUE TO X mm OF WIRE IS TO BE REMOVED FROM ALL READINGS.
- BACKSHELLS AND COVERS SHOWN BROKEN FOR CLARITY.

CABLE TO BOARD

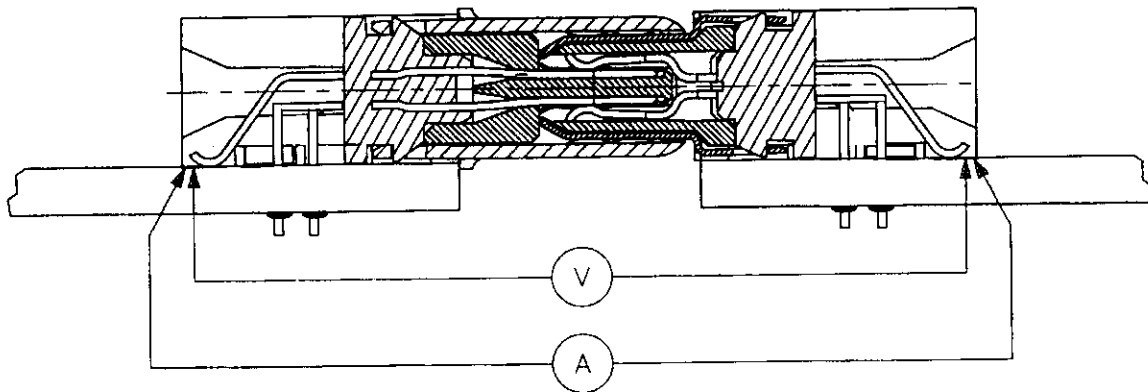

BOARD TO BOARD

Figure 4
Termination Resistance Measurement Points

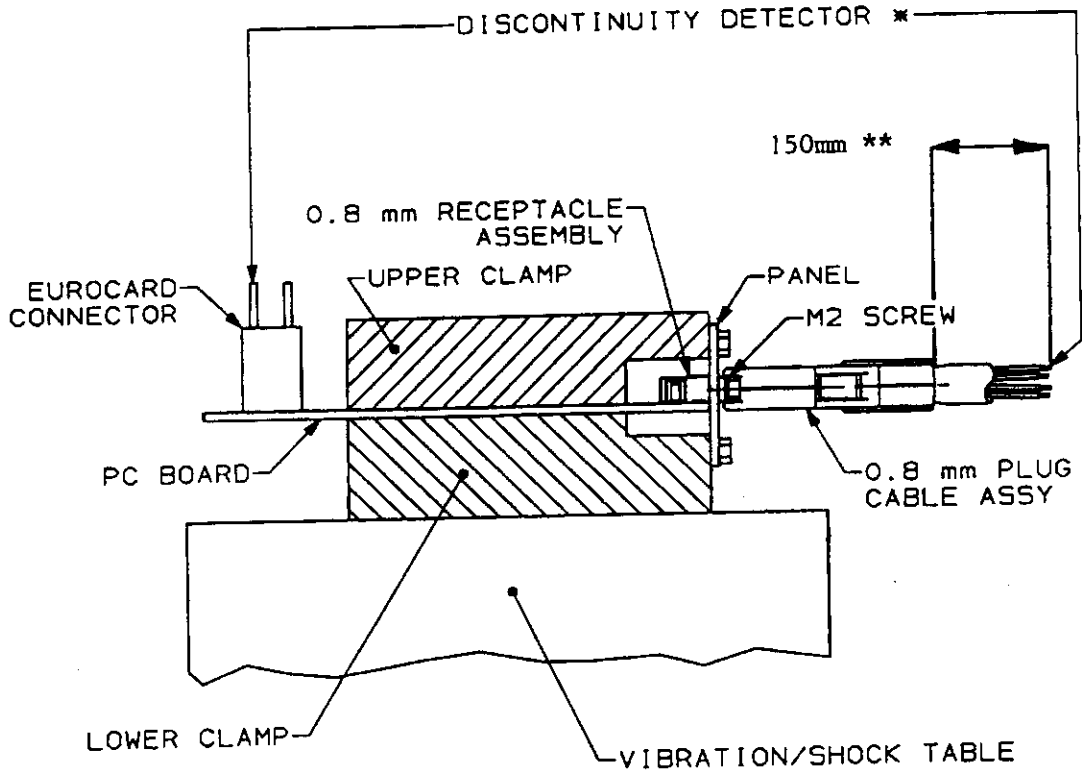

Note: * Samples may be series wired.
** Cable end clamped to vibrating member.

Figure 5
Vibration & Physical Shock Mounting Fixture